



# **DP-508D/DP-508D-L Stepper Drive**

**User Manual**

WUXI XINJE ELECTRIC CO., LTD.

NO. DC011 20131017 1.0



---

## Catalog

1. Summary .....	1
1-1. Characteristic .....	1
1-2. Application.....	1
1-3. Electric characters.....	1
2. Operation Guidance .....	2
2-1. Safety .....	2
2-2. Attention .....	2
2-3. Installation .....	2
3. Common Terminals .....	3
3-1. Control signal terminals.....	3
3-1-1. Description of Control signals terminals .....	3
3-1-2. Sequential chart of control signal .....	4
3-1-3. Input circuit .....	5
3-2. Power Terminals .....	5
3-2-1. Description of the terminal .....	5
3-2-2. Requirement of power supply.....	6
3-2-3. Wiring .....	6
3-3. Function Setting.....	7
3-3-1. Current Setting.....	7
3-3-2. Subdivision Setting.....	8
3-4. Function for Protection .....	8
4. Dimension installation and wiring .....	9
4-1. Dimension.....	9
4-2. Installation .....	9
4-3. Typical Wiring .....	10
5. Malfunction Diagnoses and Solution .....	11
6. Motor Selection.....	12



---

# 1. Summary

DP-508D/DP-508D-L subdivision stepper driver max input voltage is 80VDC, output current is 5.0A. The stepper drive is fit for 86 series two- phase hybrid stepper motor whose rated current is below 5.0 A. Based on the pure sine wave current control technology, this series product have a good performance in smoothly running with low noise, meets the high resolution requirement of the numerical control equipments, such as laser marking machine, CNC machine etc.

## 1-1. Characteristic

- Low noise on motor running.
- Power supply 80VDC.
- Effective value of output current can up to 5.0A.
- Dynamic selection on subdivision with maximal value of 200.
- Fit for 86 series two phases stepper motor whose current is below 5.0 A.
- Photo isolator input signal.
- Easy-operation on current setting and selection by user.
- Over-voltage and over-current protection.

## 1-2. Application

This series product can well meet the requirement of the small and medium automation devices and instruments, such as aerodynamic marking machine, labeling machine, cutting machine, laser marking machine, plotter, small carving machine, CNC machine etc., especially having a perfect performance on the devices which require low noise and vibration, high precision and speed.

## 1-3. Electric characters

Item	Min. value	Typical value	Max. value
Effective value of output current	0	-	5
Power supply voltage (VDC)	35	48	80
Logic input current (mA)	4	7	16
Stepper pulse frequency (KHz)	0	-	200
Insulation resistance(MΩ)	500	-	-
Ambient temperature	0°C~50°C		
Max working temperature	60°C		
Humidity	40%~90% RH (no condensation)		

---

Vibration	5.9m/s <sup>2</sup> Max
Storage temperature	-20°C~65°C
Dimension	138mm×85mm×38mm

## 2. Operation Guidance

Please read the following suggestion carefully before you install the driver.

### 2-1. Safety

- The driver is authorized to be installed and operated by the professionals and technicians.
- Don't turn on the power before you connect the motor.
- Make sure that the driver input meets the technical requirements.
- Don't make the setting or measure operations on the motor and driver during power on.
- Please do the wiring, installation and parameter setting after power is off for more than 3 minutes.
- Ensure the connection operation is absolutely correct and fixable before you turn on the power, including the power wire, motor cable and signal cable.
- Avoid electromagnetic interference.

### 2-2. Attention

- Please use shield cable for signal input, and leave each other for distance. The further the distance, the better the interference is avoided.
- Please connect the motor cover to the GND terminal.
- Don't operate on the output terminal when power on, or else the driver will be damaged.

### 2-3. Installation

- Don't install the driver next to the heat producing appliance.
- Don't exposure the driver to the dusty, corrosive gas, elevated humidity, and advised to use with small vibration.
- For perfect conducting, please ensure the fixation between earth wire of host computer, driver, motor and ground. The connecting ground resistor is less than 2  $\Omega$ .

### 3. Common Terminals

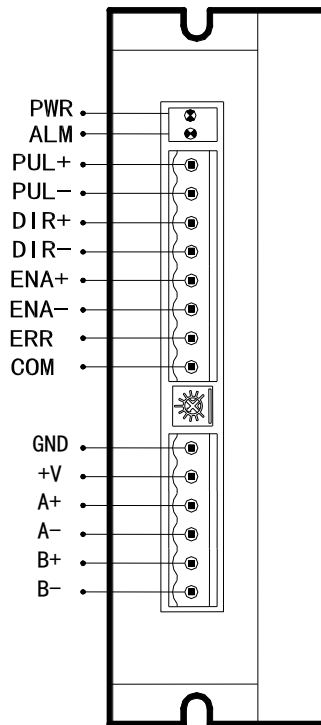

#### 3-1. Control signal terminals

##### 3-1-1. Description of Control signals terminals

Signal	Function	Description
PUL+	Pulse control signals	Be available on the rising edge, motor moves a step at the rising edge of pulse turning from low- level to high-level. PUL high voltage is 24V (DP-508D-L is 5V), low voltage is 0~0.5V.
PUL-		
DIR+	Direction control signals	The direction of motor rotating changed by the switching of pulse between low-level and high-level .Once the pulse status is changed, the direction correspondingly turns. The original direction depends on the wiring of motor, which means the phase connection. High voltage is 24V (DP-508D-L is 5V), low voltage is 0~0.5V.
DIR-		
ENA+	Enable/release signal	Used for motor release. The stepper will not be active when ENA+ terminal connects to 24V (DP-508D-L is 5V) and ENA- connects to

ENA-		low-level, in this case, the driver cuts off current of all phases and in free status, and also the temperature decrease. Please hang these terminals in the air if do not use them.
ERR	Error signal	The error signal is output from the ERRO and COM terminal when over-voltage or under-voltage.
COM	output	

### 3-1-2. Sequential chart of control signal

In order to ensure the reliability of the system response, please take the following advices.

- The high-level signal is effective when voltage is 24V (DP-508D-L is 5V); the low-level signal is effective when in the range of 0V to 0.5V.
- The ENA (enable) signal should be turned to low-level 3s before DIR (direction) signal or more.
- Ensure the falling edge of the DIR (direction) signal built 5 $\mu$ s before PUL (pulse) signal or more.
- The width of pulse should be more than 1.2 $\mu$ s
- The duration of the low-level pulse should be more than 1.2 $\mu$ s

The sequential chart shows as below:

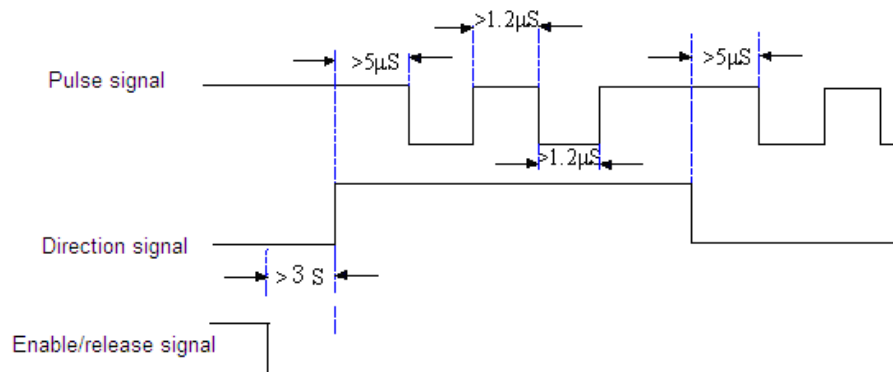



### 3-1-3. Input circuit

The connection on common anode way of the drive input circuit is shown as below:

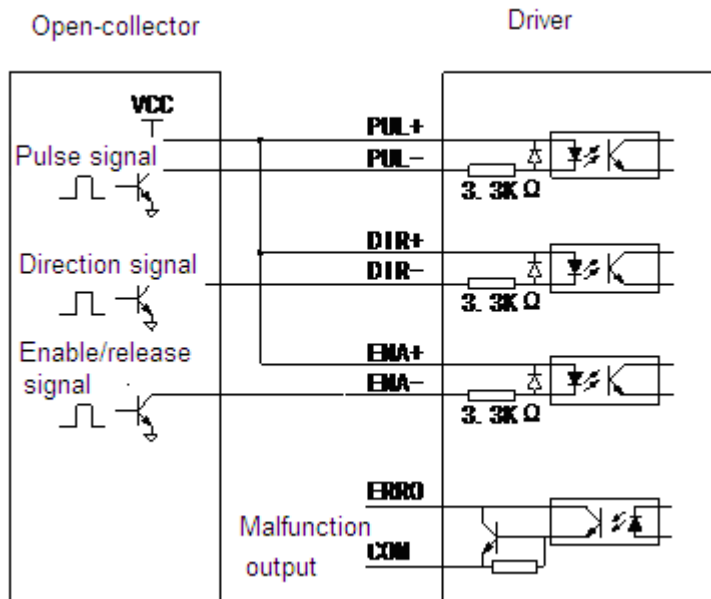

**Note:**

- The input signal is photoelectric isolation. Make sure the control signal driven current is more than 8mA to keep the good conducting of the internal high-speed light-coupler.
- Light-coupler current limiting resistor is built in stepper driver. It is common to supply all the control signals with +24V (DP-508D-L is 5V).

## 3-2. Power Terminals

### 3-2-1. Description of the terminal

Terminal	Function	Description
GND	DC power supply ground terminal	DC power supply ground terminal
+V	Positive terminal of DC power supply	the value is between min voltage and max voltage, it is better to use recommended value
A+, A-	A-phase of motor	Switching the A+ and A- can change the motor direction
B+, B-	B-phase of motor	Switching the B+ and B- can change the motor direction

---

### 3-2-2. Requirement of power supply

- Don't connect the power supply terminal in reverse way.
- To keep the normal working of drive, please ensure the power supply in this range: 35~80VDC.
- It is better to use non-regulated DC power supply, and make sure the current output of power is 60% higher than setting current of driver.
- Please ensure the current of power supply is higher than motor working current.

### 3-2-3. Wiring

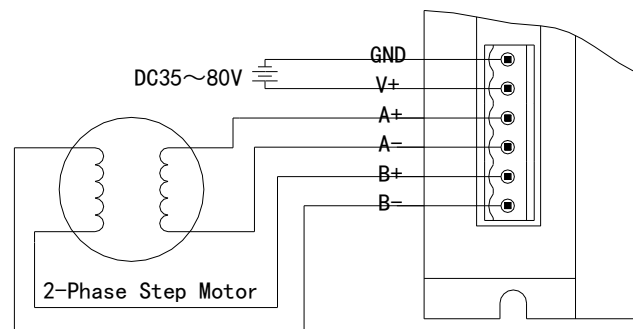

#### Note:

The motor performance depends on the connection between driver and motor. In most situation, the high-speed performance of motor is based on the power supply (the greater the power supply voltage, the greater the high-speed torque, and avoid step missing), and the output torque is based on the setting current (the greater the setting current, the greater the output torque of motor).

However, please pay attention that the motor is getting heat when the setting current is large, and the vibration of low-speed running is serious when the power supply voltage is large. Above all, please do the connection according to the requirement all the time.

There are some typical connections for your reference as below:

- Parallel connection mode with 8-lines: the setting current value is 1.4 times than motor rated current.
- Serial connection mode with 8-lines: the setting current value is 70% of the motor rated current.
- High-speed mode with 4/6 lines: the setting current value should be equal to or lower than the motor rated current.
- High-torque mode with 6 lines: the setting current value is 70% of the motor rated current.

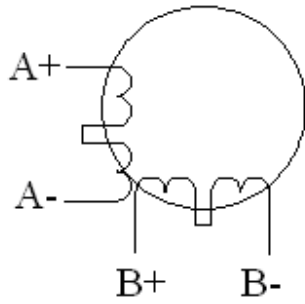

Serial-connection with 8-leads  
large torque at a low speed

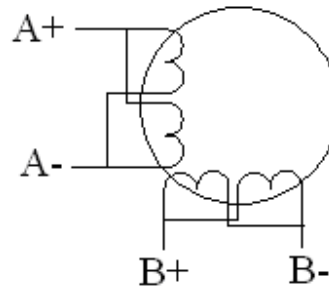

Parallel connection with 8-leads  
good performance at a high speed

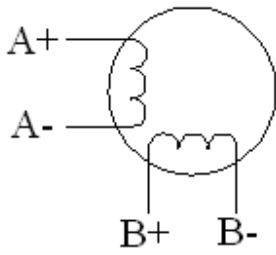

Motor with 4 leads

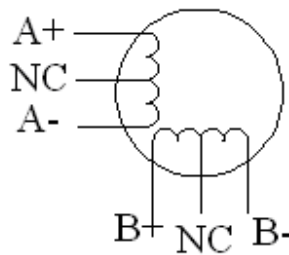

6-leads motor with large torque

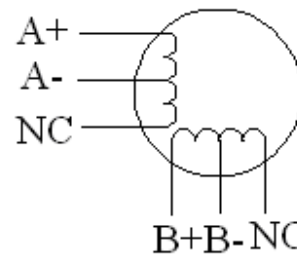

6-leads motor with high speed

### 3-3. Function Setting

The setting of the full-current/half-current and subdivision precision is based on the status of 5-bits switch. The details are shown as below:

SW1: Set half-current/full-current (SW1=OFF; half-current; SW1=ON; full-current)

SW2~SW5: Set the precision of subdivision.

#### 3-3-1. Current Setting

Set the current in the range of (0~5.0A) by single-turn potentiometer as below:

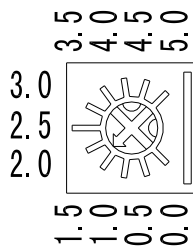

---

### 3-3-2. Subdivision Setting

The precision of the subdivision is based on the status of 4-bits switch, as below:

Subdivision multiple	Steps/turn (1.8 %step)	SW2	SW3	SW4	SW5
1	200	OFF	OFF	OFF	OFF
2	400	OFF	OFF	OFF	ON
4	800	OFF	OFF	ON	OFF
8	1600	OFF	OFF	ON	ON
16	3200	OFF	ON	OFF	OFF
32	6400	OFF	ON	OFF	ON
64	12800	OFF	ON	ON	OFF
128	25600	OFF	ON	ON	ON
5	1000	ON	OFF	OFF	OFF
10	2000	ON	OFF	OFF	ON
20	4000	ON	OFF	ON	OFF
25	5000	ON	OFF	ON	ON
40	8000	ON	ON	OFF	OFF
50	10000	ON	ON	OFF	ON
100	20000	ON	ON	ON	OFF
200	40000	ON	ON	ON	ON

### 3-4. Function for Protection

#### ■ Indicator LED

Power indicator light PWR: Green-light turning on means normal working.

Alarm indicator light ALM: It will alarm when red-light turns on which means over-voltage or over-current; the red-light flashing means over-voltage alarm, the red-light turning on constantly means over-current or short circuit alarm.

#### ■ Error output

The error signal output from the ERRO and COM terminal when there is over-voltage, over-current or short circuit alarm.

#### ■ Over-current/over-voltage/short circuit protection

If the power voltage is more than up-limit value (95V) or the current of motor is 20% higher than the setting value, or the motor phase wire is short circuit, the protection circuit will cut off the PWM output and the alarm indicator light turns on.

**Note:** the drive stops working when the protection circuit is active. After you remove the malfunction and restart the driver, the driver working normally again.

## 4. Dimension installation and wiring

### 4-1. Dimension

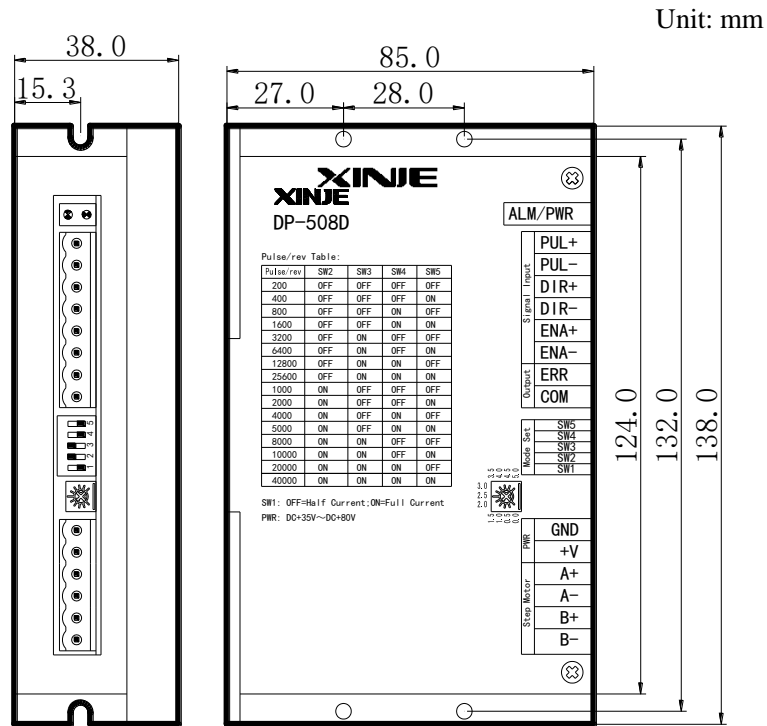

### 4-2. Installation

Install the driver in the well-ventilated cubicle under well protection and check the cooling fans periodically. Please leave at least 10cm around driver for cooling purpose. Avoid dust and moisture.

### 4-3. Typical Wiring

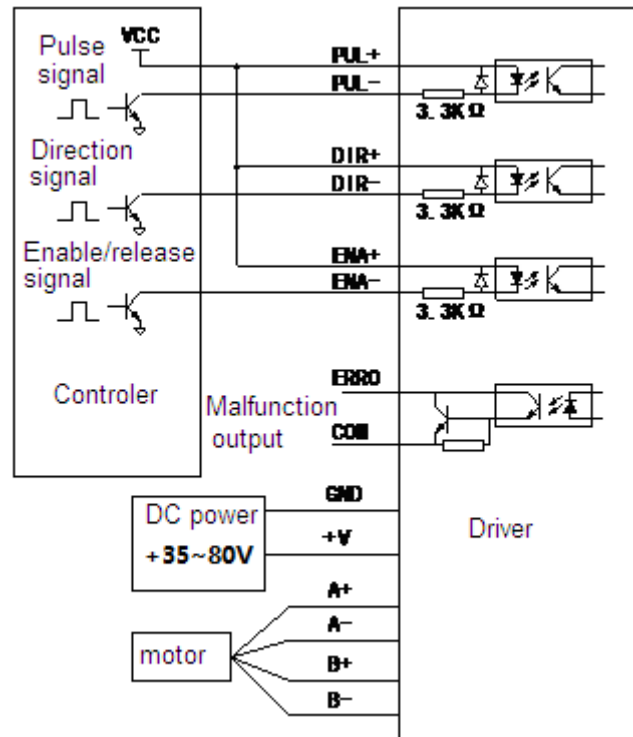

**Note:** please separate the power cables (power supply cable, phase cable) and the weak electricity cable in order to avoid interfering.

## 5. Malfunction Diagnoses and Solution

<b>Malfunction</b>	<b>Causation</b>	<b>Solution</b>
The power light doesn't work	Something wrong with the power supply	Check the power supply
	The voltage of power is not enough	Increase the voltage of power
The motor doesn't work	Current is too low	Reset the current
	Subdivision is too low	Reset the subdivision
	Protection circuit is active	Restart the driver
	The release signal is low	Remove this signal
	Power off	Restart the driver
	Connection on motor is incorrect	Check connection
	No pulse input	Adjust the pulse width and voltage
The direction of motor is incorrect	Inverse of phase-sequence	Exchange for phase-sequence
	Disconnection	Check connection
Alarm indicator turn on	Incorrect connection on motor	Rewire
	Over-voltage or too slow	Adjust the power voltage
	Motor or drive is damaged	Check the driver and motor
The torque of motor is too small	Acceleration is too high	Reduce the pulse acceleration
	Driver doesn't match with motor	Change a suitable driver

---

## 6. Motor Selection

The DP-508D, DP-508D-L is suitable for 86 series two phases mixed-type stepper motor.

Please pay attention to the torque and rated current when choosing a motor. The torque of motor is based on the dimension, the bigger the dimension, the greater the torque. And the current is based on the inductance, the smaller the inductance, the greater the current, and the better the performance of motor at high speed.

But when the motor is used with some special connections, the greater the current, the greater the output torque, the motor is getting hot. And the higher the power supply voltage, the greater the high-speed torque. The torque at high-speed is smaller than the one at low-speed.



**XINJE**

**WUXI XINJE ELECTRIC CO., LTD.**

4th Floor, Building 7th, No.100 Dicui Rd,  
Wuxi, China

Tel: 86-0510-85134139

Fax: 86-0510-85111290

[www.xinje.com](http://www.xinje.com)

Email: [fiona.xinje@vip.163.com](mailto:fiona.xinje@vip.163.com)