



# **VH5 series frequency convertor**

## **User manual**

Wuxi XINJE Electric Co., Ltd.

Data No. INV C 06 20210720 1.2

## **Basic description**

- ◆ Thank you for purchasing Xinje VH5 series frequency converter. Please read this product manual carefully before carrying out relevant operation.
- ◆ The manual mainly provides users with relevant guidance and instructions for the correct use and maintenance of the frequency converter. The manual involves the functions of the frequency converter capability, usage, installation and maintenance, etc.
- ◆ The contents in the manual are only applicable to the inverter products of Xinje company.

## **Notice to users**

This manual is applicable to the following personnel:

- ◆ The installation personnel of frequency converter
- ◆ Engineering and technical personnel (electrical engineer, electrical operator, etc.)
- ◆ The designer

Before the above personnel operate or debug the inverter, please carefully read the chapter of safety precautions in this manual.

## **Statement of responsibility**

- ◆ Although the contents of the manual have been carefully checked, errors are inevitable, and we can not guarantee the complete consistency.
- ◆ We will check the contents of the manual frequently and make corrections in subsequent versions. We welcome your valuable comments.
- ◆ The contents described in the manual are subject to change without prior notice.

## **Contact us**

If you have any questions about the use of this product, please contact the agent that purchased the product, or you can contact Xinje company directly.

- ◆ Tel: 400-885-0136
- ◆ Fax: 0510-85111290
- ◆ Address: 4th floor, building 7, creative industry park, 100 DiCui Road, Wuxi City, China
- ◆ Post code: 214072
- ◆ Website: [www.xinje.com](http://www.xinje.com)

---

# Catalog

<b>1. PRODUCT INTRODUCTION</b> .....	<b>5</b>
<b>1-1. PRODUCT OVERVIEW</b> .....	<b>5</b>
<i>1-1-1. Naming rule</i> .....	<i>5</i>
<b>1-2. SPECIFICATION</b> .....	<b>5</b>
<i>1-2-1. Technical specification</i> .....	<i>5</i>
<i>1-2-2. General specification</i> .....	<i>6</i>
<b>2. INSTALLATION AND WIRING</b> .....	<b>8</b>
<b>2-1. INSTALLATION ENVIRONMENT</b> .....	<b>8</b>
<i>2-1-1. Environment requirements</i> .....	<i>8</i>
<i>2-1-2. Installation space and direction</i> .....	<i>8</i>
<i>2-1-3. Single installation</i> .....	<i>9</i>
<i>2-1-4. Multiple installation</i> .....	<i>9</i>
<i>2-1-5. Vertical installation</i> .....	<i>10</i>
<i>2-1-6. Extend the operate panel</i> .....	<i>10</i>
<b>2-2. WIRING NOTICE</b> .....	<b>12</b>
<b>2-3. MAIN CIRCUIT WIRING</b> .....	<b>12</b>
<i>2-3-1. Wiring diagram</i> .....	<i>12</i>
<i>2-3-2. Arrangement and description of main circuit terminals</i> .....	<i>13</i>
<i>2-3-3. Wiring process of main circuit</i> .....	<i>14</i>
<b>2-4. CONFIGURATION AND WIRING OF THE CONTROL CIRCUIT</b> .....	<b>15</b>
<i>2-4-1. Control circuit terminals</i> .....	<i>15</i>
<i>2-4-2. Analog I/O wiring</i> .....	<i>16</i>
<i>2-4-3. Digital I/O wiring</i> .....	<i>17</i>
<b>3. OPERATION AND APPLICATION</b> .....	<b>20</b>
<b>3-1. OPERATION PANEL</b> .....	<b>20</b>
<i>3-1-1. Appearance</i> .....	<i>20</i>
<i>3-1-2. Keyboard</i> .....	<i>20</i>
<i>3-1-3. LED lights</i> .....	<i>20</i>
<i>3-1-4. Operation method</i> .....	<i>21</i>
<i>3-1-5. Multi-function buttons</i> .....	<i>23</i>
<i>3-1-6. Quick reference of parameters</i> .....	<i>23</i>
<b>3-2. POWER ON</b> .....	<b>25</b>
<i>3-2-1. Inspection after power on</i> .....	<i>25</i>
<i>3-2-2. Initial power on operation</i> .....	<i>25</i>
<i>3-2-3. Start to debug</i> .....	<i>27</i>
<i>3-2-4. Debugging process</i> .....	<i>28</i>
<b>3-3. START STOP OF THE VFD</b> .....	<b>28</b>
<i>3-3-1. Start stop signal</i> .....	<i>28</i>
<i>3-3-2. Start mode</i> .....	<i>29</i>
<i>3-3-3. Stop mode</i> .....	<i>31</i>
<b>3-4. VFD OPERATION FREQUENCY</b> .....	<b>32</b>
<b>3-5. SWING FREQUENCY FUNCTION</b> .....	<b>32</b>

<b>3-6. MOTOR PARAMETERS AND TUNING .....</b>	<b>34</b>
3-6-1. <i>Motor parameter setting</i> .....	34
3-6-2. <i>Motor tuning</i> .....	34
<b>3-7. USING METHOD OF TERMINAL X .....</b>	<b>35</b>
<b>3-10. USING METHOD OF TERMINAL Y .....</b>	<b>35</b>
<b>3-9. USING METHOD OF TERMINAL AI .....</b>	<b>36</b>
<b>3-10. USING METHOD OF TERMINAL AO .....</b>	<b>36</b>
<b>4. FUNCTION PARAMETERS .....</b>	<b>37</b>
<b>4-1. FUNCTION CODE LIST .....</b>	<b>37</b>
<b>4-2. PARAMETER EXPLANATION .....</b>	<b>67</b>
4-2-1. <i>Group P0 basic operation parameter</i> .....	67
4-2-2. <i>Group P1 first motor parameters</i> .....	72
4-2-3. <i>Group P2 input terminal multi-function parameters</i> .....	73
4-2-4. <i>Group P3 output terminal multi-function parameters</i> .....	82
4-2-5. <i>Group P4 startup brake parameters</i> .....	86
4-2-6. <i>Group P5 VF parameters</i> .....	89
4-2-7. <i>Group P6 vector parameters</i> .....	95
4-2-8. <i>Group P7 fault and protection</i> .....	96
4-2-9. <i>Group P8 keyboard and display</i> .....	102
4-2-10. <i>Group P9 communication protocol</i> .....	105
4-2-11. <i>Group PA PID parameters of process control</i> .....	106
4-2-12. <i>Group PB multi-speed and simple PLC</i> .....	111
4-2-13. <i>Group PC auxiliary function</i> .....	113
4-2-14. <i>Group PE user optional parameters</i> .....	122
4-2-15. <i>Group PF torque control</i> .....	123
4-2-16. <i>Group A0 fixed length, counting and swing frequency</i> .....	124
4-2-17. <i>Group A1 virtual IO</i> .....	125
4-2-18. <i>Group A2 second motor parameters</i> .....	127
4-2-19. <i>Group AD AIAO correction parameters</i> .....	129
4-2-20. <i>Group U0 monitor parameters</i> .....	130
<b>5. EMC .....</b>	<b>132</b>
<b>5-1. EMC COMPLIANT INSTALLATION GUIDELINES .....</b>	<b>132</b>
5-1-1. <i>Noise suppression</i> .....	132
5-1-2. <i>Field wiring and grounding</i> .....	133
<b>6. MODEL AND DIMENSION .....</b>	<b>134</b>
<b>6-1. VH5 SERIES VFD ELECTRICAL SPECIFICATION .....</b>	<b>134</b>
<b>6-2. VH5 SERIES VFD DIMENSION .....</b>	<b>134</b>
<b>6-3. ACCESSORIES SELECTION GUIDE .....</b>	<b>135</b>
6-3-1. <i>Accessories functions</i> .....	135
6-3-2. <i>Cable selection</i> .....	136
6-3-3. <i>Selection guidance of circuit breaker, contactor and fuse</i> .....	138
6-3-4. <i>Reactor selection guide</i> .....	139
6-3-5. <i>Brake resistor selection</i> .....	139
<b>7. FAULT AND SOLUTION .....</b>	<b>142</b>

<b>7-1. FAULT ALARM AND SOLUTION</b> .....	142
<b>7-2. FAULT RECORD QUERY</b> .....	145
<b>7-3. FAULT RESET</b> .....	145
<b>7-4. VFD COMMON FAULT ANALYSIS OF FREQUENCY CONVERTER</b> .....	146
<b>7-4-1. Motor not rotate</b> .....	146
<b>7-4-2. Motor vibration</b> .....	147
<b>7-4-3. Over voltage</b> .....	147
<b>7-4-4. Motor overheat</b> .....	148
<b>7-4-5. Over current</b> .....	149
<b>7-4-6. VFD overheat</b> .....	150
<b>7-4-7. The motor stalls during acceleration and deceleration</b> .....	151
<b>7-4-8. Under voltage</b> .....	151
<b>8. MAINTENANCE</b> .....	<b>152</b>
<b>8-1. ROUTINE MAINTENANCE</b> .....	152
<b>8-2. REGULAR MAINTENANCE</b> .....	152
<b>8-3. WARRANTY OF FREQUENCY CONVERTER</b> .....	153
<b>APPENDIX</b> .....	<b>154</b>
<b>APPENDIX A. EXTENSION CARD</b> .....	154
<b>Appendix A-1. Extension card functions</b> .....	154
<b>Appendix A-1-1. VH5-CC100 EtherCAT card</b> .....	154
<b>Appendix A-1-2. VH5-CN100 Canopen card</b> .....	154
<b>APPENDIX B. COMMUNICATION PROTOCOL</b> .....	<b>155</b>
<b>Appendix B-1. Communication protocol overview</b> .....	155
<b>Appendix B-2. Communication protocol explanation</b> .....	155
<b>Appendix B-2-1. Communication protocol mode</b> .....	155
<b>Appendix B-2-2. Communication port</b> .....	155
<b>Appendix B-3. Modbus-RTU protocol</b> .....	156
<b>Appendix B-3-1. Character structure</b> .....	156
<b>Appendix B-3-2. Communication data structure</b> .....	156
<b>Appendix B-3-3. Communication protocol parameter address</b> .....	158

---

# Attention

## Safety precautions

### (1) Definition of safety information



Notice

Steps taken to ensure proper operation.



Danger

If you do not comply with the relevant requirements, it will cause serious personal injury, or even death.



Warning

Failure to comply with the requirements may result in personal injury or equipment damage.

### (2) Safety notice

#### ● Unpacking check



Notice

1. Before unpacking, please check whether the outer package of the product is in good condition, and whether there is damage, moisture, deformation, etc.
2. Before unpacking, please check whether the external model identification of the packing box is consistent with that of the ordered model.
3. When unpacking, please check the surface of products and accessories for damage, corrosion, bruise, etc.
4. After unpacking, please check whether the product name plate label is consistent with the external model label.
5. After unpacking, check whether the internal accessories are complete, including operation panel and expansion card.

Note: If any of the above five points appear during unpacking, please contact the local Xinje office or Xinje dealer in time, and we will solve the problem for you as soon as possible.

#### ● Installation



Notice

1. When carrying, please hold the bottom of the machine.  
If you only hold the panel, there is a risk that the main body will fall and hurt your feet.
2. Please install it on the plate of metal and other non combustible materials.  
If it is installed on flammable materials, there is a risk of fire.
3. When more than two inverters are installed in the same control cabinet, please set the cooling fan and keep the air temperature at the air inlet below 40 °C.  
Due to overheating, it can cause fire and other accidents.

● Wiring



Notice

1. Please confirm whether the rated voltage of AC main circuit power supply is consistent with that of frequency converter.  
Danger of injury and fire.
2. Do not do voltage withstand test on the inverter.  
Will cause damage to semiconductor components, etc.
3. Please connect the brake resistor or brake unit according to the wiring diagram.  
There is a risk of fire.
4. Please use the screw driver with specified torque to fasten the terminal.  
There is a risk of fire.
5. Do not connect the input power line to the output U, V and W terminals.  
If the voltage is applied to the output terminal, the inverter will be damaged internally.
6. Do not connect the phase-shifting capacitor and LC / RC noise filter to the output circuit.  
It will cause internal damage to the inverter.
7. Do not connect the electromagnetic switch and contactor to the output circuit.  
When the frequency converter is running with load, the surge current generated by the action of electromagnetic switch and electromagnetic contactor will cause the over-current protection circuit of the frequency converter to act.
8. Do not remove the front panel cover.  
May cause internal damage to the inverter.



Danger

1. Before wiring, please make sure that the input power has been cut off.  
Danger of electric shock and fire.
2. Ask electrical engineering professionals to do wiring operation.  
Danger of electric shock and fire.
3. The grounding terminal must be reliably grounded.  
Danger of electric shock and fire.
4. After the emergency stop terminal is connected, be sure to check whether its action is effective.  
There is a risk of injury. (the responsibility for wiring shall be borne by the user)
5. Do not touch the output terminal directly, do not connect the output terminal of the inverter with the cover, and do not short circuit between the output terminals. There is danger of electric shock and short circuit.
6. After cutting off the AC power supply, before the indicator light of the AC motor driver goes out, it means that there is still high voltage inside the AC motor driver, which is very dangerous. Please do not touch the internal circuit and components.

---

- Maintenance and inspection



#### Notice

1. The keyboard, control circuit board and driver circuit board are equipped with CMOS integrated circuits. Please pay special attention when using.  
If you touch the circuit board directly with your fingers, static induction may damage the integrated chip on the circuit board.
2. Do not change the wiring or remove the terminal wiring during power on. Do not check the signal during operation. It will damage the equipment.



#### Danger

1. Do not touch the terminal of the inverter, there is high voltage on the terminal.  
Danger of electric shock.
2. Before power on, be sure to install the terminal cover. When removing the cover, be sure to disconnect the power supply.  
Danger of electric shock.
3. Non professional technicians are not allowed to carry out maintenance and inspection.  
Danger of electric shock.



---

## Precautions for use

- Constant torque and low speed operation

When the inverter with ordinary motor runs at low speed for a long time, the motor life will be affected due to the poor heat dissipation effect. If low speed constant torque long-term operation is needed, special frequency conversion motor must be selected.

- Confirmation of motor insulation

When using VH5 series frequency converter, please confirm the insulation of the motor before connecting the motor, so as to avoid damaging the equipment. In addition, when the motor is in a bad environment, please check the insulation of the motor regularly to ensure the safe operation of the system.

- Negative torque load

For such occasions as lifting the load, there will often be negative torque, and the frequency converter will trip due to over-current or over-voltage fault. At this time, the selection of braking resistance should be considered.

- Mechanical resonance point of load device

In a certain output frequency range, the inverter may encounter the mechanical resonance point of the load device, which must be avoided by setting the jump frequency.

- Capacitors or varistors to improve power factor

As the output voltage of the frequency converter is pulse wave type, if the output side is installed with capacitors to improve the power factor or varistors for lightning protection, it will cause the frequency converter fault trip or device damage. Please remove it. In addition, it is recommended not to add air switch and contactor and other switching devices on the output side.

- The use of derating when setting the fundamental frequency

When the fundamental frequency is lower than the rated frequency, please pay attention to the derating of the motor to avoid overheating and burning.

- Operate at frequency above 50 Hz

If the frequency exceeds 50 Hz, in addition to considering the vibration and noise increase of the motor, it is also necessary to ensure the speed range of the motor bearing and mechanical device, and make sure to check in advance.

- Electronic thermal protection value of motor

When selecting the suitable motor, the inverter can implement thermal protection for the motor. If the rated capacity of motor and frequency converter does not match, the protection value must be adjusted or other protection measures must be taken to ensure the safe operation of motor.

- Altitude and derating

In the area with altitude more than 1000 meters, the heat dissipation effect of frequency converter becomes worse due to the thin air, so it is necessary to reduce the rating.

- About the protection level

The protection grade IP20 of VH5 series frequency converter is achieved when the status display unit or keyboard is selected.

- Notes on scrapping

When scrapping the inverter, please pay attention to:

When the electrolytic capacitors in the main circuit and printed circuit board are burned, they may explode.

Toxic gases are produced when plastic parts are burned. Please treat as industrial waste.

# 1. Product introduction

## 1-1. Product overview

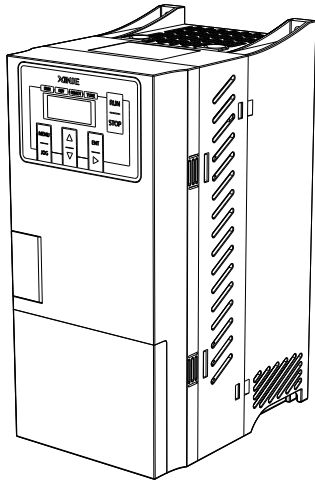

VH5 series is a simple inverter developed by Xinje company. The product adopts vector control technology, which realizes asynchronous open-loop vector control, and strengthens the reliability and environmental adaptability of the product.

### 1-1-1. Naming rule

$$\text{VH } \underline{5} \text{ - } \underline{4} \text{ } \underline{5P5} \text{ - } \underline{B}$$

$$\textcircled{1} \textcircled{2} \quad \textcircled{3} \textcircled{4} \quad \textcircled{5}$$

①	Product identification	VH: General purpose inverter
②	Product series	5: communication type open-loop vector inverter
③	Input voltage level	4: AC 380V 2: AC220V
④	Power level	1P5: 1.5KW 0P7: 0.75KW The decimal point is represented by P
⑤	Brake unit	B: built-in brake unit Vacant: none

## 1-2. Specification

### 1-2-1. Technical specification

Model	VH5-____-B	20P7	21P5	22P2	40P7	41P5	42P2	43P7	45P5
Adaptive motor (KW)		0.75	1.5	2.2	0.75	1.5	2.2	3.7	5.5
Input rated current (A)		5.6	9.3	12.7	3.4	5.0	5.8	10.5	14.6

Power supply capacity (KVA)	1.5	3.0	4.5	1.5	3.0	4.0	5.9	8.9
Output rated current (A)	4.0	7.0	9.6	2.1	3.8	5.1	9.0	13.0

## 1-2-2. General specification

Item		Specification	
Input	Rated voltage, frequency	Three phase 380V: three phase 380V, 50Hz/60Hz 220V: single phase 220V, three phase 220V, 50Hz/60Hz	
	Allowable voltage fluctuation range	-15%~+15%, voltage unbalance rate <3%	
Output	Voltage	0~input voltage	
	Frequency	0~500Hz	
Control	Control motor type	Asynchronous motor	
	Control performance	Vector control without speed sensor (SVC)	V/F control (VVF)
	Speed accuracy	±0.5%	±1%
	Speed fluctuation	±0.3%	±0.5%
	Speed range	1: 100	1: 50
	Startup torque	0.5Hz: 150%	1.0Hz: 150%
	Torque accuracy	±10% of rated torque	//
	Torque response	≤20ms	//
	Overload ability	SVC: 150% rated current 53s; 180% rated current for 1s VF: 150% rated current: 74s	
	Frequency accuracy	Low frequency operation mode: 0.01Hz High frequency operation mode: 0.1Hz	
	Frequency resolution	Digital setting: 0.01Hz, Analog setting: max frequency×0.025%	
Control terminal input	Input channel	Up to 4 channels digital input X, 1 channel analog input (0~10V/0~20mA)	
	Output channel	Support 1 channel digital output, 1 channel analog output (0~10V/0~20mA), 1 channel relay output (1 pair of NO, 1 pair of NC)	
Function	Startup command setting	Communication setting (Modbus, CANopen, EtherCAT), operate panel setting, terminal setting	
	Frequency setting mode	Communication setting (Modbus, CANopen, EtherCAT), operate panel setting, terminal setting, analog AI setting, multi-speed setting, simple PLC setting, PID setting, main and auxiliary setting	
	Typical function	Frequency main and auxiliary operation, reverse inhibition, torque boost, nine kinds of V/F curve settings, five segments of AI curve settings, acceleration and deceleration curve settings, terminal delay and filtering, terminal multi-function input and output, DC braking, energy consumption braking, inching operation, 16 segments of speed, built-in two channels of PID, speed tracking restart, carrier modulation, fault recording, fault self reset, pre-excitation start, 30 groups of user defined parameters	
	Important function	Carrier modulation, torque control, motor auto-tuning, current limiting control, over-voltage control, under voltage control, speed tracking, droop control, vibration suppression, over-voltage and over-current stall control,	

Item		Specification
		automatic voltage regulation (AVR), automatic energy-saving operation, etc
	Protection function	Power on motor short-circuit detection, input and output phase loss protection, over-current protection, over-voltage protection, under voltage protection, overheat protection, overload protection, under load protection, over-current and voltage stall protection, relay closing protection, terminal protection, instantaneous power failure non stop, etc
	Energy consumption braking	built-in braking unit as standard, can connect external brake resistor
	DC reactor	18.5kw and above are built-in DC reactors
	Common DC bus	When the frequency converter decelerates, it shares the regenerative energy, improves the braking ability, achieves the purpose of energy saving and saves the additional space and cost required by the resistance
Special functions	Multi-bus	Main unit Modbus, extensible EtherCAT and CANopen
	Multi-encoder	Differential input encoder, OC input encoder and resolver transformer
	LCD panel	LCD display, parameter setting, status monitoring, parameter copy, fault analysis and location, program download, mass storage of parameters
	Non stop when instantaneous power failure	In case of instantaneous power failure, the load feedback energy compensates for the decrease of voltage and keeps the inverter running for a short time
	Timing control	Timing control function: the time range is 0.1Min~6500.0Min
	Multi-motor switching	Two sets of motor parameters can realize the switching control of two motors
	Flexible and diversified terminal functions	Multi function terminal X has 51 types, Y has 42 types, AO has 19 kinds of logic function selection, meet the general inverter control function requirements
	Communication customization parameters	It is convenient for users to read and write the inverter parameters continuously
	Software	Rich background monitoring function, convenient for field data collection and debugging
Display and keyboard	Keyboard display	It can display the set frequency, output frequency, output voltage, output current, input and output status and other parameters
	Button locking	Realize the partial or total locking of keys to prevent false triggering
	Parameter copy	Standard LED single display numeric keyboard, optional LCD English display keyboard (parameter download)
	Optional accessories	LCD keyboard
Environment	Using place	Indoor, free from direct sunlight, dust, corrosive gas, combustible gas, oil mist, water vapor, dripping or salt, etc
	Altitude	Below 1000 meters. (derating is required when the height is higher than 1000m, and the output current will be reduced by about 10% of the rated current when the height is increased every 1000m.)
	Ambient temperature	-10°C~+40°C (When the ambient temperature is between 40°C and 50°C, please reduce the rating or enhance the heat dissipation)
	Ambient humidity	Less than 95%RH, no condensation

Item		Specification
	Vibration	Less than 5.9 m/s <sup>2</sup> (0.6G)
	Storage temperature	-40°C~+70°C
	Protection level	IP20
	Cooling mode	Forced air cooling
Installation mode		Wall mounted and embedded

## 2. Installation and wiring

### 2-1. Installation environment

#### 2-1-1. Environment requirements

- ◆ It should be installed in a well ventilated indoor place, and the ambient temperature should be within the range of -10°C ~ 40°C. If the temperature exceeds 40°C, it needs external forced cooling or derating.
- ◆ Avoid installation in places with direct sunlight, dusty, floating fiber and metal powder.
- ◆ It is strictly forbidden to install in places with corrosive and explosive gas.
- ◆ The humidity should be lower than 95% RH without condensation.
- ◆ It is installed in the place where the fixed vibration is less than 5.9m/s<sup>2</sup> (0.6G).
- ◆ Be far away from EMI sources and other electronic equipment sensitive to EMI.

#### 2-1-2. Installation space and direction

- ◆ Generally, it should be installed vertically.
- ◆ Minimum requirements for installation spacing and distance.
- ◆ When multiple frequency converters are installed up and down, the middle part shall be equipped with guide plate.

### 2-1-3. Single installation

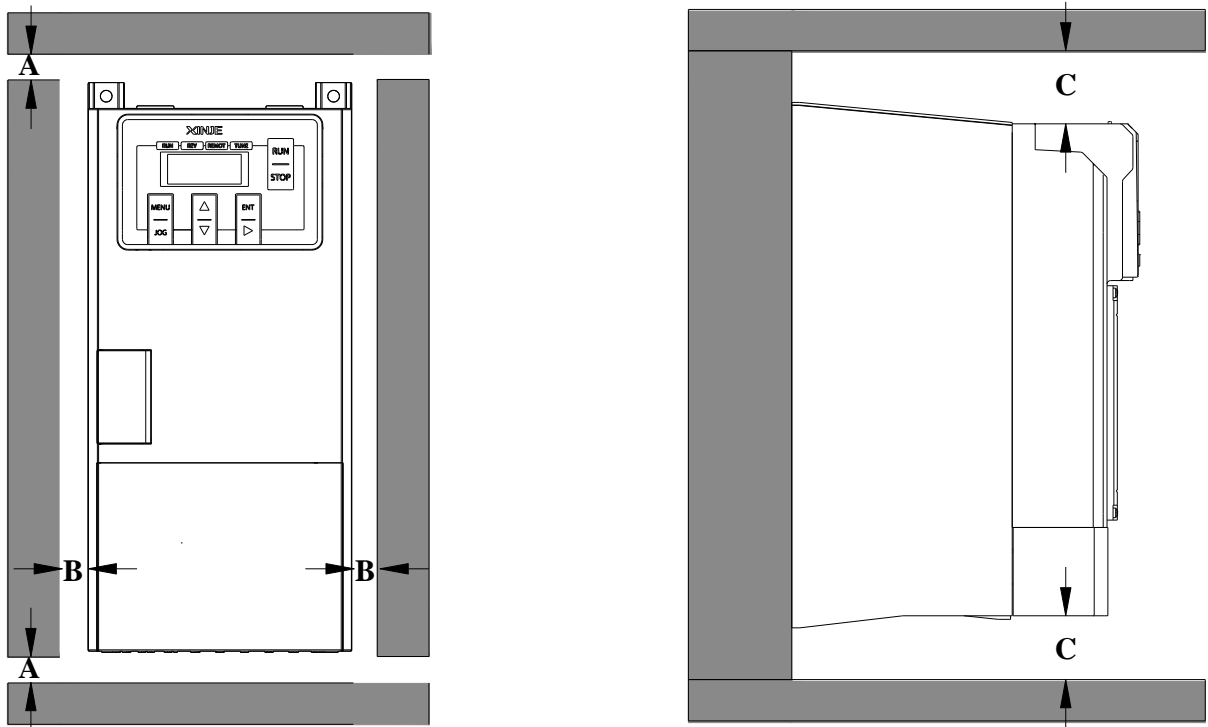

Note: the distance of A and B is more than 50 mm, and the distance of C is more than 100 mm.

### 2-1-4. Multiple installation

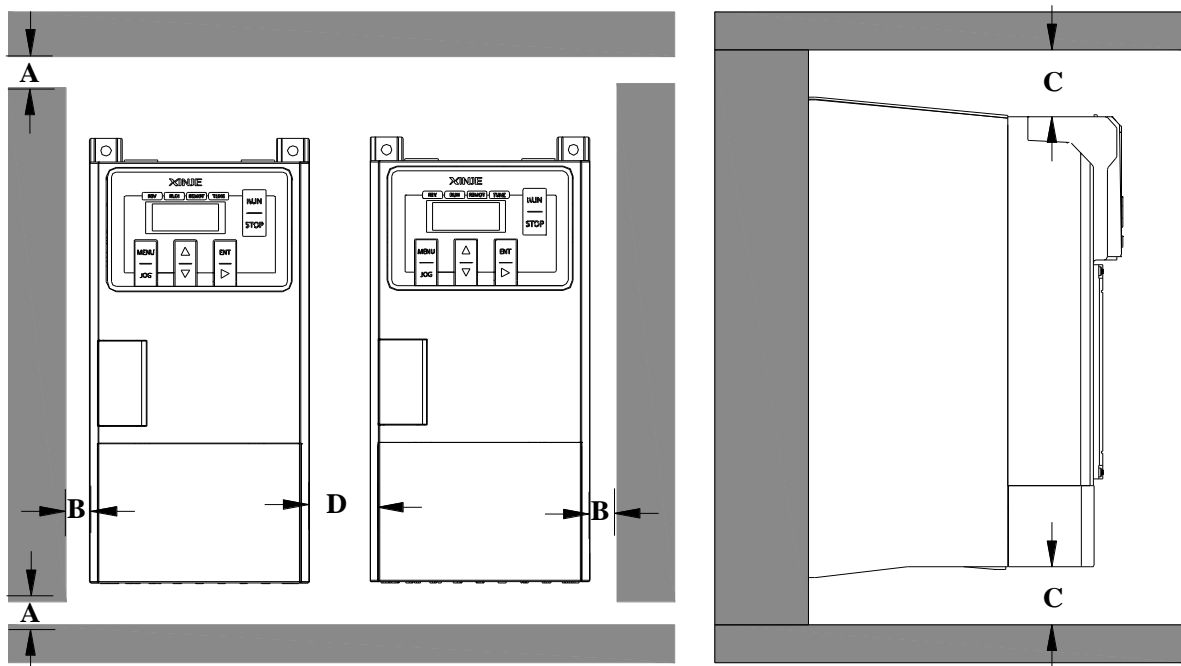

Note: the distance of A and B is more than 50mm, and the distance of C and D is more than 100mm.

### 2-1-5. Vertical installation

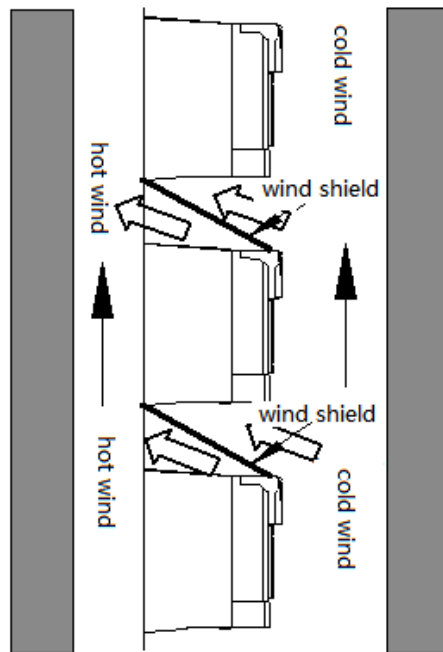

Note: when installing vertically, the wind shield must be added, otherwise it will cause mutual influence between multiple inverters, resulting in poor heat dissipation.

### 2-1-6. Extend the operate panel

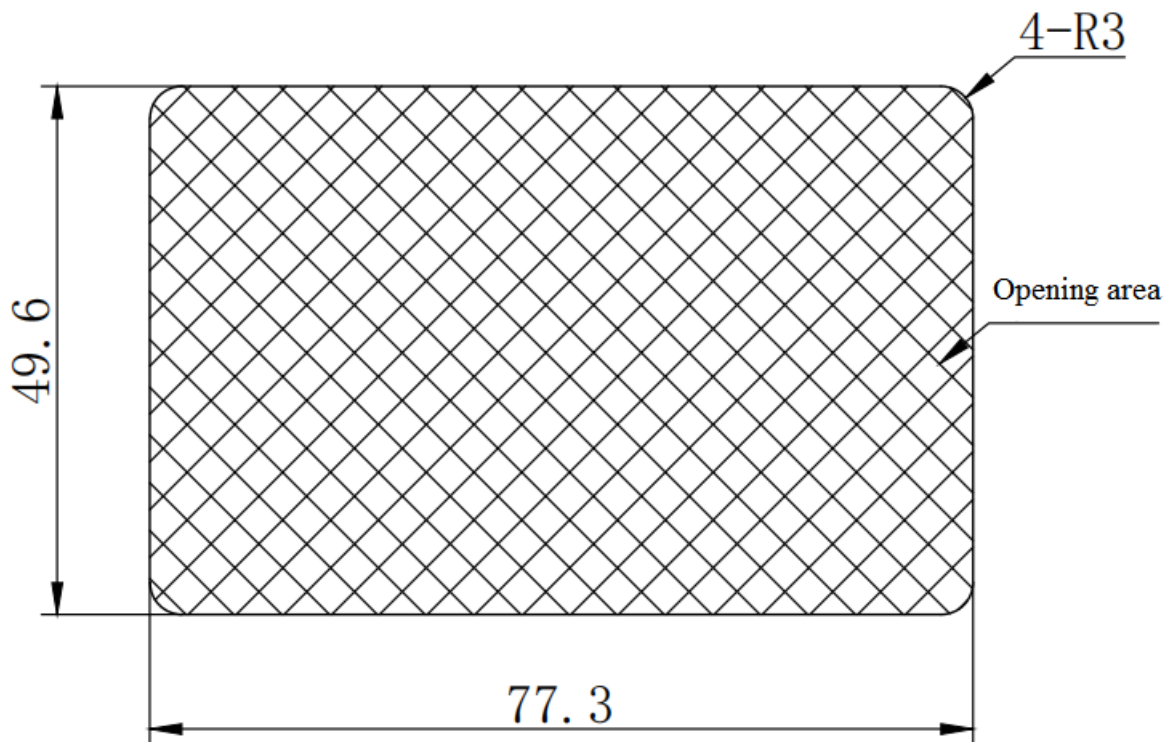

Installation instructions: according to the dimensions in the figure above, open the hole on the outer surface of the operation panel to be installed. Then, according to the schematic diagram below, remove the control panel, install it in the opening area, and push it in place.

When the operation panel is taken out, the schematic diagram of panel disassembly is as follows:

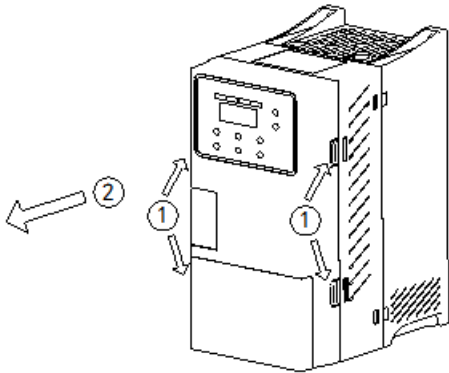

Press the snap-fit to take out

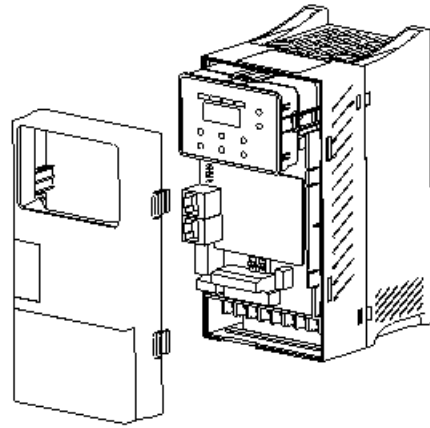

the front cover is taken out

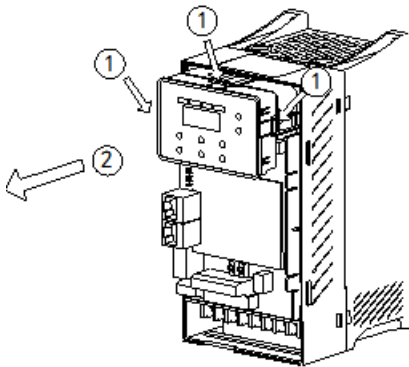

Press the snap-fit to take out

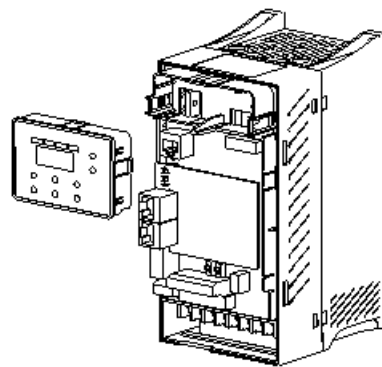

the operate panel is taken out

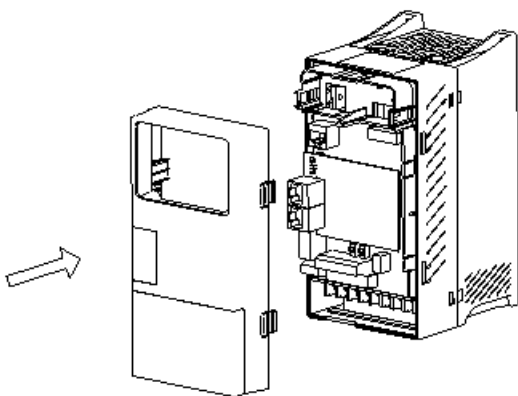

Align the cover and push them in the direction of the arrow

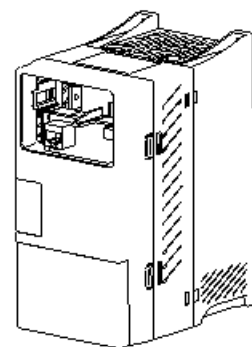

finish the front cover installation



## 2-2. Wiring notice



### Notice

- ◆ Ensure that the power supply has been completely cut off for more than 15 minutes before wiring, otherwise there is a risk of electric shock.
- ◆ It is strictly forbidden to connect the power cable with the output terminal U, V and W of the frequency converter.
- ◆ There is leakage current in the inverter itself. In order to ensure safety, the inverter and motor must be grounded safely. Generally, the diameter of grounding wire is more than 3.5mm<sup>2</sup> copper wire, and the grounding resistance is less than 10Ω.
- ◆ The inverter has passed the withstand voltage test before leaving the factory, and the user cannot carry out the withstand voltage test on the inverter.
- ◆ The electromagnetic contactor, absorption capacitor or other resistance capacitance absorption device shall not be installed between the frequency converter and the motor.
- ◆ In order to provide the convenience of input side over-current protection and power failure maintenance, the frequency converter shall be connected with the power supply through the circuit breaker.
- ◆ The input and output circuits of control terminals shall be connected with twisted wires or shielded wires of more than 0.75mm<sup>2</sup>. One end of the shielding layer shall be suspended, and the other end shall be connected with the grounding terminal PE of frequency converter, and the wiring length shall be less than 50m.



### Danger

- ◆ Ensure that the power supply of the inverter has been completely cut off, all LED indicators of the operation keyboard are off, and wait for more than 15 minutes before wiring operation.
- ◆ The internal wiring can be started only after the DC voltage between P+ and P- of the internal electrolytic capacitor of the frequency converter is reduced to less than DC36V.
- ◆ The wiring operation can only be carried out by trained and authorized qualified professionals.
- ◆ Before power on, pay attention to check whether the voltage level of the frequency converter is consistent with the supply voltage, otherwise it may cause casualties and equipment damage.

## 2-3. Main circuit wiring

### 2-3-1. Wiring diagram

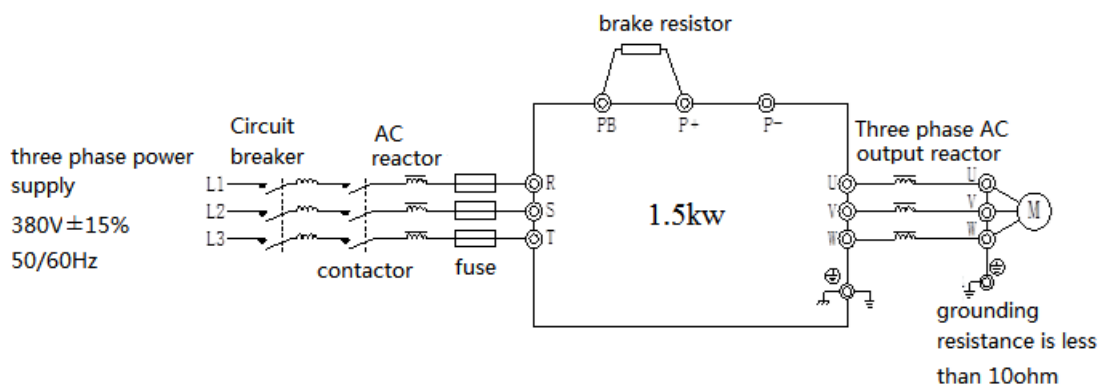

Note: circuit breaker, contactor, AC reactor, fuse, brake resistor and output reactor are optional parts. Please refer to chapter 6 for details.

## 2-3-2. Arrangement and description of main circuit terminals

- VH5-45P5-B main circuit terminals

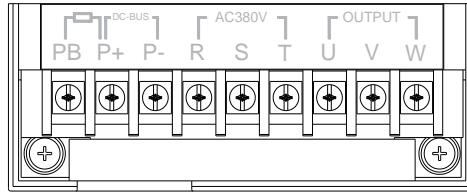

- VH5-40P7-B/VH5-41P5-B/VH5-42P2-B/ VH5-43P7-B main circuit terminals

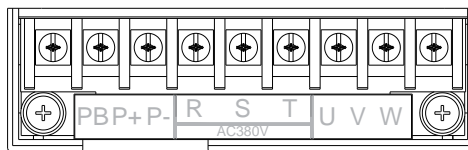

- VH5-20P7-B/VH5-21P5-B/VH5-22P2-B main circuit terminals

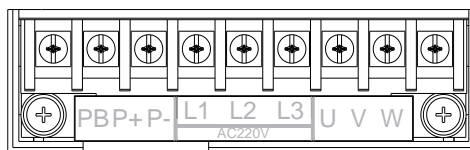

- Main circuit terminal description

Terminal	Name	Description
R, S, T	Three phase power supply input	AC three phase power supply input
U, V, W	VFD output terminal	Connect to the three phase motor
PE	Grounding terminal	Connect to the ground
P+, PB	Brake resistor terminal	Connect to the brake resistor
P+, P-	DC bus +/-	Common DC bus input

Note:

(1) Input power supply R, S, T

- ① There is no phase sequence requirement for input side wiring of frequency converter.
- ② Circuit breaker, contactor, AC reactor, fuse, brake resistor and output reactor are optional parts. Please refer to chapter 6 for details.

(2) P+, P-

- ① After the power failure, there is residual voltage between P + and P -, all the LED indicator lights of the operation keyboard go out, and wait for more than 15 minutes before wiring operation.
- ② Do not connect the brake resistor directly to the bus, otherwise the inverter will be damaged or even fire.

(3) P+, PB

- ① Refer to the recommended value for brake resistance selection, and the wiring distance is less than 5m, otherwise the inverter may be damaged.

(4) Output U, V, W

- ① Please refer to chapter 6 for output cable.
- ② No capacitor or surge absorber can be connected to the output side of the inverter, otherwise the inverter will be damaged.
- ③ When the length of motor cable is more than 100m, it is easy to produce electrical resonance due to the influence of distributed capacitance, so it is necessary to install AC output reactor near the frequency converter.

(5) Grounding terminal PE

- ① The terminal must be reliably grounded, and the grounding resistance must be less than  $10\Omega$ . Otherwise, the equipment will work abnormally or even be damaged.
- ② It is not allowed to share the grounding terminal PE and the power zero cable N terminal.
- ③ The impedance of protective grounding conductor must meet the requirement of withstanding large short-circuit current in case of fault.
- ④ The size of protective grounding conductor shall be selected according to the table below.

Sectional area of single phase cable (S)	Minimum sectional area of protective conductor ( $S_p$ )
$S \leq 16\text{mm}^2$	S
$16\text{mm}^2 < S \leq 35\text{mm}^2$	$16\text{mm}^2$
$35\text{mm}^2 < S$	$S/2$

- ⑤ Yellow and green cable must be used for protective grounding.

### 2-3-3. Wiring process of main circuit

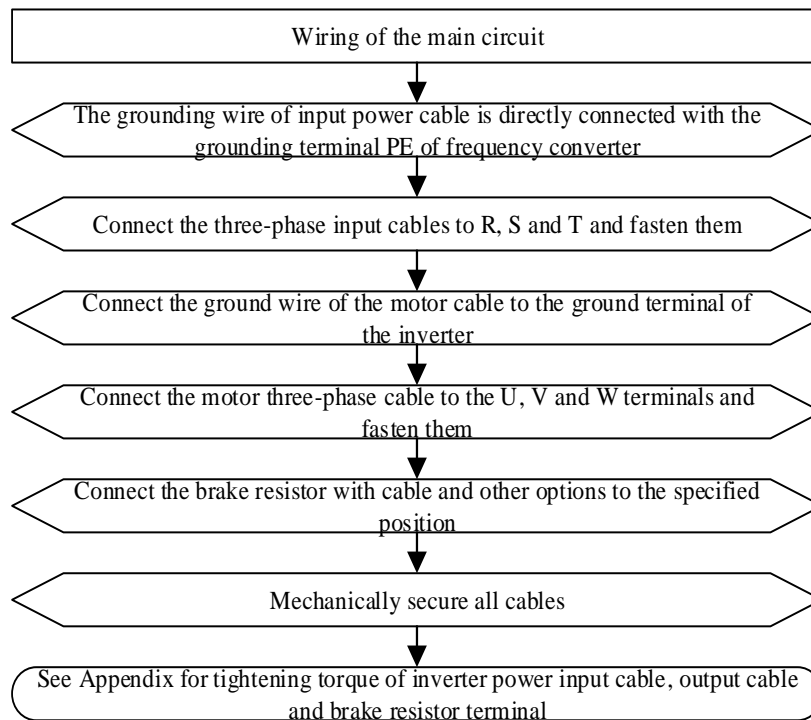

## 2-4. Configuration and wiring of the control circuit

### 2-4-1. Control circuit terminals

(1) VH5 series VFD control terminals

TA	TB	TC	X1	X3	COM	24V	AI	GND	10V	
			X2	X4	Y1	0V	AO	485-	485+	

(2) Terminal description of control circuit

Type	Terminal	Name	Description
communication	485+ 485-	RS485 terminal	Standard RS485 communication interface, using twisted pair or shielded wire.
Power supply	10V-GND	+10V power supply	External + 10V power supply, maximum output current: 20mA. Generally used for external potentiometer speed regulation.
	24V-0V	DC 24V power supply	Provide + 24V power supply for terminal, maximum output current: 100 mA It is generally used as working power supply for digital input and output terminals. External load is not allowed to connect.
Analog input	AI-GND	AI	Select voltage/current input by DIP switch Input voltage range: 0~10V (Input impedance: 22k $\Omega$ ) Input current range: 0~20mA (Input impedance: 500 $\Omega$ )
Analog output	AO-GND	AO	Voltage output range: 0~10V. External load: 2k $\Omega$ -1M $\Omega$ Current output range: 0~20mA. External load less than 500 $\Omega$ Select voltage/current output by DIP switch
Common terminal	COM	Common terminal of input X	COM and 24 V are short circuited to form NPN input COM and 0V are short circuited to form PNP input When using external signal to drive X1 ~ X4, com needs to be connected with external power supply and disconnected from 24 V power supply of inverter body;
Digital input	X1	Input terminal 1	Optocoupler isolation input
	X2	Input terminal 2	Input impedance: R = 2K $\Omega$
	X3	Input terminal 3	The input voltage range is 9 ~ 30V. Compatible with bipolar input.
	X4	Input terminal 4	Note: VH5 does not support high speed pulse input
Digital output	Y1	Digital output terminal 1	Collector open circuit output Output voltage range: 0 ~ 24V Output current range: 0 ~ 50mA
Relay output	TA TB TC	Output relay	Programmable is defined as a variety of electrical output terminals, TA-TB: normally open TA-TC: normally closed

			Contactor capacity: AC250V/2A (COSΦ=1) AC250V/1A (COSΦ=0.4) DC30V/1A
--	--	--	---

**Note:**

- (1) Before the frequency converter is put into use, the terminal wiring and all jumper switches on the control board should be set correctly.
- (2) DIP switch:
  - S1: AI OFF = 0 - 10V, ON = 0 - 20mA, default is OFF
  - S2: AO OFF = 0 - 10V, ON = 0 - 20mA, default is OFF

### 2-4-2. Analog I/O wiring

(1) Analog input terminal AI wiring

AI terminal receives analog signal input, and AI dial switch can select input voltage (0 ~ 10V) or current (0 ~ 20mA). The specific wiring is shown in the figure below:

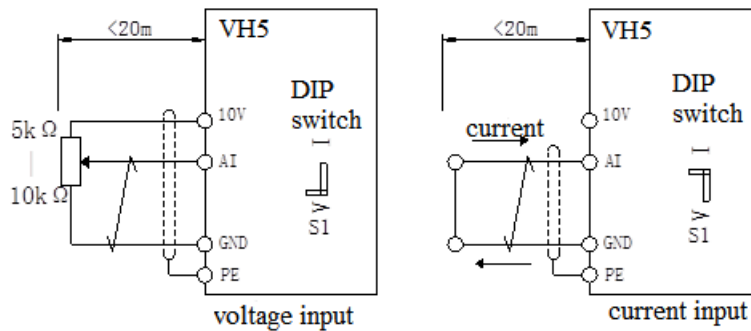

(2) Analog output terminal AO wiring

AO external analog meter can indicate a variety of physical quantities, AO dial switch can select output voltage (0 ~ 10V, external load 2KΩ – 1MΩ) or current (0 ~ 20mA, external load less than 500Ω). The terminal wiring mode is shown in the figure below.

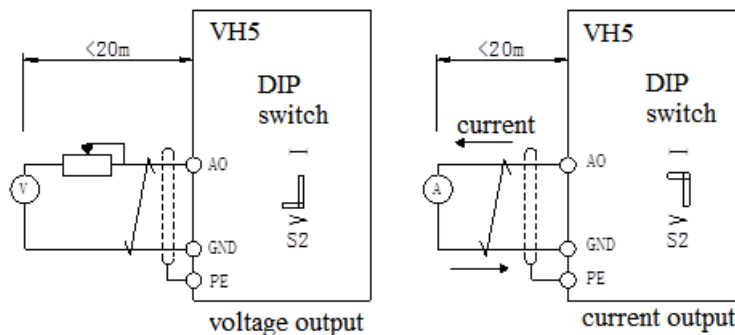

**Note:**

- (1) When using analog input, filter capacitor or common mode inductor should be installed between AI and GND.
- (2) The resistance ranges of the potentiometer connected between the control terminal 10V and GND is 5~10K.
- (3) Analog input and output signals are vulnerable to external interference. Shielded cables must be used for

wiring and well grounded. The length of wiring should be as short as possible and no more than 20m.

### 2-4-3. Digital I/O wiring

#### (1) Digital input terminal

Generally, shielded cables are required, and the wiring distance should be as short as possible, not more than 20m. When active driving mode is selected, necessary filtering measures should be taken for the crosstalk of power supply. The contact control mode is recommended, and the specific wiring diagram is as follows:

- Single inverter source wiring mode

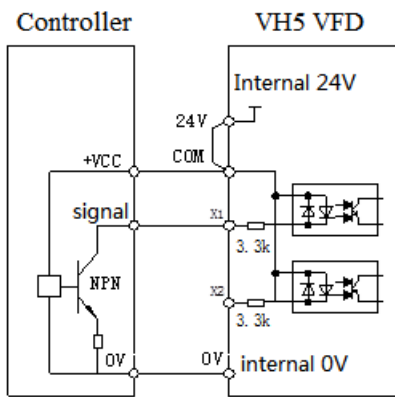

Single VFD uses internal 24V source wiring

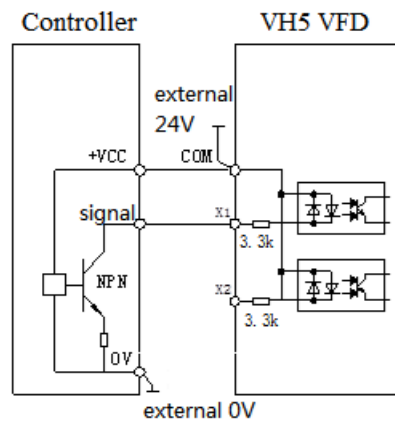

single VFD uses external 24V source wiring

It is the most common wiring mode to use the internal 24V power supply of frequency converter. The com of the inverter is short circuited to 24V, and the 0V of the inverter is connected to the 0V of the external controller.

If the external 24V is used, the com end of the frequency converter should be connected to the external 24V, and the external power supply 0V is connected to the corresponding X terminal through the control contact of the external controller.

- Multi-inverter source wiring mode

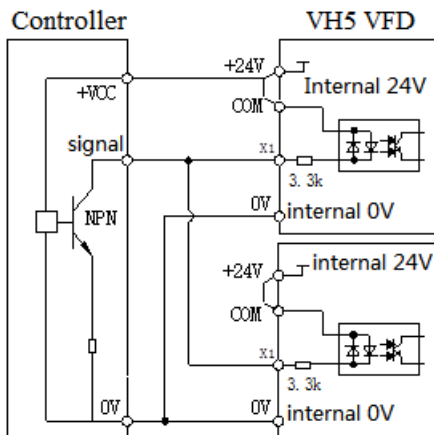

Multi-inverter uses internal 24V source wiring

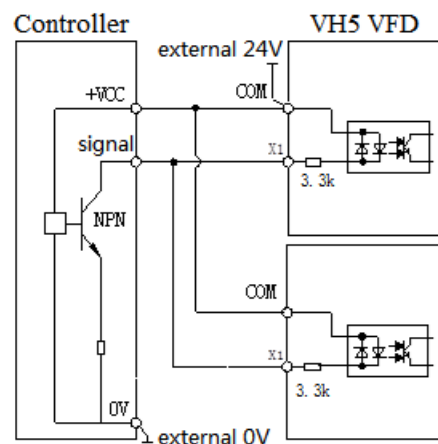

Multi-inverter uses external 24V source wiring

- Single inverter leakage wiring mode

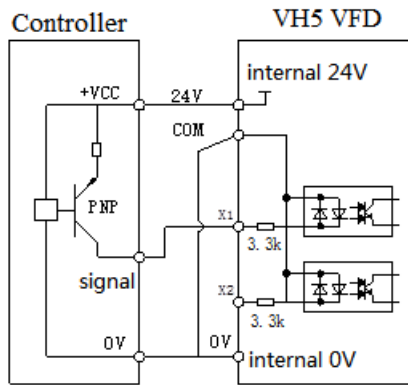

Single VFD uses internal 24V leakage wiring

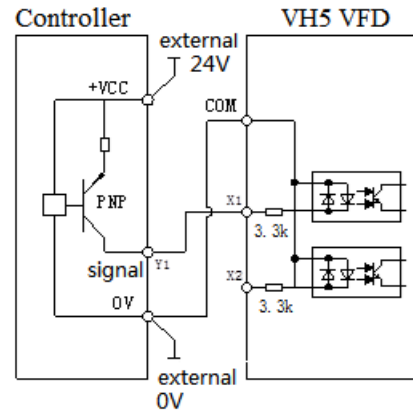

single VFD uses external 24V leakage wiring

If the internal 24V power supply of the converter is used, the 0V and com of the converter shall be short connected, and the 24V of the converter shall be connected with the common end of the external controller.

If external 24V is used, the com end of the converter shall be connected with external 0V, and the external power supply 24V shall be connected to the corresponding X terminal through the control contact of the external controller.

- Multi-inverter leakage wiring mode

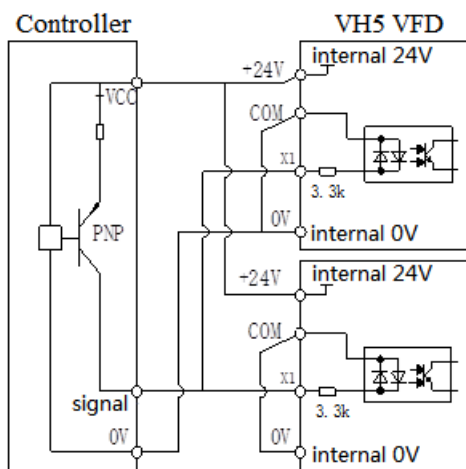

Multi-inverter uses internal 24V leakage wiring

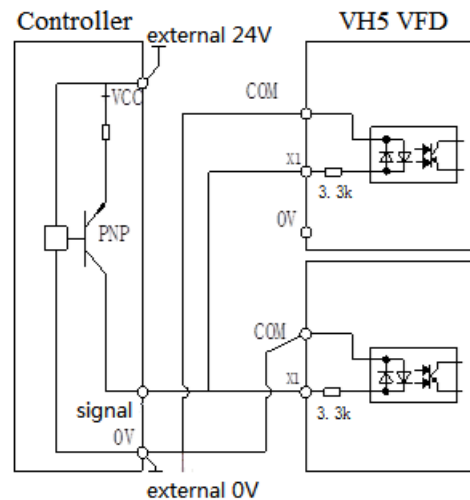

Multi-inverter uses external 24V leakage wiring

## (2) Digital output terminal

When the digital output terminal needs to drive the relay, freewheeling diodes should be installed on both sides of the relay coil. Otherwise, it is easy to damage the DC24V power supply. The driving capacity is no more than 50mA.

Note: the polarity of freewheeling diode must be correctly installed. As shown in the figure below. Otherwise, when the digital output terminal has output, the DC24V power supply will be burnt out immediately. Selection standard of freewheeling diode: the reverse withstand voltage is greater than 5 ~ 10 times of the load voltage, and the current is greater than the load current.

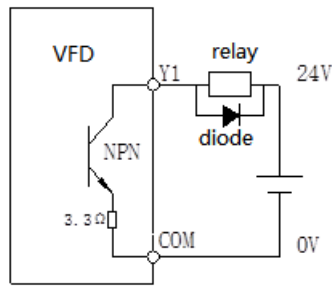

(3) Relay output terminal

Inductive loads (relays, motors, indicator lights) can cause voltage spikes when the current is cut off. The relay contacts are protected by varistors, and the inductive load is equipped with absorption circuits, such as varistors, RC absorption circuits, diodes, etc., to ensure the minimum interference current when turning off.

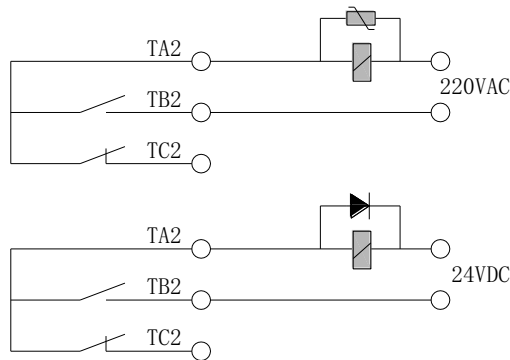

(4) Multiple inverters can be connected together through RS485 and controlled by PLC (or upper computer), as shown in the figure. With the increase of the number of connections, the communication system is more vulnerable to interference. It is suggested that the following wiring methods be adopted:

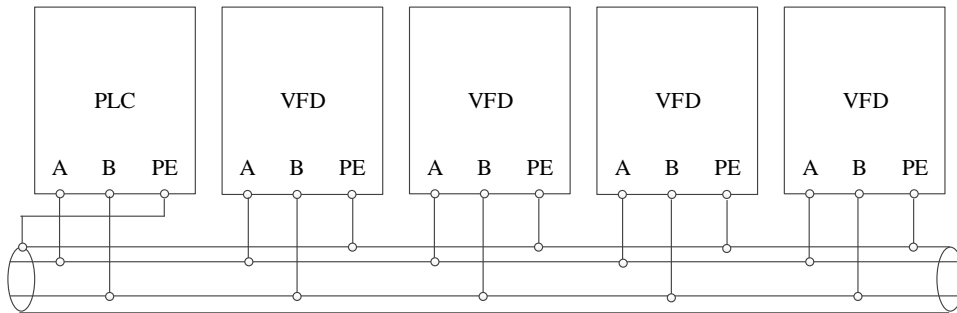



## 3. Operation and application

### 3-1. Operation panel

#### 3-1-1. Appearance

The operation panel and control terminal of the frequency converter can control the starting, speed regulating, stopping, braking, operation parameter setting and peripheral equipment of the motor. The appearance of the operation panel is shown in the figure below.

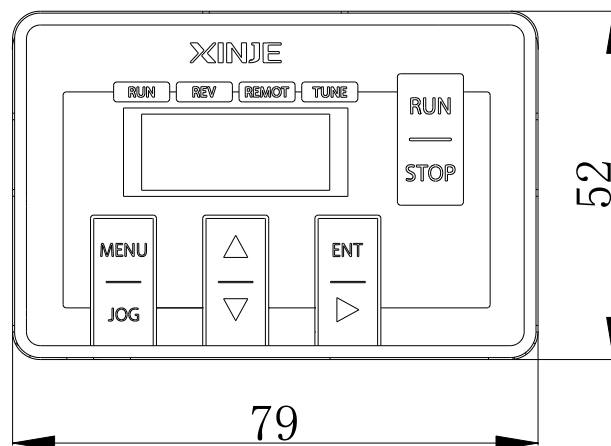

#### 3-1-2. Keyboard

There are 8 keys on the frequency converter operation panel, and the functions are defined as follows:

Button	Name	Function
MENU	Programming/exit	Enter or exit the programming status
ENT	Save/switch	Save the parameter or enter next menu in programming status
RUN	Forward run	Press this button to run forward in operation panel running command mode
STOP	Stop/reset	Stop/reset the fault
JOG	Multi-function	Set through P8-00
▲	Increase	Increase the value or pause frequency in operation
▼	Decrease	Decrease the value or pause frequency in operation
▶	Shift/monitor	In the editing state, you can choose to set the modification bit of the data; in other states, you can switch the display state and monitor parameters

#### 3-1-3. LED lights

There are 5-digit 7-segment LED digital tubes and 4 status indicators on the inverter operation panel.

The four status indicators are located above the LED tube, from left to right: RUN, REV, REMOT, TUNE. The following table describes the indicator lights.

Indicator lights	Meaning	Function
RUN	Operation indicator	On: running OFF: stop
REV	Forward/reverse operation indicator	ON: reverse operation OFF: forward operation Flashing: status switching
REMOT	Command source indicator	OFF: panel start/stop ON: terminal start/stop Flashing: communication start/stop
TUNE	Tuning indicator	Flash slowly: tuning status Flash quickly: fault status ON: torque status

### 3-1-4. Operation method

Through the operation panel, the inverter can be operated in various ways, for example:

#### (1) Parameter display and switch

Method 1:

Press  button, switch LED display parameter, set running display parameter P8-07 and P8-08, set stop display parameter P8-09.

When checking status monitoring parameters, you can press ENT key to switch back to the default display status of monitoring parameters. The default monitoring parameter of shutdown state is the setting frequency, and the default monitoring parameter of operation state is output frequency.

Method 2:

Check group U0 parameters, for example, U0-02.

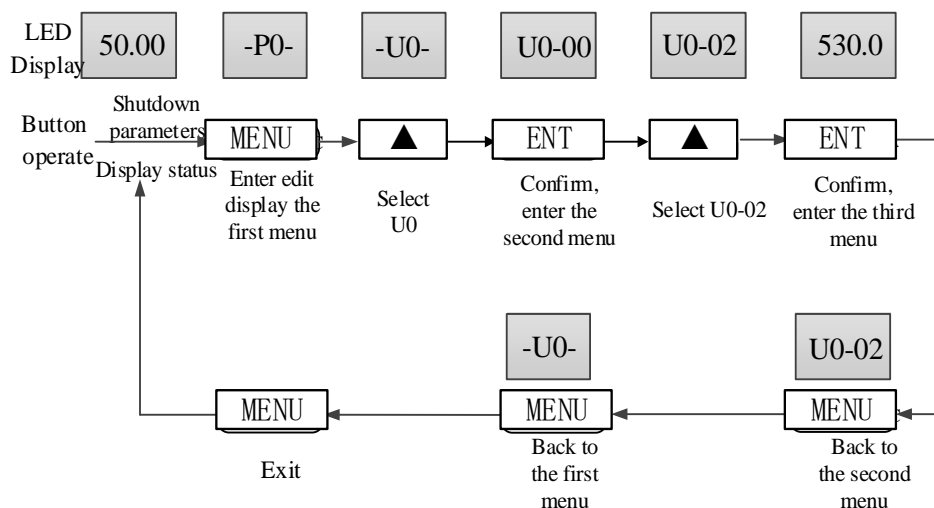

#### (2) Set the parameter

For example, the parameter PC-00 (jog frequency) is changed from 5.00Hz to 8.05Hz.

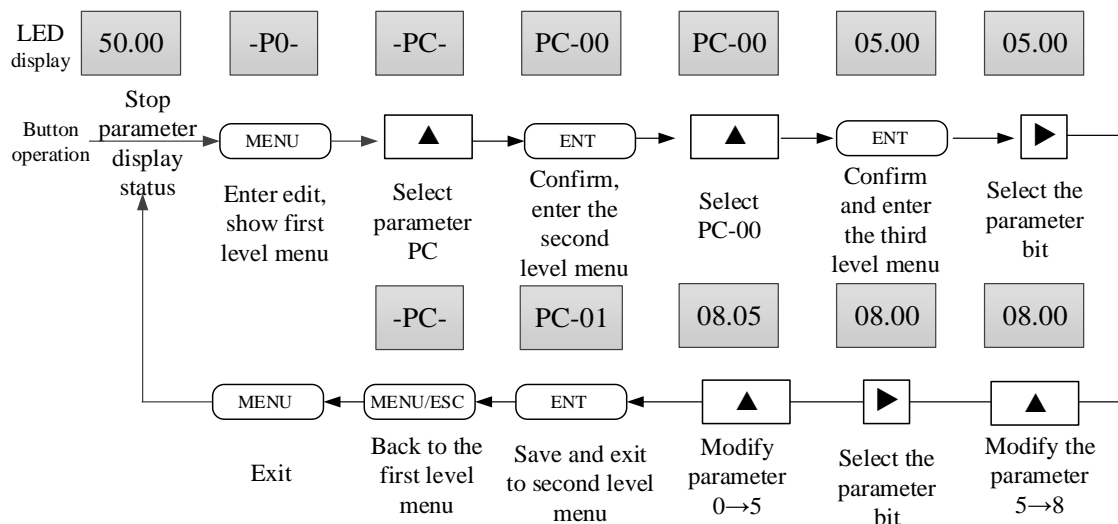

In the three-level menu, if the parameter has no flashing bit, it means that the parameter cannot be modified. The possible reasons are as follows:

- (1) The parameters are not modifiable, such as the actual detection state parameters, operation record parameters, etc;
- (2) This parameter can not be modified in the running state, and can be modified only after shutdown.

### (3) Jog operation

Suppose that the current operation command channel is the operation panel, in the shutdown state, press the JOG function key to select jog forward (P8-00 = 2), and the jog frequency is 5Hz.

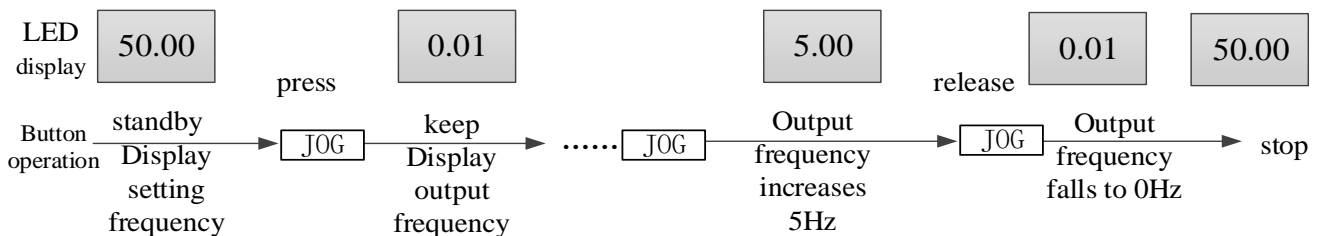

### (4) Set user password

Suppose that user password P8-03 has been set to 02345. The numbers in bold in the figure below indicate the flash position.

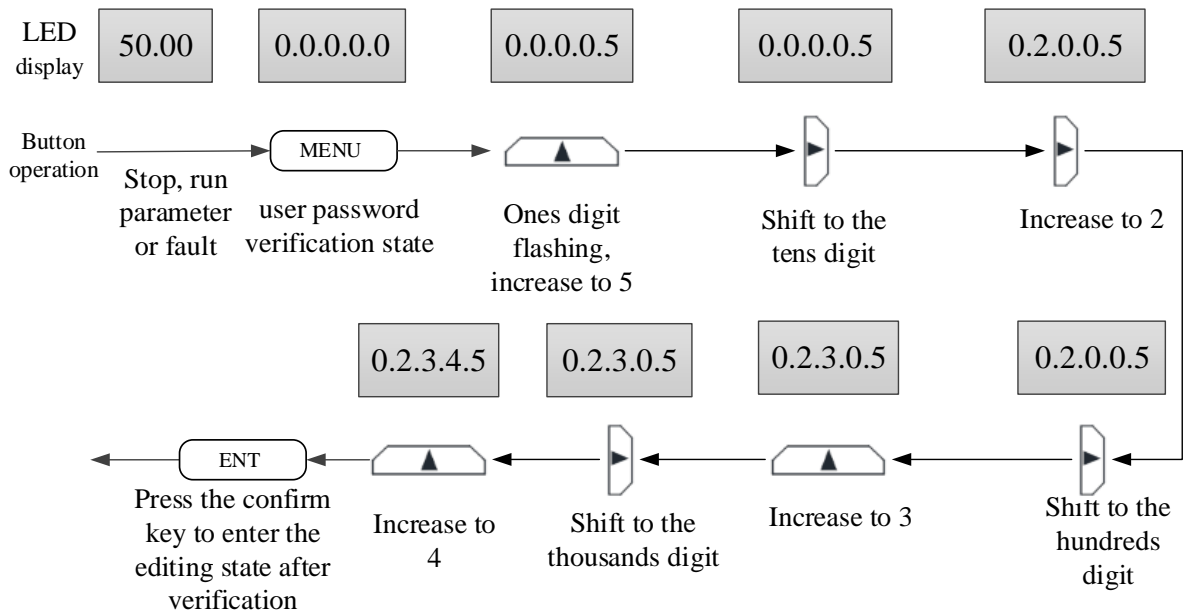

### (5) Check fault status and parameters







The method of fault status query is the same as group U0 monitoring parameters.

Note:

- User pressed  in fault status to check group P6 parameters.
- When the user checks the fault parameters, he can directly switch back to the fault code display state by pressing the MENU button.

### (6) Set frequency through buttons

Assuming the VFD is in shutdown parameter display status, P0-03 = 0, the operation mode is as follows:

- Frequency setting through digital setting
- Keep press  to increase ones bit, tens bit, hundreds bit...If release , and press , it will increase from ones bit again.
- Keep press  to decrease ones bit, tens bit, hundreds bit...If release  and press , It will decrease from ones bit again.

## 3-1-5. Multi-function buttons

The function of JOG button can be defined by P8-00, which is used to switch the menu, the rotation direction of frequency converter or jog. Please refer to the explanation of P8-00 function code for specific setting method.

## 3-1-6. Quick reference of parameters

There are many function codes in VH5 series. In order to facilitate users to quickly find the function codes, the frequency converter provides two methods to quickly find the function codes

(1) Users can select and customize the commonly used function codes, up to 32 of which can be customized to form a user-defined function code group. Users can determine the function parameters to be

displayed through PE group.

(2) The function codes which are different from the factory values are arranged automatically by the frequency converter for users to select quickly. Three ways to check the function codes:

Parameter display mode	Display
Function parameters	--A--
User defined parameters	--U--
User modified parameters	--C--

The three kinds of display mode are switched through the multi-function keys on the panel. After entering the function codes of each group, the search or modification method is the same as the previous keyboard operation.

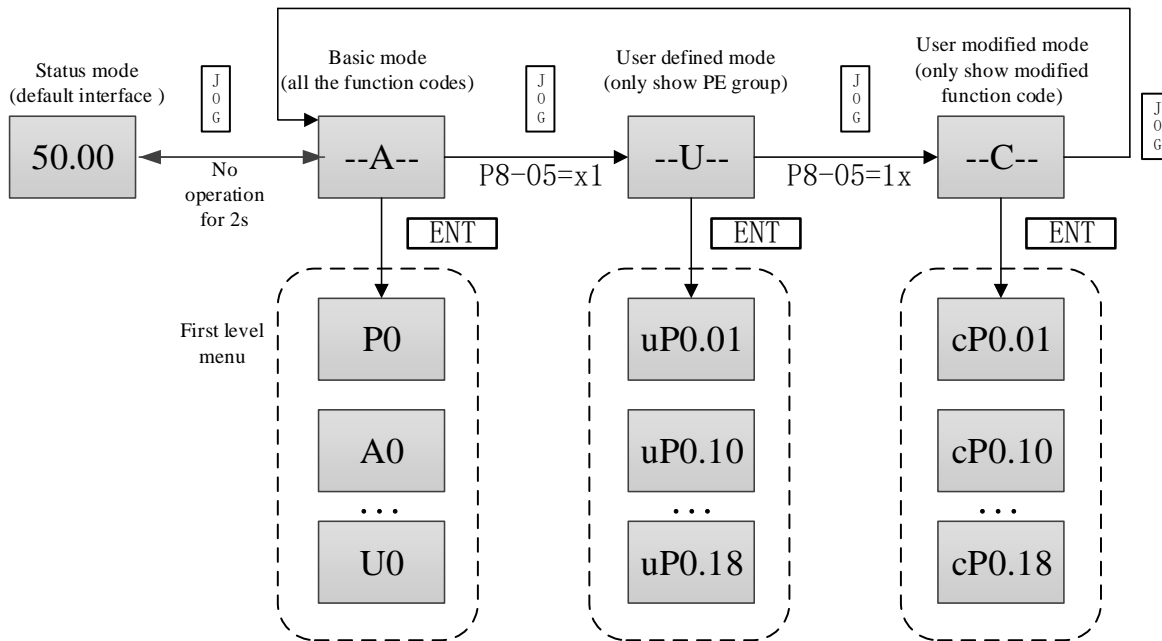

P8-05 is used to control the display of user defined group and user modified group parameters.

P8-05	Default value: 00		
	Set value	Tens bit	Ones bit
	Function	Group --C-- display	Group --U-- display
	Range	0: no display 1: display	0: no display 1: display

### Basic function codes

The basic function code group is the whole function code of the inverter. After entering, it is the level I menu. Please check them according to the operation mode described above.

### User defined function codes

The user defined menu is easy to check the general parameters. The display form of parameters in the user-defined menu is like "uP0.01", which represents the function parameter P0.01. The effect of modifying parameters in the user-defined menu is the same as that in the normal programming state.

The function parameters of user-defined menu come from group PE. If the function parameters are selected by group PE, and set to P0.00 means that they are not selected, and a total of 32 can be set. If "null" is displayed when entering the menu, it means that the user-defined menu is empty.

Users can customize and edit according to their specific needs.

### User modified function codes

In the group of function codes that have been changed by the user, only the current set value is listed. This is a

---

list generated automatically by the frequency converter, which makes it easy for users to quickly access the modified function code.

## **3-2. Power on**

### **3-2-1. Inspection after power on**

Please wiring according to the operation requirements provided in "EMC" of this manual.

### **3-2-2. Initial power on operation**

After checking the wiring and power supply, close the AC power switch on the input side of the frequency converter and power on the frequency converter. The LED on the operation panel of the frequency converter displays the dynamic picture of starting up, and the contactor pulls in normally. When the display character changes to the set frequency, it indicates that the frequency converter has been initialized. The initial power on operation process is shown in the figure below:

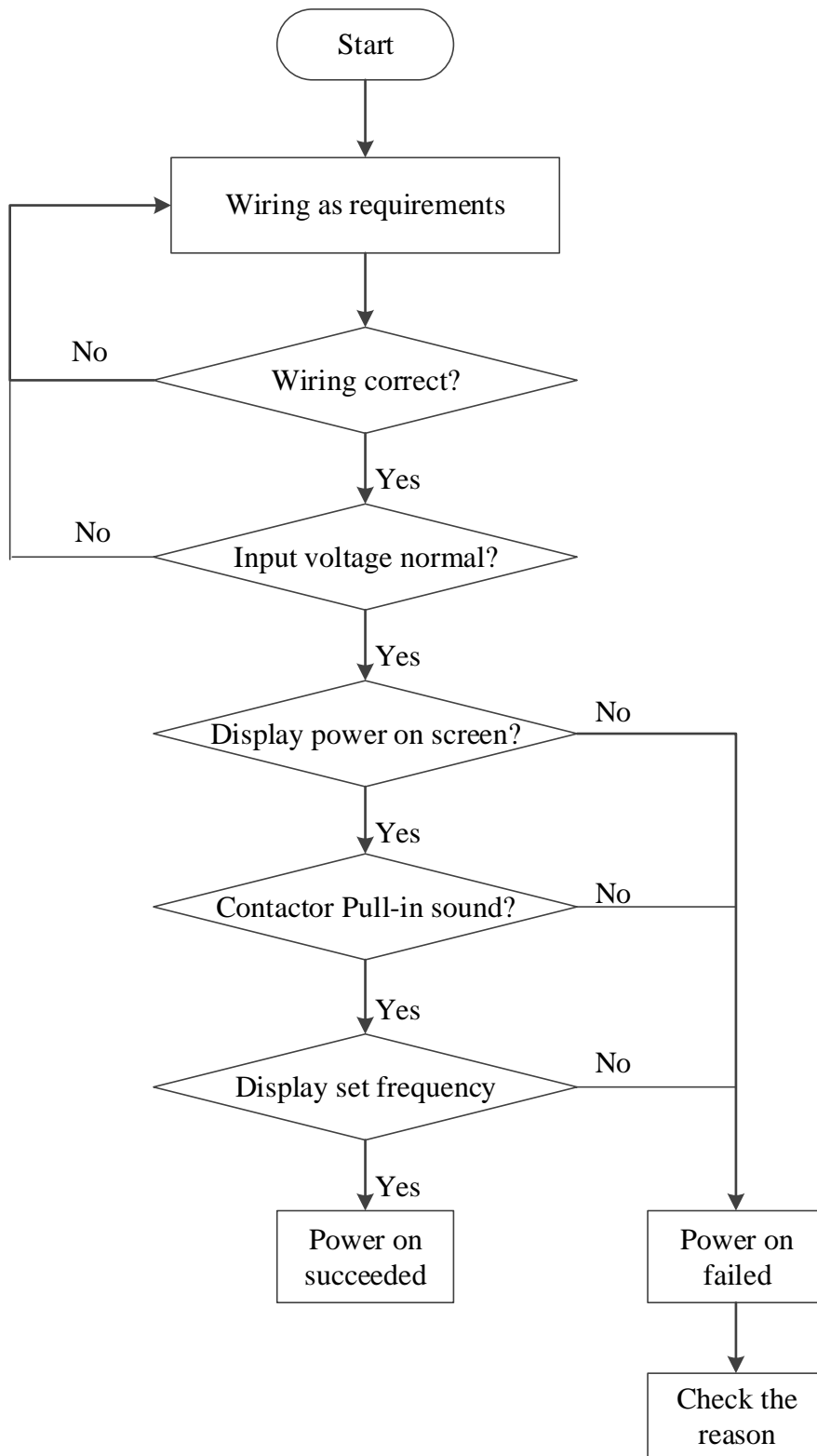

### 3-2-3. Start to debug

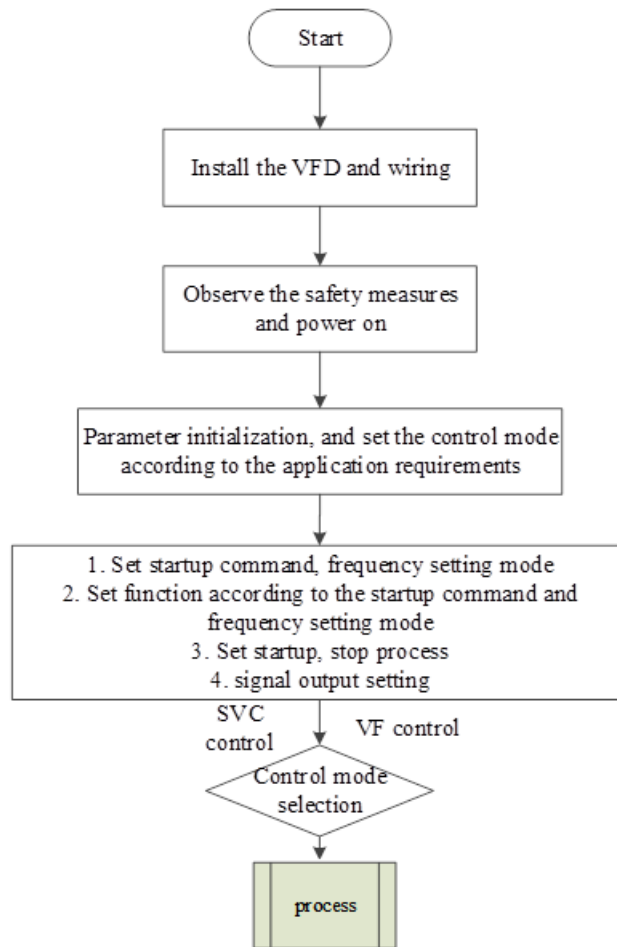



### 3-2-4. Debugging process

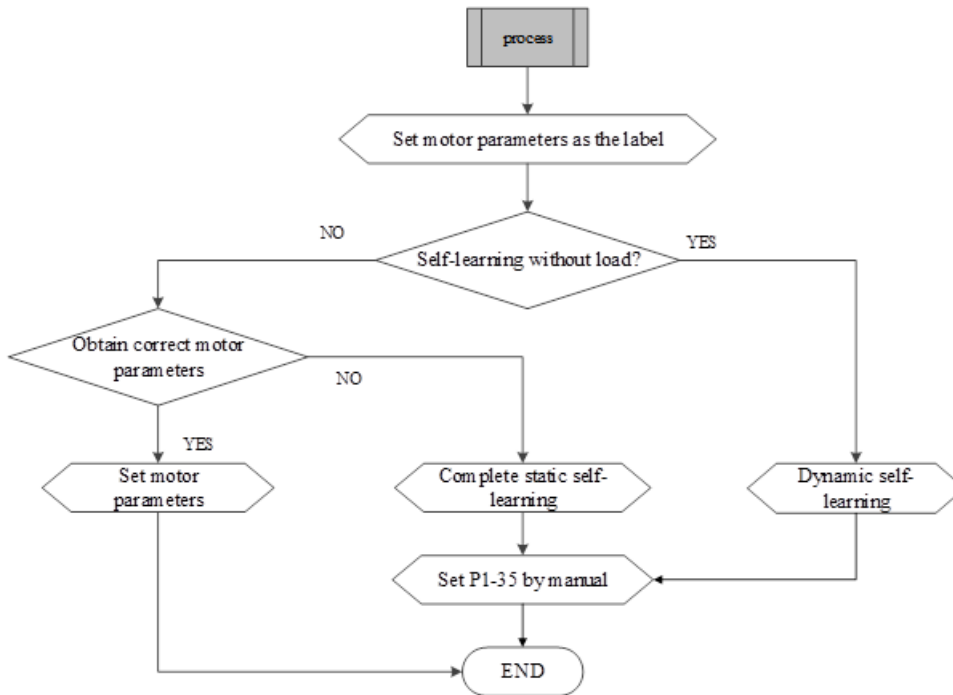

## 3-3. Start stop of the VFD

### 3-3-1. Start stop signal

There are three kinds of start stop signal sources of frequency converter, which are panel start stop, terminal start stop and communication start stop. They are selected by function parameter P0-02.

#### 3-3-1-1. Panel start stop

The key on the panel is used for command control, and the run key on the keyboard is pressed to start the operation of the frequency converter; while the frequency converter is running, the stop key on the keyboard is pressed to stop the operation of the frequency converter.

Parameter	Name	Setting value	Note
P0-02	Operation command channel	0	Operation panel command

#### 3-3-1-2. Terminal start stop

VH5 inverter provides a variety of terminal control modes. The switch signal mode is determined by function code P2-10, and the input port of start stop control signal is determined by function code P2-00 ~ P2-09.

Example 1: Two-wire control, forward signal connected to X1, reverse signal connected to X2.

Parameter	Name	Setting value	Note
P0-02	operation command channel	1	Terminal command
P2-10	XI terminal command	0	Two-wire mode 1

	mode		
P2-00	X1 function selection	1	Forward run
P2-01	X2 function selection	2	Reverse run

Example 2: 3-wire control, forward signal connected to X1, reverse signal connected to X2, stop signal connected to X3.

Parameter	Name	Setting value	Note
P0-02	operation command channel	1	Terminal command
P2-10	XI terminal command mode	2	3-wire mode 1
P2-00	X1 function selection	1	Forward run
P2-01	X2 function selection	2	Reverse run
P2-02	X3 function selection	3	3-wire mode run

### 3-3-1-3. Communication start stop

VH5 supports Modbus-RTU mode to communicate with the host computer. The built-in communication port of frequency converter is Modbus-RTU slave protocol, and the host computer must use Modbus-RTU master protocol to communicate with it.

Example of communication parameter setting:

Parameter	Name	Setting value	Note
P0-02	operation command channel	2	Communication command
P9-00	Communication protocol selection	0	Modbus-RTU
P9-01	Local address	1	Station number 1
P9-02	Baud rate	6	19200BPS
P9-03	Data format	1	8-E-1

## 3-3-2. Start mode

There are three starting modes of frequency converter, which are direct starting, speed tracking restart and asynchronous machine pre-excitation starting. They are selected by function parameter P4-00.

### 3-3-2-1. Direct start

Parameter	Name	Setting value	Note
P4-00	Starting mode	0	Direct start mode is applicable to most small inertia loads. The frequency curve of start-up process is shown in the following figure. The "DC braking" function before startup is applicable to the driving of elevator and heavy load; the starting frequency is applicable to the equipment which needs to impact start, such as cement mixer equipment.

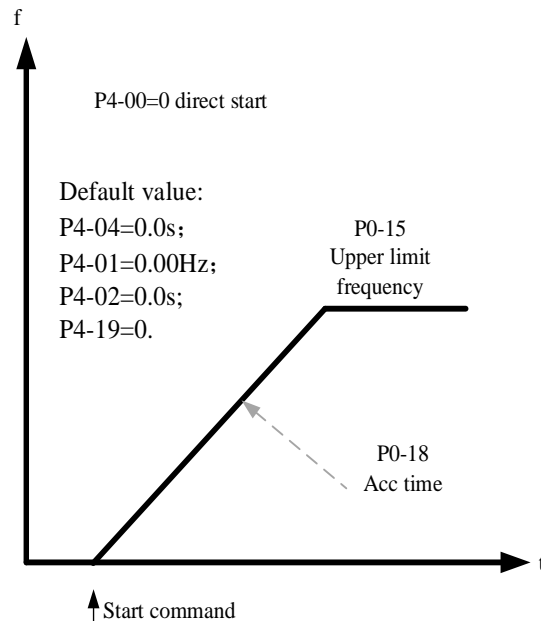
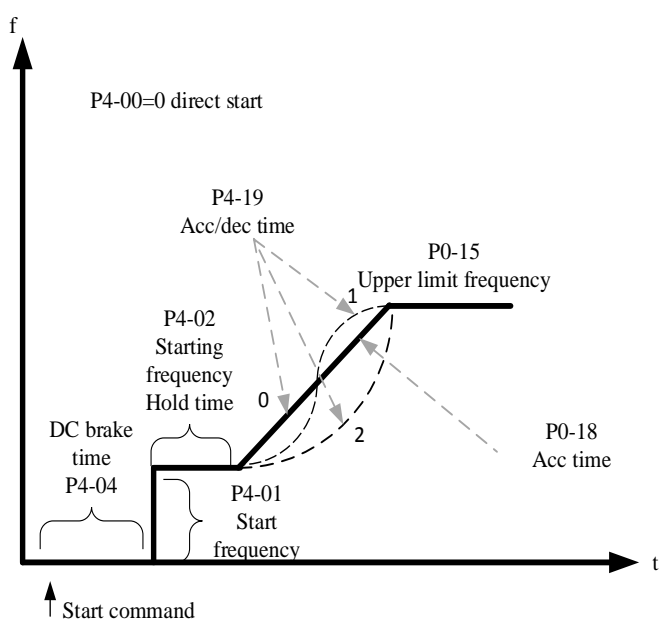

### 3-3-2-2. Speed tracking restart

Parameter	Name	Setting value	Note
P4-00	Start mode	1	Speed tracking restart mode is applicable to the large inertia mechanical load. The frequency curve of starting process is shown in the following figure. If the load motor is still running on inertia when the frequency converter is started, the speed tracking and restart can avoid the over-current.

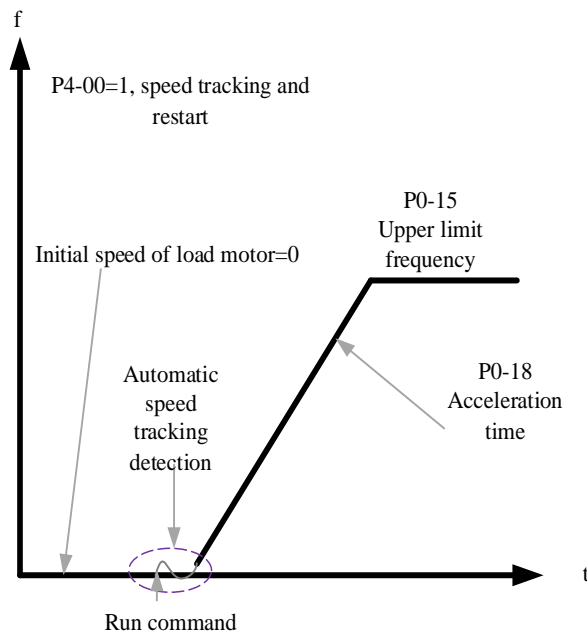
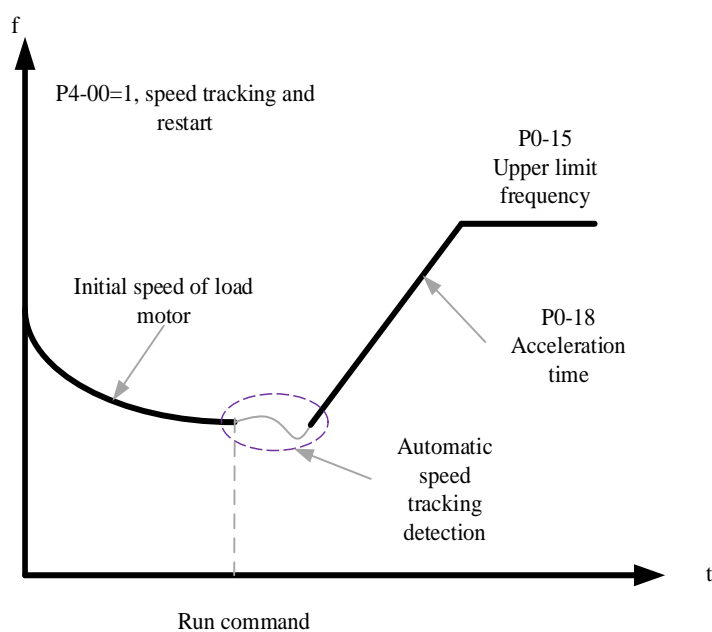

### 3-3-2-3. Pre-excitation start

Parameter	Name	Setting value	Note
P4-00	Start mode	2	Pre-excitation starting mode is only suitable for asynchronous motor load. Pre-excitation before starting can improve the fast response characteristics of induction motor and meet the application requirements of short acceleration time.

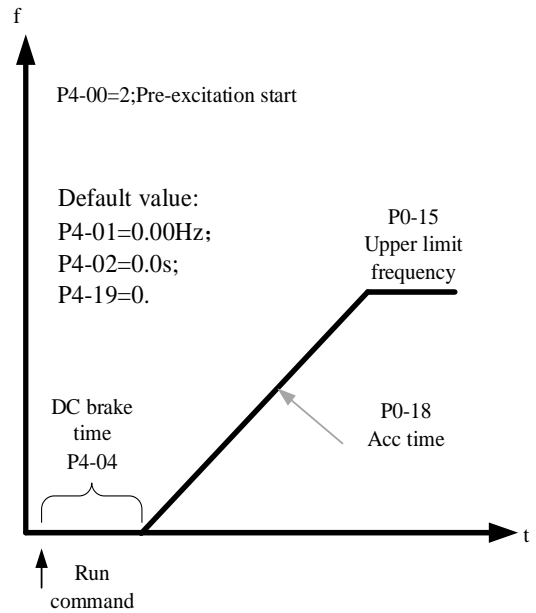
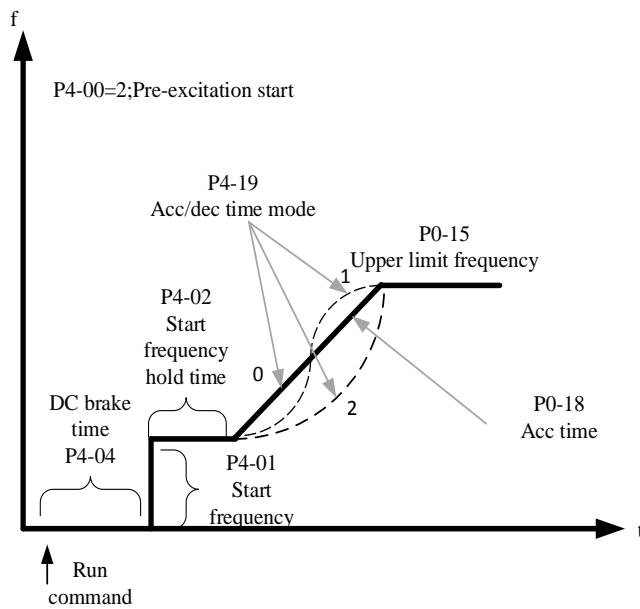

### 3-3-3. Stop mode

There are two stop modes of frequency converter, namely deceleration stop and free stop, which are selected by function code P4-22.

Parameter	Name	Setting value	Note
P4-22	Stop mode	0	The frequency converter stops according to the deceleration time
		1	Free stop, inverter stop output immediately, motor stop freely by inertia

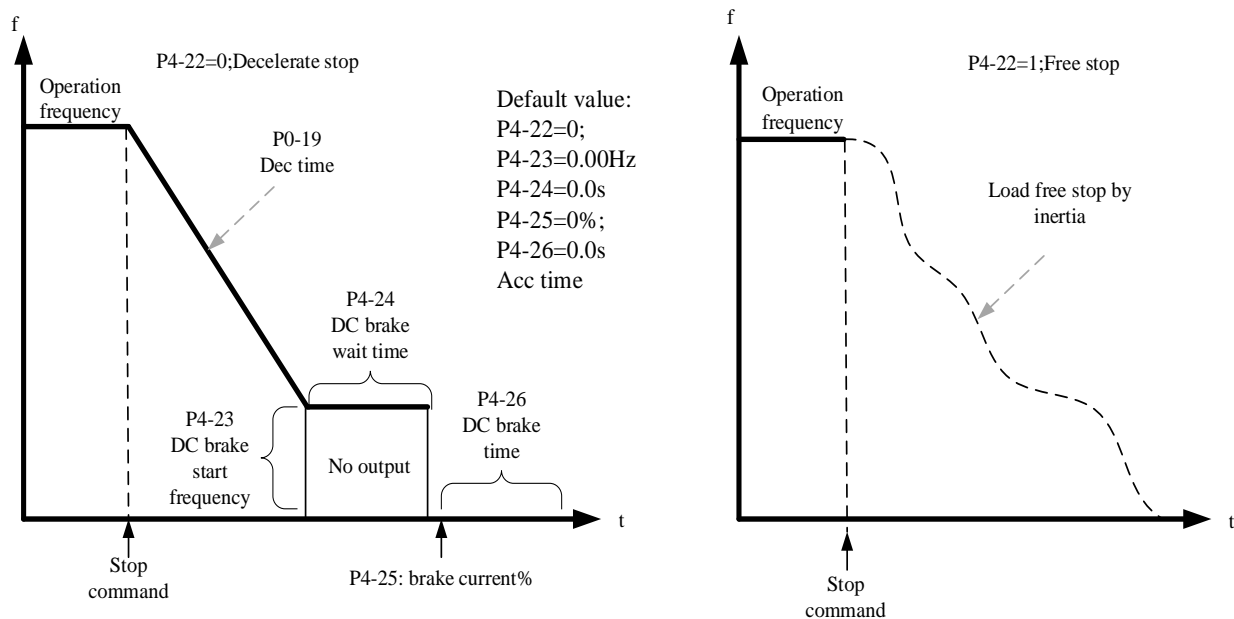

### 3-4. VFD operation frequency

The frequency converter is equipped with two frequency setting channels, named as main frequency source A and auxiliary frequency source B, which can work in a single channel or switch at any time, or even set calculation method for combination, so as to meet the different control requirements of the application site.

Set through function code P0-05

Parameter	Range	Note
P0-05	Ones bit (0~2)	0: main frequency source A 1: main frequency source operation result 2: switch between main frequency source A and auxiliary frequency source B
	Tens bit (0~3)	0: A+B 1: A-B 2: larger one of A and B 3: smaller one of A and B

### 3-5. Swing frequency function

The swing frequency function refers to the frequency output of the frequency converter, which swings up and down with the set frequency as the center. In the textile and chemical fiber processing equipment, the frequency swing function can improve the evenness of the spindle winding. The relevant parameters are as follows:

Parameter	Name	Range
A0-05	Swing frequency setting mode	0: relative to center frequency 1: relative to the max frequency
A0-06	Swing frequency amplitude	0.0% ~ 100.0%
A0-07	Jump frequency amplitude	0.0% ~ 50.0%
A0-08	Swing frequency period	0.1s ~ 3600.0s
A0-09	Triangular rise time of swing frequency	0.1% ~ 100.0%

The reference value of swing amplitude is determined by parameter A0-05.

0: relative to the center frequency (P0-05 frequency source), variable swing system. The swing varies with the center frequency (set frequency).

1: relative to the maximum frequency (P0-13) is a fixed swing amplitude system.

When the swing frequency is relative to the center frequency (A0-05 = 0), the trajectory on the time axis is shown as follows:

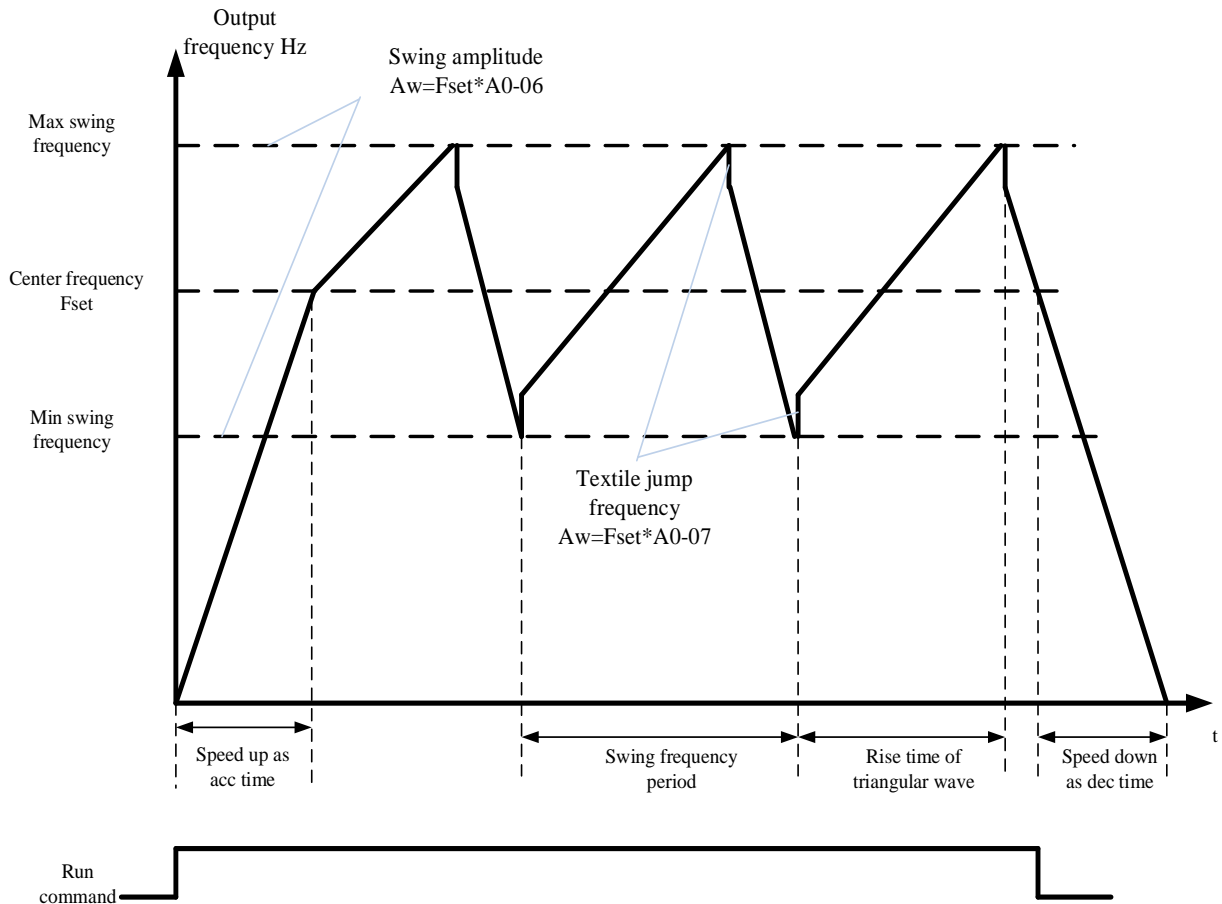

A0-06 swing amplitude AW:

When swing amplitude is relative to the center frequency (A0-05=0),  $AW = \text{frequency source P0-05} \times A0-06$ ;

When swing amplitude is relative to the max frequency (A0-05=1),  $AW = \text{max frequency P0-06} \times A0-06$ .

A0-08 swing frequency period: time value of a complete frequency swing period.

A0-07 Jump frequency amplitude:

The jump frequency amplitude is the percentage of the jump frequency relative to the swing amplitude when the swing frequency is running, that is, the jump frequency = swing amplitude AW  $\times$  jump frequency amplitude A0-07.

If the swing is relative to the center frequency (A0-05=0), the jump frequency is the variable value. If the swing is relative to the maximum frequency (A0-05=1), the jump frequency is a fixed value. The swing operating frequency is constrained by the upper and lower limit frequencies.

A0-09 triangle wave rise time coefficient: it is the time percentage of triangle wave rise time relative to frequency swing period A0-08.

triangle wave rise time (s) = swing frequency period A0-08  $\times$  A0-09;

triangle wave fall time (s) = swing frequency period A0-08  $\times$  (1 - A0-09).

## 3-6. Motor parameters and tuning

### 3-6-1. Motor parameter setting

When the inverter operates in vector control (P0-01 = 1 or 2) mode, it is required to set correct motor parameters, which is different from VF (P0-01 = 0) mode.

Motor parameters 1	Description	Note
P1-01~P1-05	Motor rated power / voltage / current / frequency / speed	Model parameters, manual input
P1-06~P1-10	Equivalent stator resistance, inductance and rotor inductance of the motor	Tuning parameters, tuning obtained

Motor parameters 2 for multi-motor system

Motor parameters 1	Description	Note
PA-01~PA-05	Motor rated power / voltage / current / frequency / speed	Model parameters, manual input
PA-06~PA-10	Equivalent stator resistance, inductance and rotor inductance of the motor	Tuning parameters, tuning obtained

### 3-6-2. Motor tuning

The methods to get the internal electrical parameters of the controlled motor are: dynamic tuning, static tuning, manual input of motor parameters and so on.

Tuning mode	Suitable condition	Effect
No load dynamic tuning	It is suitable for asynchronous motor. The situation where the motor and application system are easy to separate.	Best
With load dynamic tuning	It is suitable for asynchronous motor. The situation where the motor and application system are not easy to separate	General
Static tuning	It is only suitable for asynchronous motor, where motor and load are difficult to separate and dynamic tuning operation is not allowed, P1-09 and P1-10 are not tuned.	Better
Manual input parameters	For asynchronous motors only. When it is difficult to separate the motor from the application system, copy the motor parameters of the same model that have been successfully tuned by the frequency converter to the corresponding function codes of P1-00 ~ P1-10.	General

The automatic tuning procedure of motor parameters is as follows:

The following is an example of parameter tuning method of default motor 1. The tuning method of motor 2 is the same as that, but the function code number should be changed accordingly.

Step 1: if the motor can be completely disconnected from the load, in case of power failure, the motor is separated from the load part mechanically, so that the motor can rotate freely without load.

Step 2: after power on, select the first motor control mode (P0-01) as open-loop vector, and then select the command source of frequency converter (P0-02) as the operation panel.

Step 3: input the nameplate parameters of the motor accurately (for example P1-00 ~ P1-05), please input the following parameters according to the actual parameters of the motor (select according to the current motor):

Motor selection	Parameter
Motor 1	P1-00: motor type P1-01: motor rated power P1-02: motor rated voltage P1-03: motor rated current P1-04: motor rated frequency P1-05: motor rated speed
Motor 2	PA-00~PA-05: same to above definitions

Step 4: if it is an asynchronous motor, P1-35 (tuning selection, motor 2 corresponds to PA-35) please select 2 (dynamic tuning of asynchronous motor), press ENT to confirm, at this time, the keyboard displays TUNE.

Then press the RUN key on the keyboard panel, the frequency converter will drive the motor to accelerate and decelerate, forward and reverse operation, the operation indicator will light up, and the tuning operation lasts for about 2 minutes. When the above display information disappears, it will return to the normal parameter display state, indicating that the tuning is completed.

After the dynamic tuning, the inverter will automatically calculate the following parameters of the motor:

Motor selection	Parameter
Motor 1	P1-06: Asynchronous motor stator resistance P1-07: Asynchronous motor rotor resistance P1-08: Asynchronous motor leakage inductance P1-09: Asynchronous motor interaction inductive reactance P1-10: Asynchronous motor no load current
Motor 2	PA-06~PA-10: same to above definition

If the motor cannot be completely disconnected from the load, select 1 (static tuning of the asynchronous machine) in P1-35 (motor 2 is PA-35), and then press run on the keyboard panel to start the tuning operation of motor parameters.

### 3-7. Using method of terminal X

When out of factory, P2-16 = 0000, P2-17 = 0000. When X is short circuited, the signal is valid (logic 1); when X terminal is suspended, the signal is invalid (logic 0);

The user can also change the effective mode of the X terminal, that is, when the X terminal is short circuited, it is an invalid (logic 0) signal; when the X terminal is suspended, it is an effective (logic 1) signal. At this time, the corresponding bits of P2-16 and P2-17 need to be changed to 1.

The frequency converter also has software filtering time (P2-12) for the input signal X, which can improve the anti-interference level.

For the X1-X3 input, the port signal delay function is specially provided to facilitate some applications requiring delay processing.

The functions of the above four X terminals can be defined in P2-00 ~ P2-03, and each X can be selected from 51 functions as required. Refer to the detailed description of P2-00 ~ P2-03 for details.

### 3-10. Using method of terminal Y

VH5 VFD has two channels of output, which are Y1 and TA/TB/TC, wherein Y1 is transistor output, which can drive 24VDC low-voltage signal circuit, TA/TB/TC is relay output, and can drive 220VAC control circuit and DC24V control circuit.

By setting the value of P3-01 to P3-05, output function of each channel can be defined. It can be used to indicate various working states and alarms of the inverter. There are about 40 function settings in total, so that the user can realize specific automatic control requirements. Please refer to the detailed description of group P3



---

parameters.

### 3-9. Using method of terminal AI

VH5 supports 1 channel of AI terminal.

Terminal	Input signal
AI1-GND	Voltage 0~10V Current 0~20mA

AI can be used when using external voltage and current signal to set frequency, torque, voltage of VF separated, PID or feedback. The voltage or current value corresponding to the actual given or feedback physical quantity relationship is set through P2-18 ~ P2-45.

The sampling value of AI can be read in U group function code; the converted calculation value is used for internal subsequent calculation, and users cannot read it directly.

### 3-10. Using method of terminal AO

VH5 supports one channel AO output.

Terminal	Output signal
AO-GND	Voltage 0~10V Current 0~20mA

AO can be used to indicate the internal operation parameters in analog mode. The indicated parameter attributes can be modified through P3-13 before output. The modified characteristic curve  $Y = kX + b$ , where  $x$  is the operation parameter to be output, and the  $k$  and  $b$  of AO can be set by function codes P3-15 and P3-16.

# 4. Function parameters

## 4-1. Function code list

‘○’: Parameters can be modified during operation.

‘×’: Parameters cannot be modified during operation.

‘—’: Read only, user cannot change.

Group P0: basic operation parameters

Group P0: basic operation parameters				
Parameter	Name	Setting range	Default value	Modify
P0-01	First motor control mode	0: VF control mode 1: No speed sensor vector control (SVC)	0	×
P0-02	Command source	0: Operation panel 1: Terminal operation 2: Serial port	0	○
P0-03	Main frequency source A selection	0: Digital setting (no memory when power off) 1: Digital setting (power down memory) 3: AI 6: MODBUS RTU setting 7: Multi-segment command setting 8: PID setting 9: Simple PLC operation	0	×
P0-04	Auxiliary frequency source B selection	0: Digital setting (no memory when power off) 1: Digital setting (power down memory) 3: AI 6: Communication setting 7: Multi-segment command setting 8: PID setting 9: Simple PLC operation	0	×
P0-05	Frequency source superposition selection	Ones bit: frequency source selection 0: Main frequency source A 1: Calculation results of main and auxiliary frequency sources 2: Switching between main frequency source A and auxiliary frequency source B Tens bit: the operation relationship of main and auxiliary frequency sources 0: A+B 1: A-B 2: max (A, B) 3: min (A, B)	00	○
P0-06	Auxiliary frequency source B range selection	0: Relative to the maximum frequency 1: Relative to the main frequency source A	0	○
P0-07	Auxiliary frequency source B	0%~150%	100%	○

Group P0: basic operation parameters				
Parameter	Name	Setting range	Default value	Modify
	range			
P0-09	Digital setting of auxiliary frequency source offset	0.00Hz~max frequency P0-13	0.00Hz	○
P0-10	Preset frequency	0.00Hz~max frequency P0-13	50Hz	○
P0-12	Digital setting frequency memory selection	0: Not memory 1: Memory	0	○
P0-13	Maximum output frequency	50.00Hz~500.00Hz	50.00Hz	×
P0-14	Upper limit frequency source	0: Set by p0-15 2: AI setting 5: Communication setting	0	×
P0-15	Upper limit frequency	Lower limit frequency P0-17~Max output frequency P0-13	50.00Hz	○
P0-16	Upper limit frequency offset	0.00Hz~ Max output frequency (P0-13)	0.00Hz	○
P0-17	Lower limit frequency	0.00Hz~ Upper limit frequency P0-15	0.00Hz	○
P0-18	Acceleration time 1	0~65000 (PC-09=0) 0.0~6500.0 (PC-09=1) 0.00~650.00 (PC-09=2)	Model setting	○
P0-19	Deceleration time 1	0~65000 (PC-09=0) 0.0~6500.0 (PC-09=1) 0.00~650.00 (PC-09=2)	Model setting	○
P0-20	Operation direction	0: Running in the default direction 1: Run in the opposite direction from the default	0	○
P0-21	Reverse operation	0: Allow reverse 1: Reverse is prohibited	0	○
P0-22	Dead time of forward and reverse rotation	0.0s~3600.0s	0.0s	○
P0-23	Run time frequency command up/down reference	0: Operating frequency 1: Set frequency	0	×
P0-25	Motor parameter group selection	0: Motor parameter group 1 1: Motor parameter group 2	0	×

Group P1: first motor parameters

Group P1: first motor parameters				
Parameter	Name	Setting range	Default value	Modify
P1-00	Motor type selection	0: Common asynchronous motor	0	×
P1-01	Motor rated power	0.1kW~650.0kW	Model setting	×
P1-02	Motor rated voltage	1V~1200V	Model setting	×
P1-03	Motor rated current	0.01A~655.35A (VFD power ≤55kW)	Model	×

Group P1: first motor parameters				
Parameter	Name	Setting range	Default value	Modify
		0.1A~6553.5A (VFD power >55kW)	setting	
P1-04	Motor rated frequency	0.01Hz~ max output frequency	Model setting	×
P1-05	Motor rated speed	1rpm~65535rpm	Model setting	×
P1-06	Asynchronous motor stator resistance	0.001Ω~65.535Ω (VFD power ≤55kW) 0.0001Ω~6.5535Ω (VFD power >55kW)	Tuning parameter	×
P1-07	Asynchronous motor rotor resistance	0.001Ω~65.535Ω (VFD power ≤55kW) 0.0001Ω~6.5535Ω (VFD power >55kW)	Tuning parameter	×
P1-08	Leakage inductance of induction motor	0.01mH~655.35mH (VFD power ≤55kW) 0.001mH~65.535mH (VFD power >55kW)	Tuning parameter	×
P1-09	Mutual inductance of induction motor	0.01mH~655.35mH (VFD power ≤55kW) 0.001mH~65.535mH (VFD power >55kW)	Tuning parameter	×
P1-10	No load current of asynchronous motor	0.01A~P1-03 (VFD power ≤55kW) 0.1A~P1-03 (VFD power >55kW)	Tuning parameter	×
P1-35	Self learning of motor parameters	0: No operation 1: Static self learning of asynchronous motor (part of parameters) 2: Asynchronous motor rotation self-learning	0	×

Group P2: Input terminal function parameters

Group P2: Input terminal function parameters				
Parameter	Name	Setting range	Default value	Modify
P2-00	Input terminal X1 function selection	0: no function 1: FWD or run command 2: REV or fwd/rev direction (Note: when it is set to 1 or 2, it should be used with P2-10. See the parameter for details) 3: three wire mode operation 4: forward jog (FJOG) 5: reverse jog (RJOG) 6: terminal UP 7: terminal DOWN 8: UP/DOWN setting clear 9: free stop 10: fault reset 11: frequency source switching 12: multi-segment command terminal 1 13: multi-segment command terminal 2 14: multi-segment command terminal 3 15: multi-segment command terminal 4 16: acc/dec time terminal 1	01	×
P2-01	Input terminal X2 function selection		02	×
P2-02	Input terminal X3 function selection		10	×
P2-03	Input terminal X4 function selection		00	×

Group P2: Input terminal function parameters				
Parameter	Name	Setting range	Default value	Modify
		17: acc/dec time terminal 2 18: acc/dec prohibited 24: swing frequency pause 25: operation pause 26: PLC status reset 27: run command switch to keyboard 28: run command switch to communication 29: torque control prohibited 30: switch between speed control and torque control 32: PID pause 33: PID reverse direction of action 34: PID integral pause 35: PID parameter switching 36: external fault normally open input 37: external fault normally close input 38: user-defined fault 1 39: user-defined fault 2 40: motor parameter selection 41: switch between main frequency X and preset frequency 42: switch between auxiliary frequency Y and preset frequency 43: frequency setting effective terminal 44: DC braking 45: deceleration DC braking 46: emergency stop 47: external stop terminal (only valid for panel control) 48: external terminal stop (according to deceleration time 4) 49: reverse run prohibited 50: the running time is cleared 51: two wire / three wire switching		
P2-10	XI terminal command mode	0: two wire mode 1 1: two wire mode 2 2: three wire mode 1 3: three wire mode 2	0	×
P2-11	XI terminal UP/DOWN changing rate	0.001Hz/s~50Hz/s	1.00Hz/s	○
P2-12	XI terminal filtering time	0.000s~1.000s	0.010s	○
P2-13	X1 delay time	0.0s~3600.0s	0.0s	×
P2-14	X2 delay time	0.0s~3600.0s	0.0s	×
P2-15	X3 delay time	0.0s~3600.0s	0.0s	×
P2-16	XI terminal effective state selection 1	0: high level valid 1: Low level effective	00000	×

Group P2: Input terminal function parameters				
Parameter	Name	Setting range	Default value	Modify
		Ones bit: X1 Tens bit: X2 Hundreds bit: X3 Thousands bit: X4		
P2-18	AI curve 1 min setting	0.00V~P2-20	0.00V	○
P2-19	AI curve 1 min setting corresponding frequency percentage	-100.0%~+100.0%	0.0%	○
P2-20	AI curve 1 max setting	P2-18~+10.00V	10.00V	○
P2-21	AI curve 1 max setting corresponding frequency percentage	-100.0%~+100.0%	100.0%	○
P2-22	AI curve 2 min setting	0.00V~P2-24	0.00V	○
P2-23	AI curve 2 min setting corresponding frequency percentage	-100.0%~+100.0%	0.0%	○
P2-24	AI curve 2 max setting	P2-22~+10.00V	10.00V	○
P2-25	AI curve 2 max setting corresponding frequency percentage	-100.0%~+100.0%	100.0%	○
P2-26	AI curve 3 min setting	0.00V~P2-28	0V	○
P2-27	AI curve 3 min setting corresponding frequency percentage	-100.0%~+100.0%	0.0%	○
P2-28	AI curve 3 max setting	P2-26~+10.00V	10.00V	○
P2-29	AI curve 3 max setting corresponding frequency percentage	-100.0%~+100.0%	100.0%	○
P2-30	AI curve 4 min setting	0.00V~P2-32	0.00V	○
P2-31	AI curve 4 min setting corresponding frequency percentage	-100.0%~+100.0%	0.0%	○
P2-32	AI curve 4 inflection point 1 setting	P2-30~P2-34	10.00V	○
P2-33	AI curve 4 inflection point 1 setting corresponding frequency percentage	-100.0%~+100.0%	100.0%	○
P2-34	AI curve 4 inflection point 2 setting	0.00V~P2-36	0.00V	○
P2-35	AI curve 4 inflection point 2 setting corresponding frequency percentage	-100.0%~+100.0%	0.0%	○
P2-36	AI curve 4 max setting	P2-34~+10.00V	10.00V	○

Group P2: Input terminal function parameters				
Parameter	Name	Setting range	Default value	Modify
P2-37	AI curve 4 max setting corresponding frequency percentage	-100.0%~+100.0%	100.0%	○
P2-38	AI curve 5 min setting	-10.00V~P2-40	0V	○
P2-39	AI curve 5 min setting corresponding frequency percentage	-100.0%~+100.0%	0.0%	○
P2-40	AI curve 5 inflection point 1 setting	P2-38~P2-42	10.00V	○
P2-41	AI curve 5 inflection point 1 setting corresponding frequency percentage	-100.0%~+100.0%	100.0%	○
P2-42	AI curve 5 inflection point 2 setting	P2-40~P2-44	0.00V	○
P2-43	AI curve 5 inflection point 2 setting corresponding frequency percentage	-100.0%~+100.0%	0.0%	○
P2-44	AI curve 5 max setting	P2-42~+10.00V	10.00V	○
P2-45	AI curve 5 max setting corresponding frequency percentage	-100.0%~+100.0%	100.0%	○
P2-54	AI curve selection	Tens bit: AI curve selection 1: Curve 1 (2 points, see P2-18 ~ P2-21) 2: Curve 2 (2 points, see P2-22 ~ P2-25) 3: Curve 3 (2 points, see P2-26 ~ P2-29) 4: Curve 4 (4 points, see P2-30 ~ P2-37) 5: Curve 5 (4 points, see P2-38 ~ P2-45)	321	○
P2-55	AI below minimum input setting selection	Ones bit: AI below minimum input setting selection 0: Corresponding minimum input setting 1: 0.0%	000	○
P2-56	AI filter time constant	0.00s~10.00s	0.10s	○
P2-62	AI jump point	-100.0%~+100.0%	0.0%	○
P2-63	AI jump range	0.0%~100.0%	0.5%	○

Group P3: output terminal function parameters

Group P3: output terminal function parameters				
Parameter	Name	Setting range	Default value	Modify
P3-01	Y1 output function selection	0: No output 1: Inverter in operation 2: Fault output (free stop fault) 3: Frequency level detection FDT1 output 4: Frequency level detection FDT2 output 5: Frequency arrival 6: Zero speed operation (no output during shutdown) 7: Zero speed operation 2 (output when shutdown) 8: Upper limit frequency arrival 9: Lower limit frequency arrival (operation related)	01	○
P3-04	Relay 1 output function selection	10: Motor overload alarm 11: Frequency converter overload alarm 12: Communication settings 13: In torque limit 15: Frequency 1 reached output 16: Frequency 2 reached output 17: Current 1 reached output 18: Current 2 reached output 20: Specified counting value reached 21: Ready for operation 23: AI1 input overrange 24: Under voltage state output 25: Cumulative power on time reached 26: Timing arrival output	02	○
P3-05	Relay 2 output function selection	28: Simple PLC cycle completed 29: Cumulative running time arrival 32: Lower limit frequency reached (output when shutdown) 33: Fault output (free stop fault and no output under voltage) 34: module temperature reached 35: warning output (all faults) 37: in reverse operation 39: output current overrange 40: zero current state 41: this time of running time arrived 42: bus voltage arrived	00	○
P3-06	Y1 output delay time	0.0s~3600.0s	0.0s	○
P3-09	Relay 1 output delay time	0.0s~3600.0s	0.0s	○
P3-11	Y terminal effective state selection	0: positive logic 1: negative logic Ones bit: Y1 Thousands bit: relay 1	00000	○



Group P3: output terminal function parameters				
Parameter	Name	Setting range	Default value	Modify
P3-13	AO output selection	0: Operating frequency 1: Set frequency 2: Output current 3: Motor output torque (absolute value, percentage relative to motor) 4: Output power 5: Output voltage 7: AI 10: Output speed 12: Communication control output	00	○
P3-15	AO zero bias coefficient	-100.0%~+100.0%	0.0%	○
P3-16	AO gain	-10.00~+10.00	1.00	○

Group P4: start stop mode

Group P4: start stop mode				
Parameter	Name	Setting range	Default value	Modify
P4-00	Starting mode	0: direct start 1: Speed tracking restart 2: Pre-excitation starting (AC asynchronous motor)	0	○
P4-01	Starting frequency	0.00Hz~10.00Hz	0.00Hz	○
P4-02	Start frequency duration	0.0s~100.0s	0.0s	×
P4-03	Percentage of starting DC braking current and pre-excitation current	0%~100%	0%	×
P4-04	DC braking time / pre-excitation time at start-up	0.0s~100.0s	0.0s	×
P4-05	Start protection selection	0: No protection 1: Protection	0	×
P4-06	Speed tracking mode	0: Start from shutdown frequency 1: Starting from power frequency 2: Start at maximum output frequency	0	×
P4-07	Speed tracking speed	1~100	20	○
P4-10	Speed tracking closed loop current	30%~200%	Model confirmed	×
P4-19	Acceleration and deceleration mode	0: linear acceleration and deceleration 1: Continuous S-curve acceleration and deceleration 2: Intermittent S-curve acceleration and deceleration	0	×
P4-20	Time proportion at the beginning of the S curve	0.0%~ (100.0% - P2-21)	30.0%	×
P4-21	Time proportion at the end of the S	0.0%~ (100.0% - P2-20)	30.0%	×

	curve			
P4-22	Stop mode	0: Deceleration stop 1: Free stop	0	○
P4-23	Starting frequency of DC braking during shutdown	0.00Hz~P0-13	0.00Hz	○
P4-24	DC braking time during shutdown	0.0s~100.0s	0.0s	○
P4-25	Percentage of DC braking current when shutdown	0%~100%	0%	○
P4-26	Waiting time of DC braking during shutdown	0.0s~100.0s	0.0s	○

Group P5: VF parameters

Group P5: VF parameters				
Parameter	Name	Setting range	Default value	Modify
P5-00	VF curve selection	0: Linear VF 1: Multipoint VF 2: Square VF 3: the 1.2nd power VF 4: the 1.4th power VF 6: the 1.6th power VF 8: the 1.8th power VF 10: VF complete separation mode 11: VF semi separation mode	00	×
P5-01	Multipoint VF frequency point F1	0.00Hz~P5-03	0.00Hz	×
P5-02	Multipoint VF voltage point V1	0.0~100.0%	0.0%	×
P5-03	Multipoint VF frequency point F2	P5-01~P5-05	0.00Hz	×
P5-04	Multipoint VF voltage point V2	0.0~100.0%	0.0%	×
P5-05	Multipoint VF frequency point F3	P5-05~P1-04 (motor rated frequency)	0.00Hz	×
P5-06	Multipoint VF voltage point V3	0.0~100.0%	0.0%	×
P5-07	Torque boost	0.0% (automatical torque boost) 0.1%~30.0%	Model setting	○
P5-08	Cut-off frequency of torque boost	0.00Hz~ P0-13	50.00Hz	×
P5-09	VF separated voltage source	0: digital setting 1: AI 5: communication setting 6: multi-speed command 7: PID setting 8: simple PLC operation	0	○
P5-10	VF separated voltage source digital setting	0~motor rated voltage	0V	○
P5-11	VF separated voltage acceleration time	0.0s~1000.0s	0.0s	○
P5-12	VF separated voltage deceleration time	0.0s~1000.0s	0.0s	○
P5-13	VF separated stop mode selection	0: the frequency voltage reduced to 0	0	○

Group P5: VF parameters				
Parameter	Name	Setting range	Default value	Modify
		independently 1: When the voltage decreases to zero, the frequency begins to decrease again		
P5-14	VF slip compensation gain	0.0%~200.0%	0.0%	○
P5-15	Slip compensation time constant	0.1~10.0s	0.0%	○
P5-16	VF over excitation gain	0~200	64	○
P5-17	VF oscillation suppression gain	0~100	Model setting	○
P5-18	VF oscillation suppression mode selection	0~4	3	×
P5-19	VF over current stall action current	50~200%	150%	×
P5-20	VF over current stall suppression enable	0: invalid 1: valid	1	×
P5-21	VF over current stall suppression gain	0~100	20	○
P5-22	VF over current stall action current compensation coefficient	50%~200%	50	×
P5-23	Overvoltage stall action voltage	200.0V~2000.0V	Model setting	×
P5-24	Overvoltage stall enable	0: invalid 1: valid	1	×
P5-25	Over voltage stall suppression frequency gain	0~100	30	○
P5-26	Over voltage stall suppression voltage gain	0~100	30	○
P5-27	Limit of maximum rise frequency of over voltage stall	0~50Hz	5Hz	×

Group P6: Vector control parameters

Group P6: Vector control parameters				
Parameter	Name	Setting range	Default value	Modify
P6-00	Speed loop proportional gain 1	1~100	30	○
P6-01	Speed loop integration time 1	0.01s~10.00s	0.50s	○
P6-02	Speed loop proportional gain 2	1~100	20	○
P6-03	Speed loop integration time 2	0.01s~10.00s	1.00s	○
P6-04	Switching frequency 1	0.00~P6-05	5.00Hz	○
P6-05	Switching frequency 2	P6-04~ P0-13	10.00Hz	○
P6-06	Integral attribute of speed loop	Ones bit: integral separation 0: invalid 1: valid	0	○
P6-07	Vector slip compensation coefficient	50%~200%	100%	○

Group P6: Vector control parameters				
Parameter	Name	Setting range	Default value	Modify
P6-08	SVC speed feedback filter time	0.000s~1.000s	0.050s	○
P6-10	Speed control (drive) torque upper limit source	0: Set by P6-11 2: AI 5: communication setting	0	○
P6-11	Speed control (drive) torque upper limit digital setting	0.0%~200.0%	150.0%	○
P6-14	Proportional gain of excitation regulation	0 ~ 60000	2000	○
P6-15	Integral gain of excitation regulation	0 ~ 60000	1300	○
P6-16	Torque regulated proportional gain	0 ~ 60000	2000	○
P6-17	Integral gain of torque regulation	0 ~ 60000	1300	○

Group P7: Fault parameters

Group P7: Fault parameters				
Parameter	Name	Setting range	Default value	Modify
P7-00	Third time (last) fault type	0: No fault 1: Accelerated over current 2: Deceleration over current 3: Constant speed over current 4: Acceleration overvoltage 5: Deceleration overvoltage 6: Constant speed overvoltage 7: Buffer resistance overload fault 8: Under voltage fault 9: Inverter overload 10: Motor overload	-	-
P7-01	Second time fault type	11: Input phase loss 12: Output phase loss 13: Radiator overheating 14: Contactor fault 15: Current detection fault 16: Motor tuning fault 17: Code disk failure 18: Short circuit fault of motor to ground 19: Load drop 20: Wave by wave current limiting fault 22: UVW signal feedback error 23: Brake resistance short circuit 24: Brake pipe overload 25: Brake pipe straight through 26: SVC stall fault 43: External fault	-	-

Group P7: Fault parameters				
Parameter	Name	Setting range	Default value	Modify
P7-02	First time fault type	44: Communication failure 45: EEPROM read / write failure 46: Operation time arrival 47: Power on time arrival 48: User defined fault 1 49: User defined fault 2 50: PID feedback loss during operation 51: Running switch motor 52: Speed feedback deviation too large 53: Motor over speed 54: Motor over temperature fault 55: Point to point slave failure	-	-
P7-03	Third time (last time) fault frequency	-	-	-
P7-04	Third time (last time) fault current	-	-	-
P7-05	Third time (last time) fault bus voltage	-	-	-
P7-06	Third time (last time) fault input terminal status	-	-	-
P7-07	Third time (last time) fault output terminal status	-	-	-
P7-08	Third time (last time) fault VFD status	-	-	-
P7-09	Third time (last time) fault power on time	-	-	-
P7-10	Third time (last time) fault operation time	-	-	-
P7-13	Second time fault frequency	-	-	-
P7-14	Second time fault current	-	-	-
P7-15	Second time fault bus voltage	-	-	-
P7-16	Second time fault input terminal status	-	-	-
P7-17	Second time fault output terminal status	-	-	-
P7-18	Second time fault VFD status	-	-	-
P7-19	Second time fault power on time	-	-	-
P7-20	Second time fault operation time	-	-	-
P7-23	First time fault frequency	-	-	-
P7-24	First time fault current	-	-	-
P7-25	First time fault bus voltage	-	-	-
P7-26	First time fault input terminal status	-	-	-
P7-27	First time fault output terminal status	-	-	-
P7-28	First time fault VFD status	-	-	-
P7-29	First time fault power on time	-	-	-
P7-30	First time fault operation time	-	-	-
P7-33	Motor overload protection mode selection	0: Forbidden 1: Allow	1	○

Group P7: Fault parameters				
Parameter	Name	Setting range	Default value	Modify
P7-34	Motor overload protection gain	0.20~10.00	1.00	○
P7-35	Motor overload warning coefficient	50%~100%	80%	○
P7-39	Input phase lacking/contactor closing protection selection	Ones bit: input phase lacking protection Tens bit: contactor closing protection selection 0: Forbidden 1: Allow	11	○
P7-40	Output phase lacking protection selection	0: Forbidden 1: Allow	1	○
P7-41	Power on short circuit protection towards the ground function	0: Forbidden 1: Allow	1	○
P7-42	Action selection of fault relay during automatic fault reset	0: no action 1: action	0	○
P7-43	Interval time of automatic fault reset	0.1s~60.0s	1.0s	○
P7-44	Number of automatic reset of faults	0~20	0	○
P7-45	Protection action selection 1 when fault	Ones bit: motor overload (Err 10) 0: free stop 1: stop as stop mode Tens bit: input phase lacking (Err11) 0: free stop 1: stop as stop mode Hundreds bit: output phase lacking (Err12) 0: free stop 1: stop as stop mode Thousands bit: output load drop (Err19) 0: free stop 1: stop as stop mode Ten thousand bit: pole position detection failed (Err21) 0: free stop 1: stop as stop mode	00000	○
P7-46	Protection action selection 2 when fault	Ones bit: external fault 1 (Err43) 0: free stop 1: stop as stop mode Tens bit: communication error (Err44) 0: free stop 1: stop as stop mode Hundreds bit: EEPROM read write error (Err45)	00000	○

Group P7: Fault parameters				
Parameter	Name	Setting range	Default value	Modify
		0: free stop 1: stop as stop mode Thousands bit: operation time reached (Err46) 0: free stop 1: stop as stop mode Ten thousand bit: power on time reached (Err47) 0: free stop 1: stop as stop mode		
P7-47	Protection action selection 3 when fault	Ones bit: user defined fault 1 (Err48) 0: free stop 1: stop as stop mode Tens bit: user defined fault 2 (Err49) 0: free stop 1: stop as stop mode Hundreds bit: PID feedback lost in operation (Err50) 0: free stop 1: stop as stop mode Thousands bit: speed deviation too large (Err52) 0: free stop 1: stop as stop mode Ten thousand bit: motor over speed (Err53) 0: free stop 1: stop as stop mode	00	○
P7-48	Protection action selection 4 when fault	Ones bit: motor overheat (Err54) 0: free stop 1: stop as stop mode	00	○
P7-52	Brake starting voltage	200.0V ~ 2000.0V	690V	○
P7-53	Utilization rate of brake resistor	0 ~ 100%	100%	○
P7-55	Over voltage stall gain	0 ~ 100	30	○
P7-56	Overvoltage stall protection voltage	650V ~ 800V	760.0V	○
P7-61	Load loss detection level	0.0%~100.0%	20.0%	○
P7-62	Load loss detection time	0.0~60.0s	1.0s	○
P7-63	Over speed detection value	0.0% ~ 50.0% (the unit is max output frequency P0-13)	20.0%	○
P7-64	Over speed detection time	0.0s~60.0s	1.0s	○
P7-65	Detection value of excessive speed deviation	0.0% ~ 50.0%(unit is max frequency P0-13)	20.0%	○
P7-66	Excessive speed deviation detection time	0.0s ~ 60.0s	5.0s	○

Group P7: Fault parameters				
Parameter	Name	Setting range	Default value	Modify
P7-67	Selection of instantaneous stop non-stop function	0: Transient power failure invalid 1: Deceleration in case of instantaneous power failure 2: Deceleration stop in case of instantaneous power failure	0	×
P7-68	Pause judgement voltage of transient stop action	80.0%~100.0%	85.0%	×
P7-69	Judgment time of instantaneous stop non-stop voltage rising	0.0s~30.0s	0.5s	×
P7-70	Judgement voltage of instantaneous stop non-stop action	60.0%~100.0% (bus voltage)	80.0%	○
P7-71	Proportional gain of instantaneous stop non-stop	0 ~ 100	40	○
P7-72	Integral coefficient of instantaneous stop non-stop	0 ~ 100	30	○
P7-73	Deceleration time of instantaneous stop non-stop	0 ~ 300.0s	20.0	×

Group P8: keyboard and display

Group P8: keyboard and display				
Parameter	Name	Setting range	Default value	Modify
P8-00	JOG/REV function selection	0: Menu switching 1: Forward and reverse switching 2: Forward jog 3: Reverse jog	0	×
P8-01	STOP/REST function	0: Only in keyboard operation mode, STOP key shutdown function is effective 1: In any operation mode, the STOP key is effective	1	○
P8-02	Parameter initialization	0: no operation 01: restore factory parameters, excluding motor parameters 02: clear record information	0	×
P8-03	User password	0~65535	00000	○
P8-05	Personalized parameter mode selection	Ones bit: 0: No display 1: Display user selected parameters Tens bit: 0: No display 1: Display user modified parameters	00	×
P8-06	Read only user password	0: Modifiable	0	○



Group P8: keyboard and display				
Parameter	Name	Setting range	Default value	Modify
	(whether the parameter can be modified)	1: Not modifiable		
P8-07	LED operation display parameter 1 (low 16-bit)	The bit meaning 00: operating frequency 01: set frequency	001F	○
P8-08	LED operation display parameter 2 (high 16-bit)	02: bus voltage 03: output current 04: output voltage 05: output torque 06: output power 07: X input status 08: Y output status 09: AI1 voltage 10: AI2 voltage 14: PID setting 15: PID feedback 16: load speed display 17: feedback speed, the unit is 0.1Hz 18: actual feedback speed 19: line speed 20: PLC stage 23: main frequency A display 24: auxiliary frequency B display 25: communication setting value 27: voltage before AI correction 29: remaining running time 30: current power on time 31: current running time	0000	○
P8-09	LED stop display parameters	The bit meaning 0: set frequency 1: bus voltage 2: X input status 3: Y output status 5: AI voltage 8: PID setting 9: Load speed display 10: PLCStep	0033	○
P8-10	Accumulated running time	0h~65535h	-	-
P8-11	Cumulative power on time	0h~65535h	-	-
P8-12	Cumulative power consumption	0~65535 degree	-	-
P8-13	VFD type display	1: type G (Constant torque load model) 2: type P (Fan and water pump load model)	Model setting	-
P8-14	Product number	-	-	-

Group P8: keyboard and display				
Parameter	Name	Setting range	Default value	Modify
P8-15	Software version	-	-	-
P8-19	Inverter module radiator temperature	0.0°C~100.0°C	-	-
P8-20	Output power factor	0.00% ~ 200.0%	100.0	○

Group P9: communication parameters

Group P9: communication parameters				
Parameter	Name	Setting range	Default value	Modify
P9-00	Serial communication protocol selection	0: Modbus-RTU protocol 1: Extension card	0	×
P9-01	Local address	0: broadcast address 1 ~ 247 (Modbus valid)	1	○
P9-02	Communication baud rate	Ones bit: MODBUS 0: 300BPS 1: 600BPS 2: 1200BPS 3: 2400BPS 4: 4800BPS 5: 9600BPS 6: 19200BPS 7: 38400BPS 8: 57600BPS	6	○
P9-03	MODBUS data format	0: no parity (8-N-2) 1: even parity (8-E-1) 2: odd parity (8-O-1) 3: no parity (8-N-1) (Modbus valid)	1	○
P9-04	Communication timeout	0.0: invalid 0.1~60.0s	0.0	○
P9-05	MODBUS response delay	0~20ms (Modbus valid)	2	○
P9-06	Communication interruption detection of expansion card	0.0~60.0s	0.0s	○

Group PA: process control closed-loop parameters

Group PA: process control closed-loop parameters				
Parameter	Name	Setting range	Default value	Modify
PA-01	Setting channel selection	0: PA-05 setting 2: AI 5: communication setting 6: multi-segment command setting	0	○

Group PA: process control closed-loop parameters				
Parameter	Name	Setting range	Default value	Modify
PA-02	Feedback channel selection	1: AI 6: communication setting	0	○
PA-03	PID feedback filter time	0.00s~30.00s	0.00s	○
PA-04	PID output filter time	0.00s~30.00s	0.00s	○
PA-05	PID value setting	0.0%~100.0%	50.0%	○
PA-06	PID setting change time	0.00s~300.00s	0.00s	○
PA-07	PID reverse cut-off frequency	0.00Hz~ max output frequency	0.00Hz	○
PA-08	PID deviation limit	0.0%~100.0%	0.0%	○
PA-09	PID differential limit	0.00%~100.00%	0.10%	○
PA-10	Proportional gain P	0.0~100.0	20.0	○
PA-11	Integral time I	0.01s~10.00s	2.00s	○
PA-12	Differential time D	0.000s~10.000s	0.000s	○
PA-13	PID parameter switching condition	0: do not switch 1: Switch through X terminal 2: Switch automatically according to deviation 3: Switch automatically according to the operation frequency	0	○
PA-14	PID parameter switching deviation 1	0.0%~PA-15	20.0%	○
PA-15	PID parameter switching deviation 2	PA-14~100.0%	80.0%	○
PA-16	PID proportional gain P2	0.0~100.0	20.0	○
PA-17	PID integral time I2	0.01s~10.00s	2.00s	○
PA-18	PID differential time D2	0.000s~10.000s	0.000s	○
PA-19	PID action direction	0: positive action 1: negative action	0	○
PA-20	PID given feedback range	0~65535	1000	○
PA-21	PID maximum deviation between two outputs	0.00%~100.00%	1.00%	○
PA-22	PID minimum deviation between two outputs	0.00%~100.00%	1.00%	○
PA-23	PID initial value	0.0%~100.0%	0.0%	○
PA-24	PID initial value holding time	0.00s~600.00s	0.00s	○
PA-25	PID operation mode (whether to operate when stop)	0: Not operation when stop 1: Operation during shutdown	0	○
PA-26	PID integral attribute	Ones bit: integral separation 0: invalid 1: valid Tens bit: whether to stop integration after output to limit value 0: continue to integral 1: Stop integral	00	○

Group PA: process control closed-loop parameters				
Parameter	Name	Setting range	Default value	Modify
PA-27	PID feedback lost detection value	0.0%: not judge the feedback lost 0.1%~100.0%	0.0%	○
PA-28	PID feedback lost detection time	0.0s~30.0s	0.0s	○

Group PB: multi-speed and simple PLC operation parameters

Group PB: multi-speed and simple PLC operation parameters				
Parameter	Name	Setting range	Default value	Modify
PB-00	Multi-segment frequency 0	-100.0%~~+100.0%	0.0%	○
PB-01	Multi-segment frequency 1	-100.0%~~+100.0%	0.0%	○
PB-02	Multi-segment frequency 2	-100.0%~~+100.0%	0.0%	○
PB-03	Multi-segment frequency 3	-100.0%~~+100.0%	0.0%	○
PB-04	Multi-segment frequency 4	-100.0%~~+100.0%	0.0%	○
PB-05	Multi-segment frequency 5	-100.0%~~+100.0%	0.0%	○
PB-06	Multi-segment frequency 6	-100.0%~~+100.0%	0.0%	○
PB-07	Multi-segment frequency 7	-100.0%~~+100.0%	0.0%	○
PB-08	Multi-segment frequency 8	-100.0%~~+100.0%	0.0%	○
PB-09	Multi-segment frequency 9	-100.0%~~+100.0%	0.0%	○
PB-10	Multi-segment frequency 10	-100.0%~~+100.0%	0.0%	○
PB-11	Multi-segment frequency 11	-100.0%~~+100.0%	0.0%	○
PB-12	Multi-segment frequency 12	-100.0%~~+100.0%	0.0%	○
PB-13	Multi-segment frequency 13	-100.0%~~+100.0%	0.0%	○
PB-14	Multi-segment frequency 14	-100.0%~~+100.0%	0.0%	○
PB-15	Multi-segment frequency 15	-100.0%~~+100.0%	0.0%	○
PB-16	Multi-segment 0 command setting mode	0: PB-00 setting 2: AI 5: PID setting 6: preset frequency P0-10	0	○
PB-17	Simple PLC segment 0 operation time	0.0~6500.0s(h)	0.0s(h)	○
PB-18	Simple PLC segment 0 acc/dec time	0~3	0	○
PB-19	Simple PLC segment 1 operation time	0.0~6500.0s(h)	0.0s(h)	○
PB-20	Simple PLC segment 1 acc/dec time	0~3	0	○
PB-21	Simple PLC segment 2 operation time	0.0~6500.0s(h)	0.0s(h)	○
PB-22	Simple PLC segment 2 acc/dec time	0~3	0	○
PB-23	Simple PLC segment 3 operation time	0.0~6500.0s(h)	0.0s(h)	○
PB-24	Simple PLC segment 3 acc/dec time	0~3	0	○
PB-25	Simple PLC segment 4 operation time	0.0~6500.0s(h)	0.0s(h)	○

Group PB: multi-speed and simple PLC operation parameters				
Parameter	Name	Setting range	Default value	Modify
PB-26	Simple PLC segment 4 acc/dec time	0~3	0	○
PB-27	Simple PLC segment 5 operation time	0.0~6500.0s(h)	0.0s(h)	○
PB-28	Simple PLC segment 5 acc/dec time	0~3	0	○
PB-29	Simple PLC segment 6 operation time	0.0~6500.0s(h)	0.0s(h)	○
PB-30	Simple PLC segment 6 acc/dec time	0~3	0	○
PB-31	Simple PLC segment 7 operation time	0.0~6500.0s(h)	0.0s(h)	○
PB-32	Simple PLC segment 7 acc/dec time	0~3	0	○
PB-33	Simple PLC segment 8 operation time	0.0~6500.0s(h)	0.0s(h)	○
PB-34	Simple PLC segment 8 acc/dec time	0~3	0	○
PB-35	Simple PLC segment 9 operation time	0.0~6500.0s(h)	0.0s(h)	○
PB-36	Simple PLC segment 9 acc/dec time	0~3	0	○
PB-37	Simple PLC segment 10 operation time	0.0~6500.0s(h)	0.0s(h)	○
PB-38	Simple PLC segment 10 acc/dec time	0~3	0	○
PB-39	Simple PLC segment 11 operation time	0.0~6500.0s(h)	0.0s(h)	○
PB-40	Simple PLC segment 11 acc/dec time	0~3	0	○
PB-41	Simple PLC segment 12 operation time	0.0~6500.0s(h)	0.0s(h)	○
PB-42	Simple PLC segment 12 acc/dec time	0~3	0	○
PB-43	Simple PLC segment 13 operation time	0.0~6500.0s(h)	0.0s(h)	○
PB-44	Simple PLC segment 13 acc/dec time	0~3	0	○
PB-45	Simple PLC segment 14 operation time	0.0~6500.0s(h)	0.0s(h)	○
PB-46	Simple PLC segment 14 acc/dec time	0~3	0	○
PB-47	Simple PLC segment 15 operation time	0.0~6500.0s(h)	0.0s(h)	○
PB-48	Simple PLC segment 15 acc/dec time	0~3	0	○
PB-49	Simple PLC operation mode	0: stop at the end of single operation 1: Keep the final value at the end of single operation 2: cycle all the time	0	○
PB-50	Simple PLC operation time unit	0: second 1: hour	0	○
PB-51	Simple PLC power-off memory	Ones bit: power-off memory	00	○

Group PB: multi-speed and simple PLC operation parameters				
Parameter	Name	Setting range	Default value	Modify
	selection	0: not memory 1: memory Tens bit: stop memory 0: not memory 1: memory		

Group PC: auxiliary operation parameters

Group PC: auxiliary operation parameters				
Parameter	Name	Setting range	Default value	Modify
PC-00	Jog frequency	0.00Hz~max output P0-13	2.00Hz	○
PC-01	Jog acceleration time	0.0s~6500.0s	20.0s	○
PC-02	Jog deceleration time	0.0s~6500.0s	20.0s	○
PC-03	acceleration time 2	0.1s~6500.0s	Model setting	○
PC-04	deceleration time 2	0.1s~6500.0s	Model setting	○
PC-05	acceleration time 3	0.1s~6500.0s	Model setting	○
PC-06	deceleration time 3	0.1s~6500.0s	Model setting	○
PC-07	acceleration time 4	0.1s~6500.0s	Model setting	○
PC-08	deceleration time 4	0.1s~6500.0s	Model setting	○
PC-09	The unit of acc/dec time	0: 1s 1: 0.1s 2: 0.01s	1	×
PC-10	The base frequency of acc/dec time	0: max frequency 1: setting frequency 2: 50Hz	0	×
PC-11	Switching frequency point between acceleration time 1 and acceleration time 2	0.00Hz~max output frequency	0.00Hz	○
PC-12	Switching frequency point between deceleration time 1 and deceleration time 2	0.00Hz~ max output frequency	0.00Hz	○
PC-13	Jump frequency 1	0.00Hz~ max output frequency	0.00Hz	○
PC-14	Jump frequency 2	0.00Hz~ max output frequency	0.00Hz	○
PC-15	Jump frequency range	0.00Hz~ max output frequency	0.00Hz	○
PC-16	Whether the jump frequency is effective during acceleration	0: invalid 1: valid (in vector condition)	0	○

Group PC: auxiliary operation parameters				
Parameter	Name	Setting range	Default value	Modify
	and deceleration			
PC-17	Frequency reaching detection range	0.00Hz~max frequency	50.00Hz	○
PC-18	Frequency detection value (FDT1 voltage level)	0.0%~100.0%	5.0%	○
PC-19	Frequency detection hysteresis value (FDT1 voltage level)	0.0%~100.0% (max output frequency)	0.0%	○
PC-20	Frequency detection value (FDT2 voltage level)	0.00Hz~ max output frequency	50.00Hz	○
PC-21	Frequency detection hysteresis value (FDT2 voltage level)	0.0%~100.0%	5.0%	○
PC-22	Frequency reached detection value 1	0.00Hz~ max output frequency	50.00Hz	○
PC-23	Frequency reached detection 1 range	0.0%~100.0% (max output frequency)	0.0%	○
PC-24	Frequency reached detection value 2	0.00Hz~ max output frequency	50.00Hz	○
PC-25	Frequency reached detection 2 range	0.0%~100.0% (max output frequency)	0.0%	○
PC-26	Timing function selection	0: invalid 1: valid	0	×
PC-28	Setting operation time	0.0Min~6500.0Min	0.0Min	×
PC-29	Present operation reached time	0.0Min~6500.0Min	0.0Min	×
PC-30	Setting power on reached time	0 ~ 65000h	0	×
PC-32	Setting operation reached time	0 ~ 65000h	0	×
PC-34	Current reached detection value 1	0.0%~300.0% (motor rated current)	100.0%	○
PC-35	Current reached detection 1 range	0.0%~300.0% (motor rated current)	0.0%	○
PC-36	Current reached detection value 2	0.0%~300.0% (motor rated current)	100.0%	○
PC-37	Current reached detection 2 range	0.0%~300.0% (motor rated current)	0.0%	○
PC-38	Zero current detection value	0.0%~300.0% (motor rated current)	5.0%	○
PC-39	Zero current detection delay time	0.01s~600.00s	0.10s	○
PC-40	Software overcurrent point	0: 0.0% (not detect) 1: 0.1%~300.0% (motor rated current)	200.0%	○
PC-41	Software overcurrent detection delay time	0.00s~600.00s	0.00s	○
PC-42	AI1 input voltage lower limit	0.00V~PC-43	3.10V	○
PC-43	AI1 input voltage upper limit	PC-43~10.5V	6.80V	○

Group PC: auxiliary operation parameters				
Parameter	Name	Setting range	Default value	Modify
PC-44	Overvoltage point	200~810V	810V	×
PC-45	Undervoltage point	100~537V	350V	×
PC-46	Operation action when the frequency is lower than lower limit frequency	0: run at lower limit frequency 1: stop 2: run at zero speed	0	○
PC-47	Module temperature reached	0°C~100°C	75	○
PC-48	Fan control	0: The fan runs during operation 1: The fan is running all the time	0	○
PC-49	Droop control	0.00Hz~10.00Hz	0.00Hz	○
PC-50	Terminal jog run priority	0: invalid 1: valid	0	○
PC-51	SVC optimization selection	1: Optimization mode 1 2: Optimization mode 2	2	○
PC-52	Dead area compensation mode	0: No compensation 1: Compensation mode 1	1	○
PC-54	Modulation mode	0: Asynchronous Modulation 1: Synchronous modulation	0	○
PC-55	DPWM switching upper limit frequency	5.00Hz~max output frequency	8.00Hz	○
PC-56	Random PWM	0: Random PWM invalid 1~10: PWM carrier frequency random depth	0	○
PC-57	Wake up frequency	Dormancy frequency PC-58~max output frequency P0-13	0.00Hz	○
PC-58	Dormancy frequency	0.00Hz~wake up frequency PC-57	0.00Hz	○
PC-59	Wake up delay time	0.0s~6500.0s	0.0s	○
PC-60	Dormancy delay time	0.0s~6500.0s	0.0s	○
PC-61	Wave by wave current limiting enable	0: Not enable 1: Enable	1	○
PC-62	Current detection compensation	0~100	000	○
PC-65	Bus voltage reached value	Unit is 0.1V	500.0	○
PC-66	The bus voltage reached hysteresis value	Unit is 0.1V	50.0	○
PC-67	Carrier frequency	0.5K~16.0K	Model setting	○
PC-68	The carrier frequency is adjusted with temperature	0: invalid 1: valid	1	○



Group PE: user optional parameters

Group PE: user optional parameters				
Parameter	Name	Setting range	Default value	Modify
PE-00	User optional parameters 0	P0.00 ~ PF.xx A0.00 ~ A2.xx A9.00 ~ Ad.xx U0.00 ~ U0.xx U4.00 ~ U5.xx	P0.00	○
PE-01	User optional parameters 1	Same to PE-00	P0.00	○
PE-02	User optional parameters 2	Same to PE-00	P0.00	○
PE-03	User optional parameters 3	Same to PE-00	P0.00	○
PE-04	User optional parameters 4	Same to PE-00	P0.00	○
PE-05	User optional parameters 5	Same to PE-00	P0.00	○
PE-06	User optional parameters 6	Same to PE-00	P0.00	○
PE-07	User optional parameters 7	Same to PE-00	P0.00	○
PE-08	User optional parameters 8	Same to PE-00	P0.00	○
PE-09	User optional parameters 9	Same to PE-00	P0.00	○
PE-10	User optional parameters 10	Same to PE-00	P0.00	○
PE-11	User optional parameters 11	Same to PE-00	P0.00	○
PE-12	User optional parameters 12	Same to PE-00	P0.00	○
PE-13	User optional parameters 13	Same to PE-00	P0.00	○
PE-14	User optional parameters 14	Same to PE-00	P0.00	○
PE-15	User optional parameters 15	Same to PE-00	P0.00	○
PE-16	User optional parameters 16	Same to PE-00	P0.00	○
PE-17	User optional parameters 17	Same to PE-00	P0.00	○
PE-18	User optional parameters 18	Same to PE-00	P0.00	○
PE-19	User optional parameters 19	Same to PE-00	P0.00	○
PE-20	User optional parameters 20	Same to PE-00	P0.00	○
PE-21	User optional parameters 21	Same to PE-00	P0.00	○
PE-22	User optional parameters 22	Same to PE-00	P0.00	○
PE-23	User optional parameters 23	Same to PE-00	P0.00	○
PE-24	User optional parameters 24	Same to PE-00	P0.00	○
PE-25	User optional parameters 25	Same to PE-00	P0.00	○
PE-26	User optional parameters 26	Same to PE-00	P0.00	○
PE-27	User optional parameters 27	Same to PE-00	P0.00	○
PE-28	User optional parameters 28	Same to PE-00	P0.00	○
PE-29	User optional parameters 29	Same to PE-00	P0.00	○
PE-30	User optional parameters 30	Same to PE-00	P0.00	○
PE-31	User optional parameters 31	Same to PE-00	P0.00	○

Group PF: torque control

Group PF: torque control				
Parameter	Name	Setting range	Default value	Modify
PF-00	Torque control	0: speed control 1: torque control	0	×
PF-01	Upper limit source of driver torque	0: digital setting 2: AI 5: communication setting (the full scale of option 1-7 correspond to PF-02 digital setting)	0	×
PF-02	Driver torque upper limit	-200.0%~200.0%	150.0%	○
PF-03	Torque control forward direction max frequency	0.00Hz~max output frequency	50.00Hz	○
PF-04	Torque control reverse direction max frequency	0.00Hz~ max output frequency	50.00Hz	○
PF-05	Torque acceleration time	0.00s~650.00s	0.00s	○
PF-06	Torque deceleration time	0.00s~650.00s	0.00s	○

Group A0: textile

Group A0: textile				
Parameter	Name	Setting range	Default value	Modify
A0-05	Swing frequency setting mode	0: relative to center frequency 1: relative to the maximum frequency	0	○
A0-06	Swing frequency range	0.0%~100.0%	0.0%	○
A0-07	Jump frequency amplitude	0.0%~50.0%	0.0%	○
A0-08	Swing frequency period	0.1s~3600.0s	10.0s	○
A0-09	Triangular wave rise time of swing frequency	0.1%~100.0%	50.0%	○

Group A1: virtual IO

Group A1: virtual IO				
Parameter	Name	Setting range	Default value	Modify
A1-00	Function selection of virtual X1 terminal	0~51: See group P2 physical X input selection	00	×
A1-01	Function selection of virtual X2 terminal		00	×
A1-02	Function selection of virtual X3 terminal		00	×
A1-03	Function selection of virtual X4 terminal		00	×
A1-04	Function selection of virtual X5 terminal		00	×
A1-05	Virtual X terminal effective		Ones bit: virtual X1	00000

Group A1: virtual IO				
Parameter	Name	Setting range	Default value	Modify
	state source	0: the state of virtual Y1 determines whether virtual X1 is valid 1: Function code A1-06 sets whether virtual X1 is valid Tens bit: virtual X2 Hundreds bit: virtual X3 Thousands bit: virtual X4 Ten thousands bit: virtual X5		
A1-06	Virtual X terminal status setting	0: invalid 1: valid Tens bit: virtual X1 Tens bit: virtual X2 Hundreds bit: virtual X3 Thousands bit: virtual X4 Ten thousands bit: virtual X5	00000	×
A1-07	Function selection of AI terminal as X terminal	0~51	00	×
A1-10	Selection of effective mode when AI is used as X terminal	Ones bit: AI 0: high level valid 1: low level valid	000	×
A1-11	Virtual Y1 output function selection	0: connect with physical X1 inside 1~42: see group P3 physical Y output selection	00	
A1-12	Virtual Y2 output function selection	0: connect with physical X2 inside 1~42: see group P3 physical Y output selection	00	○
A1-13	Virtual Y3 output function selection	0: connect with physical X3 inside 1~42: see group P3 physical Y output selection	00	○
A1-14	Virtual Y4 output function selection	0: connect with physical X4 inside 1~42: see group P3 physical Y output selection	00	○
A1-15	Virtual Y5 output function selection	0: connect with physical X5 inside 1~42: see group P3 physical Y output selection	00	○
A1-16	Virtual Y1 output delay time	0.0s ~ 3600.0s	0.0s	○
A1-17	Virtual Y2 output delay time	0.0s ~ 3600.0s	0.0s	○
A1-18	Virtual Y3 output delay time	0.0s ~ 3600.0s	0.0s	○
A1-19	Virtual Y4 output delay time	0.0s ~ 3600.0s	0.0s	○
A1-20	Virtual Y5 output delay time	0.0s ~ 3600.0s	0.0s	○
A1-21	Virtual Y terminal effective state selection	Ones bit: virtual Y1 0: positive logic 1: negative logic	00000	○

Group A1: virtual IO				
Parameter	Name	Setting range	Default value	Modify
		Tens bit: virtual Y2 Hundreds bit: virtual Y3 Thousands bit: virtual Y4 Ten thousands bit: virtual Y5		

Group A2: second motor parameters

Group A2: second motor parameters				
Parameter	Name	Setting range	Default value	Modify
A2-00	Motor type selection	0: Common asynchronous motor	0	×
A2-01	Motor rated power	0.1kW~650.0kW	Model setting	×
A2-02	Motor rated voltage	1V~1200V	Model setting	×
A2-03	Motor rated current	0.01A~655.35A (VFD power ≤55kW) 0.1A~6553.5A (VFD power >55kW)	Model setting	×
A2-04	Motor rated frequency	0.01Hz~max output frequency	Model setting	×
A2-05	Motor rated speed	1rpm~65535rpm	Model setting	×
A2-06	Asynchronous motor stator resistance	0.001Ω~65.535Ω (VFD power ≤55kW) 0.0001Ω~6.5535Ω (VFD power >55kW)	Tuning parameters	×
A2-07	Asynchronous motor rotor resistance	0.001Ω~65.535Ω (VFD power ≤55kW) 0.0001Ω~6.5535Ω (VFD power >55kW)	Tuning parameters	×
A2-08	Leakage inductance of asynchronous motor	0.01mH~655.35mH (VFD power ≤55kW) 0.001mH~65.535mH (VFD power >55kW)	Tuning parameters	×
A2-09	asynchronous motor mutual inductance	0.01mH~655.35mH (VFD power ≤55kW) 0.001mH~65.535mH (VFD power >55kW)	Tuning parameters	×
A2-10	asynchronous motor current without load	0.01A~P1-03 (VFD power ≤55kW) 0.1A~P1-03 (VFD power >55kW)	Tuning parameters	×
A2-35	Motor 2 parameter self-learning	0: No operation 1: Static self-learning of asynchronous motor (some parameters) 2: Self-learning of asynchronous motor rotation	0	×
A2-36	Motor 2 control mode	0: VF control 1: no speed sensor vector control (SVC)	0	×
A2-37	Motor 2 acc/dec time selection	0: same to first motor 1: acceleration and deceleration time 1 2: acceleration and deceleration time 2 3: acceleration and deceleration time 3 4: acceleration and deceleration time 4	0	○

Group A2: second motor parameters				
Parameter	Name	Setting range	Default value	Modify
A2-38	Motor 2 torque boost	0.0%: Automatic torque boost 0.1%~30.0%	Model setting	○
A2-40	Motor 2 oscillation suppression gain	0~100	Model setting	○
A2-41	Speed loop proportion gain 1	1~100	30	○
A2-42	Speed loop integral time 1	0.01s~10.00s	0.50	○
A2-43	Speed loop proportion gain 2	1~100	20	○
A2-44	Speed loop integral time 2	0.01s~10.00s	1.00	○
A2-45	Switching frequency 1	0.00~A2-46	5.00	○
A2-46	Switching frequency 2	P2-45~max output frequency (P0-13)	10.00	○
A2-47	Speed loop integral property	Ones bit: integral separation 0: invalid 1: valid	0	○
A2-48	Slip gain of vector control	50%~200%	100%	○
A2-49	SVC speed feedback filter time	0.000s~1.000s	0.015	○
A2-51	Torque upper limit source under speed control mode	0: parameter setting (A2-52) 2: AI 5: communication setting Full scale of option 1-7, corresponding to A2-53 digital setting	0	○
A2-52	Digital setting of torque upper limit in speed control mode	0.0%~200.0%	150.0%	○
A2-55	Proportional gain of excitation regulation	0 ~ 60000	2000	○
A2-56	Integral gain of excitation regulation	0 ~ 60000	1300	○
A2-57	Torque regulation proportional gain	0 ~ 60000	2000	○
A2-58	Integral gain of torque regulation	0 ~ 60000	1300	○

Group AD: AIAO correction

Group AD: AIAO correction				
Parameter	Name	Setting range	Default value	Modify
AD-04	AI measured voltage 1	0.500V~4.000V	Factory calibration	○
AD-05	AI display voltage 1	0.500V~4.000V	Factory calibration	○
AD-06	AI measured voltage 2	6.000V~9.999V	Factory calibration	○

Group AD: AIAO correction				
Parameter	Name	Setting range	Default value	Modify
AD-07	AI display voltage 2	6.000V~9.999V	Factory calibration	○
AD-12	AO1 target voltage 1	0.500V~4.000V	Factory calibration	○
AD-13	AO1 measured voltage 1	0.500V~4.000V	Factory calibration	○
AD-14	AO1 target voltage 2	6.000V~9.999V	Factory calibration	○
AD-15	AO1 measured voltage 2	6.000V~9.999V	Factory calibration	○

Group U0: monitor parameters

Group U0: monitor parameters		
Parameter	Name	Min unit
U0-00	Operation frequency (Hz)	0.01Hz
U0-01	Setting frequency (Hz)	0.01Hz
U0-02	Bus voltage (V)	0.1V
U0-03	Output current (A)	0.01A
U0-04	Output voltage (V)	1V
U0-05	Output torque (%) Percentage output value of motor rated torque	0.1%
U0-06	Output power (kW)	0.1kW
U0-07	X input state	1
U0-08	Y output state	1
U0-10	AI voltage (V)/current (mA)	0.01V/0.01mA
U0-14	PID setting	1
U0-15	PID feedback	1
U0-16	Load speed display	1
U0-17	Feedback speed (Hz)	0.01Hz
U0-18	Actual feedback speed (Hz)	0.01Hz
U0-19	Line speed	1m/Min
U0-20	PLC stage	1
U0-23	Main frequency A display	0.01Hz
U0-24	Auxiliary frequency B display	0.01Hz
U0-25	Communication setting	0.01%
U0-27	AI voltage before calibration (V)/current (mA)	0.001V/0.01mA
U0-29	Remaining running time	0.1Min
U0-30	Present power on time	1Min
U0-31	Present operation time	0.1Min
U0-32	VFD state	1
U0-33	Present fault	1
U0-34	Fault information	1
U0-35	Target torque (%)	0.1%

Group U0: monitor parameters		
Parameter	Name	Min unit
U0-36	Torque upper limit	0.01%
U0-40	Motor temperature	1°C
U0-41	Power factor angle	0.1°
U0-42	Setting frequency (%)	0.01%
U0-43	Operation frequency (%)	0.01%
U0-44	VF separate target voltage	1V
U0-45	VF separate output voltage	1V
U0-46	Z signal counter	1
U0-47	Motor serial number	0: motor 1 1: motor 2
U0-48	Check any memory address value	1
U0-65	Sending value of point-to-point communication	0.01%
U0-66	Slave machine number	1
U0-67	Communication expansion card model	
U0-68	Communication expansion card version	Display range
U0-69	Communication expansion card VFD state	Bit0: in operation Bit1: operation direction Bit2: fault
U0-70	Speed of transmission DP card /0.01Hz	0.00 ~ max frequency
U0-71	Speed of transmission DP card /RPM	0-65535
U0-72	Special current display for communication card	Display range
U0-73	Communication card error status	Display range
U0-74	Motor actual output torque	-300% ~ 300%

## 4-2. Parameter explanation

### 4-2-1. Group P0 basic operation parameter

Parameter	Name	Setting range	
P0-01	First motor control mode selection	0	VF control
		1	No speed sensor vector control (SVC)

0: VF control

VF control is suitable for low-speed occasions where the control accuracy is not high, and can also be used for occasions where one inverter drives multiple motors. It is recommended to set P1-00 ~ P1-05 in VF control.

1: no speed sensor vector control (SVC)

It refers to the open-loop vector control, which can be applied to high-performance general occasions without pulse encoder, occasions requiring low-frequency large torque and high speed control accuracy, such as machine tools, centrifuges, wire drawing machines, injection molding machines, etc.

For vector control of frequency converter, only one motor can be driven by one frequency converter, so accurate parameters of controlled motor must be obtained for self tuning. See P1-35 for specific tuning method.

parameter	Name	Range	
P0-02	Operation command channel selection	0	Operate panel
		1	Terminal
		2	Serial port

0: operate panel

Controlled by the key on the operate panel.

1: terminal

Controlled by multi-function terminals.

2: serial port

Controlled by upper PC via communication.

parameter	Name	Setting	Choose setting channel
P0-03	Main frequency A input channel selection	0	Digital setting (power-off no memory)
		1	Digital setting (power-off memory)
		3	AI setting
		6	Communication setting
		7	Multi-segment command setting
		8	PID setting
		9	Simple PLC operation

0: digital setting (power-off no memory)

Set frequency in P0-10, and adjust by keyboard increase and decrease key (or up/down terminal), after power off and power on, the frequency will return to the value of P0-10.

1: digital setting (power-off memory)

After setting the frequency in P0-10, press increase, decrease key through the keyboard, or after up/down adjustment, the frequency of the inverter will return to the adjusted value after power down. This parameter setting is only used for power down, not for shutdown. The shutdown frequency memory setting can be modified in parameter P0-12.

3: AI setting



Support 0V ~ 10V voltage input. The corresponding relationship between the input voltage value of AI and the target frequency is curve 2, and the corresponding parameters are set at P2-22~P2-25. When AI is set by the frequency, voltage/current input corresponds to 100% of the setting, which refers to the percentage relative to the maximum output frequency P0-13.

6: communication setting

Set to Modbus-RTU communication, modify frequency through RS485 communication, address H1000. Write 5000 to the address, which means 50.00% of the maximum frequency. If the maximum frequency is 50 Hz, then the frequency is 25 Hz. Communication parameters can be set in group P9.

7: multi-segment command setting

The non-zero combination of input terminals correspond to different frequencies and acceleration and deceleration time, up to 16 frequency segments can be set.

8: PID setting

Generally used in the field of closed-loop control, such as constant pressure closed-loop control, constant tension closed-loop control and other occasions. Closed loop control parameters can be set in group PA. VH5 has two groups of PID parameters to switch.

9: simple PLC operation

When the frequency source is simple PLC, the frequency converter operates according to the specified frequency, specified time and specified acceleration and deceleration time. The specific parameters can be set through group PB, and can run for up to 16 sections.

parameter	Name	Range
P0-04	Auxiliary frequency B input channel selection	0~9
P0-05	Frequency source superposition selection	Ones bit: frequency source selection 0: main frequency source A 1: Operation results of main and auxiliary frequency sources (determined by tens bits) 2: Switching between main frequency A and auxiliary frequency B
		Tens bit: Operation relationship of main and auxiliary frequency sources 0: A+B 1: A-B 2: max(A,B) 3: min(A,B)

The using method of auxiliary frequency channel is similar to the main frequency input channel P0-03.

Note: when the frequency source superposition is selected (P0-05 ones bit is 1), that is, when the VFD frequency is set by superposition of main and auxiliary frequency:

- (1) The auxiliary frequency input channel is digital setting (P0-04 = 0 or 1), and the preset frequency (P0-10) does not work any more. The frequency adjustment made by the user through keyboard keys (or up and down of X terminal) is directly based on the main frequency.
- (2) The auxiliary frequency input channel is analog or pulse setting (P0-04 = 2, 3, 4 or 5). 100% of the input setting corresponds to the range of auxiliary frequency source B, which is set through P0-06 and P0-07.
- (3) The main and auxiliary frequency sources cannot be set to the same channel, otherwise it is easy to

cause confusion.

Parameter	Name	Range
P0-06	Auxiliary frequency source B range selection	0: Relative to the maximum frequency 1: Relative to the main frequency source A
P0-07	Auxiliary frequency source B range	0%~150%

When the frequency source is selected as "frequency superposition" (P0-05 ones bit is 1), these two parameters are used to determine the adjustment range of the auxiliary frequency source.

P0-06 is used to determine the object corresponding to the range of the auxiliary frequency source. It can be selected as relative to the maximum frequency or relative to the main frequency source A. If it is selected as relative to the main frequency source, the range of the auxiliary frequency source will change with the change of the main frequency source A.

parameter	Name	Range
P0-09	Digital setting of auxiliary frequency source offset when superposition	0.00Hz~max output frequency (P0-13)

This parameter is only valid when the frequency source is selected as the main and auxiliary operation (P0-05 ones bit is 1).

When the frequency source is used as the main and auxiliary operation, P0-09 is used as the bias frequency, and the superposition of the main and auxiliary operation results is used as the final frequency setting value, which makes the frequency setting more flexible

parameter	Name	Range
P0-10	Preset frequency	0.00Hz~max output frequency (P0-13)

When the frequency input channel is set to digital setting, the parameter value is the initial value of frequency digital setting.

parameter	Name	Range	
P0-12	Digital setting frequency memory selection	0	No memory
		1	memory

Memory and no memory refers to the frequency adjustment by keyboard ▲ and key (or up and down of X terminal) during operation, and whether the changed frequency is memorized during shutdown. When no memory is selected, the frequency will return to the set value of P0-10 (preset frequency) after shutdown.

Note: when memory is selected, it is only applicable to normal shutdown. If power is cut off suddenly during operation, the frequency will not be memorized after power is turned on again.

parameter	Name	Range
P0-13	Max output frequency	50.00Hz~500.00Hz

Used to set the maximum output frequency of frequency converter.

Parameter	Name	Range	
P0-14	Upper limit frequency source	0	Set by P0-15
		2	AI
		5	Communication setting

The default upper limit frequency is set by P0-15. It can also be set by analog quantity (AI), and communication. When the operating frequency reaches the upper limit frequency, the upper limit frequency will be maintained.

Set the upper limit through analog quantity and pulse, please refer to P2-18~P2-45.

parameter	Name	Range
P0-15	Upper limit frequency	Lower limit frequency P0-17~ max output frequency P0-13

Set the upper limit frequency, the setting range is from lower limit frequency P0-17 to max output frequency P0-13

parameter	Name	Range
P0-16	Upper limit frequency offset	0.00Hz~max output frequency (P0-13)

When the upper limit frequency source P0-14 is set to analog or pulse setting, P0-16 is used as the offset of the set value, the offset frequency is added with the upper limit frequency value set by P0-14 to get the set value of the final upper limit frequency.

parameter	Name	Range
P0-17	Lower limit frequency	0.00Hz~upper limit frequency (P0-15)

Set the lower limit frequency. The range is from 0.00Hz to upper limit frequency (P0-15).

Parameter	Name	Range
P0-18	Acceleration time 1	0 ~ 65000 (PC-09=0) 0.0 ~ 6500.0 (PC-09=1) 0.00 ~ 650.00 (PC-09=2)
P0-19	Deceleration time 1	0 ~ 65000 (PC-09=0) 0.0 ~ 6500.0 (PC-09=1) 0.00 ~ 650.00 (PC-09=2)

Acceleration time refers to the time required for the frequency converter to accelerate from 0Hz to the acceleration/deceleration base frequency (PC-10). Similarly, deceleration time refers to the time required for the frequency converter to decelerate from the acceleration/deceleration base frequency to 0Hz; As shown in the figure, T1 and T3 are the actual acceleration and deceleration time, T2 and T4 are the set acceleration and deceleration time. The other three kinds of acceleration and deceleration time (PC-03 ~ PC-08) are the same.

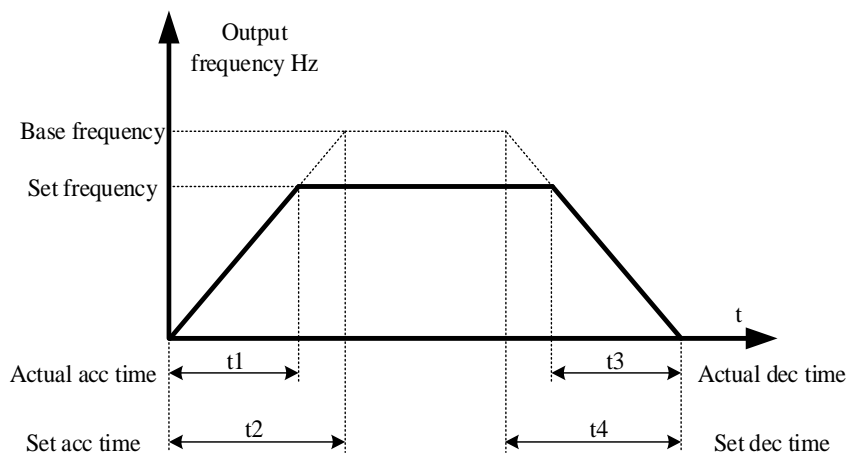

parameter	Name	Range	
P0-20	Operation direction	0	Default operation direction

		1	Runs in the opposite direction from the default
--	--	---	---

By changing the function code, the motor direction can be changed without changing the motor wiring, which is equivalent to changing the phase sequence of any two phases in the motor (U, V, W) to realize the conversion of motor rotation direction.

Note: after parameter initialization, the motor running direction will return to the original state. It is strictly forbidden to change the direction of the motor when the system is debugged.

Parameter	Name	Range	
P0-21	Reverse operation prohibition setting	0	Reverse run is allowed
		1	Reverse run is prohibited

When the motor is not allowed to run in the reverse direction, the parameter should be set to 1.

Parameter	Name	Range
P0-22	Dead time of forward and reverse rotation	0.0s~3000.0s

The transition time at the output 0Hz during the process of forward and reverse rotation is shown as t1 in the figure.

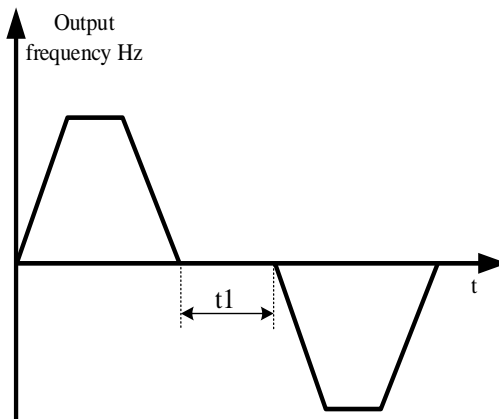

Parameter	Name	Range	
P0-23	frequency command UP/DOWN base when operation	0	Operation frequency
		1	Setting frequency

This parameter is only valid when the frequency source is digital setting.

This parameter is used to confirm the mode to modify the setting frequency when keyboard ▲, ▼ or terminal UP/DOWN acted, which means the target frequency is increased or decreased based on the operating frequency or the set frequency.

The difference between the two settings is obvious when the frequency converter is in the process of acceleration and deceleration, that is, if the operating frequency of the frequency converter is different from the set frequency, the different selection of this parameter is very different.

parameter	Name	Range	
P0-25	Motor parameter group selection	0	Motor parameter group 1
		1	Motor parameter group 2

VH5 series inverter can save two groups of motor parameters, and select the current working motor parameter group through P0-25. Two motors can set their own name plate parameters, and need to complete their own parameter tuning before operation. The parameters of motor parameter group 1 are P1 parameters, and the parameters of motor parameter group 2 are A2 parameters.

#### 4-2-2. Group P1 first motor parameters

parameter	Name	Range
P1-00	Motor type selection	0: Common asynchronous motor
P1-01	Motor rated power	0.1kW~650.0kW
P1-02	Motor rated voltage	1V~1200V
P1-03	Motor rated current	0.01A~655.35A (VFD power ≤55kW) 0.1A~6553.5A (VFD power >55kW)
P1-04	Motor rated frequency	0.01Hz~max output frequency
P1-05	Motor rated speed	1rpm~65535rpm

P1-00 ~ P1-05 are the parameters on the motor nameplate. It is recommended to input these parameters manually after getting the new product.

parameter	Name	Range
P1-06	Asynchronous motor stator resistance	0.001Ω~65.535Ω (VFD power≤55kW) 0.0001Ω~6.5535Ω (VFD power>55kW)
P1-07	Asynchronous motor rotor resistance	0.001Ω~65.535Ω (VFD power≤55kW) 0.0001Ω~6.5535Ω (VFD power>55kW)
P1-08	Leakage inductance of asynchronous motor	0.01mH~655.35mH (VFD power≤55kW) 0.001mH~65.535mH (VFD power>55kW)
P1-09	Mutual inductance of asynchronous motor	0.01mH~655.35mH (VFD power≤55kW) 0.001mH~65.535mH (VFD power>55kW)
P1-10	asynchronous motor no load current	0.01A~P1-03 (VFD power≤55kW) 0.1A~P1-03 (VFD power>55kW)

Generally, P1-06~P1-10 cannot be viewed on the motor body, and the response data will be automatically calculated and generated after the motor is tuned.

parameter	Name	Range
P1-35	Motor parameter self learning	0: no operation 1: Static tuning of asynchronous motor 2: Dynamic tuning of asynchronous motor

Generally speaking, the effect of dynamic tuning is better than that of static tuning. It is suggested to choose dynamic tuning, but dynamic tuning should separate the load from the motor. If it is difficult to separate the load from the motor, only static tuning can be selected. Both static tuning and dynamic tuning are only effective in vector mode, that is, when P0-01 is set to 1 or 2.

Tuning steps of vector control without speed sensor mode:

When P0-01 is set to 1, there is no sensor vector mode. Set P0-02 to 0 means panel control.

- (1) Set P1-00 ~ P1-05 according to the motor nameplate in turn.
- (2) If it is convenient to separate the load from the motor, dynamic tuning is used; if it is not convenient to separate, static tuning is used.

- (3) Take dynamic tuning as an example, set P1-35 to 2, then press the ENT key, the panel will display TUNE, then press the RUN key, the tuning will start, the TUNE light will flash slowly, and the tuning will be completed in about 2 minutes. After completion, the TUNE will disappear and the panel will display the frequency.

### 4-2-3. Group P2 input terminal multi-function parameters

VH5 series inverter is equipped with 4 multifunctional digital input terminals and 1 analog input terminal. Table 4-1 provides a detailed description of each function.

parameter	Name	Range
P2-00	Terminal X1 function selection	0~51
P2-01	Terminal X2 function selection	
P2-02	Terminal X3 function selection	
P2-03	Terminal X4 function selection	

Setting value	Function	Explanation
0	No function	The unused terminals can be set as "no function" to prevent misoperation.
1	FWD or run command	Control the inverter forward and reverse operation through the external terminal
2	REV or fwd/rev operation direction	
3	Three wire operation control	Set the inverter operation mode to three wire control mode through this terminal. Please refer to the description of function code P2-10 ("terminal command mode") for details.
4	Forward jog (FJOG)	FJOG is forward jog operation, RJOG is reverse jog operation. Please refer to the description of function code PC-01 and PC-02 for jog operation frequency and jog acceleration and deceleration time.
5	Reverse jog (RJOG)	
6	Terminal UP	When the frequency is given by the external terminal, the command to increase and decrease the frequency. When the frequency source is set to digital setting, the setting frequency can be adjusted up and down.
7	Terminal DOWN	
8	UP/DOWN setting reset (terminal, keyboard)	When the frequency is set through digital frequency, this terminal can clear the frequency value changed by terminal up/down or keyboard up/down, and make the given frequency return to the value set by P0-10.
9	Free stop	The inverter blocks the output, and the motor shutdown process is not controlled by the inverter. This mode has the same meaning as free stop in P4-22.
10	Fault reset (RESET)	Use the terminal to reset the fault. It has the same function as the reset key on the keyboard. With this function, remote fault reset can be realized.
11	Frequency source switching	Main and auxiliary frequency source switching
12	Multi-segment command terminal 1	Through the 16 states of the four terminals, the setting of 16 segment speed or 16 other commands can be realized. See the attached table

Setting value	Function	Explanation
13	Multi-segment command terminal 2	for details.
14	Multi-segment command terminal 3	
15	Multi-segment command terminal 4	
16	Acceleration/deceleration time selection terminal 1	Through the four states of the two terminals, four kinds of acceleration and deceleration time can be selected. See the attached table for details.
17	Acceleration/deceleration time selection terminal 2	
18	Acceleration and deceleration forbidden	Ensure that the frequency converter is not affected by external signals (except shutdown command), and maintain the current output frequency.
20	Length counting input	Length counting input terminal.
21	Length reset	Length reset.
22	Counter input	Counting pulse input terminal.
23	Counter reset	Reset the counter status
24	Swing frequency pause	The frequency converter outputs at the center frequency. The swing function is suspended.
25	Operation pause	The inverter decelerates and stops, but all operating parameters are memorized. Such as PLC parameters, swing frequency parameters, PID parameters. After the signal of this terminal disappears, the inverter will return to the running state before shutdown.
26	PLC status reset	PLC pauses in the process of execution. When it runs again, the inverter can be restored to the initial state of simple PLC through this terminal.
27	Operation command switches to keyboard	When the terminal is valid, the operation command is switched to the keyboard
28	Operation command switches to communication	When the terminal is valid, the operation command is switched to communication
29	Torque control inhibition	It is forbidden for the inverter to control the torque, and the inverter enters the speed control mode.
30	Speed control/torque control switching	The converter is switched between torque control and speed control. When the terminal is invalid, the inverter operates in the mode defined by (PF-00). If the terminal is valid, it will be switched to another mode. During operation, it can be switched through the terminal, and the switch will take effect immediately
32	PID pause	PID is temporarily invalid, the inverter maintains the current output frequency, and no longer adjusts the PID of frequency source.
33	Reverse action direction of PID	When the terminal is effective, the PID function reverses
34	PID integral pause	When the terminal is valid, the integral regulation function of PID is suspended, but the proportional regulation and differential regulation function of PID are still valid.

Setting value	Function	Explanation
35	PID parameter switching	When the PID parameter switching condition is terminal X (PA-13), and the terminal is invalid, the PID parameters use PA-10 ~ PA-12; When the terminal is valid, PA-16 ~ PA-18 are used.
36	External fault normally ON input	When the signal is sent to the frequency converter, the frequency converter will report the fault Err43 and deal with the fault according to the action mode of fault protection (see function code P7-46 for details).
37	External fault normally close input	When the normally closed signal of external fault is sent to the inverter, the inverter reports the fault err43 and stops.
38	User defined fault 1	When user defined fault 1 and 2 are valid, the frequency converter alarms Err48 and Err49 respectively. The frequency converter will handle according to the action mode selected by fault protection action selection (P7-47).
39	User defined fault 2	
40	Motor parameter selection terminal	Two groups of motor parameters can be switched through the two states of terminals.
41	Switching between main frequency source A and preset frequency	If the terminal is valid, frequency source A is replaced by preset frequency (P0-10)
42	Switching between main frequency source B and preset frequency	If the terminal is valid, frequency source B is replaced by preset frequency (P0-10)
43	Frequency setting active terminal	When the terminal is valid, it is allowed to modify the frequency; If it is invalid, it is forbidden to modify the frequency
44	DC brake	When the terminal is valid, the inverter will switch to DC braking state directly
45	Deceleration DC braking	When the terminal is effective, the frequency converter first decelerates to the starting frequency of DC braking, and then switches to the DC braking state.
46	Emergency stop	When the terminal is effective, the inverter stops at the fastest speed, and the current is in the upper limit of the set current during the stop process. This function is used to meet the needs of the inverter to stop as soon as possible when the system is in emergency.
47	External stop terminal 1	When keyboard control, the terminal can be used to stop the inverter, which is equivalent to the function of stop key on the keyboard
48	External stop terminal 2	In any control mode (panel control, terminal control, communication control), the terminal can be used to slow down the frequency converter, and the deceleration time is fixed as deceleration time 4.
49	Reverse inhibit	The terminal is effective, and inverter reversal is prohibited.
50	The running time is cleared	When the terminal is valid, the inverter operation time is cleared. This function needs to be matched and used with the timing operation (PC-28) and the current operation time (PC-29).
51	Two wire / three wire switching	Used to switch between two-wire and three-wire mode



Four multi-segment command terminals can be combined into 16 states, each of which corresponds to 16 command settings. The details are as follows:

K4	K3	K2	K1	Command setting	Parameter
OFF	OFF	OFF	OFF	Multi-segment command 0	PB-00 (PB-16=0)
OFF	OFF	OFF	ON	Multi-segment command 1	PB-01
OFF	OFF	ON	OFF	Multi-segment command 2	PB-02
OFF	OFF	ON	ON	Multi-segment command 3	PB-03
OFF	ON	OFF	OFF	Multi-segment command 4	PB-04
OFF	ON	OFF	ON	Multi-segment command 5	PB-05
OFF	ON	ON	OFF	Multi-segment command 6	PB-06
OFF	ON	ON	ON	Multi-segment command 7	PB-07
ON	OFF	OFF	OFF	Multi-segment command 8	PB-08
ON	OFF	OFF	ON	Multi-segment command 9	PB-09
ON	OFF	ON	OFF	Multi-segment command 10	PB-10
ON	OFF	ON	ON	Multi-segment command 11	PB-11
ON	ON	OFF	OFF	Multi-segment command 12	PB-12
ON	ON	OFF	ON	Multi-segment command 13	PB-13
ON	ON	ON	OFF	Multi-segment command 14	PB-14
ON	ON	ON	ON	Multi-segment command 15	PB-15

When the frequency source is multi-speed, 100.0% of the function code PB-00 ~ PB-15 corresponds to the maximum frequency P0-13. In addition to the function of multi-stage speed, the multi-stage instruction can also be used as the given source of PID, or as the voltage source of VF separation control, so as to meet the needs of switching between different given values.

Terminal 2	Terminal 1	Acc/dec time	Parameter
OFF	OFF	Acceleration time 1	P0-18, P0-19
OFF	ON	Acceleration time 2	PC-03, PC-04
ON	OFF	Acceleration time 3	PC-05, PC-06

ON	ON	Acceleration time 4	PC-07, PC-08
----	----	---------------------	--------------

Parameter	Name	Function
P2-10	terminal command mode	0: two-wire mode 1 1: two-wire mode 2 2: three-wire mode 1 3: three-wire mode 2

This parameter defines four different ways to control the operation of the inverter through the external terminal. Note: for the convenience of explanation, the following three terminals X1, X2 and X3 of the multifunctional input terminals X1 ~ X4 are randomly selected as the external terminals. That is to say, the functions of X1, X2 and X3 are selected by setting the values of P2-00 ~ P2-02. See the setting range of P2-00 ~ P2-05 for detailed function definition.

0: two-wire mode 1. This mode is the most commonly used two-wire mode. The forward and reverse operation of the motor is determined by terminals X1 and X2. The function code setting is as follows:

Parameter	Name	Range	Function
P2-10	Terminal command mode	0	Two-wire mode 1
P2-00	X1 function selection	1	Forward run
P2-01	X2 function selection	2	Reverse run

K1	K2	Command
1	0	Forward
0	1	Reverse
1	1	Stop
0	0	Stop

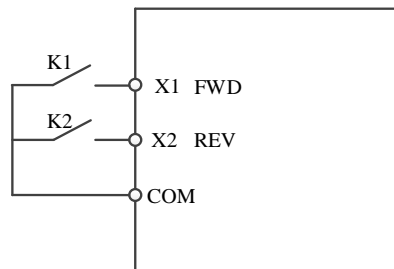

As shown in the figure, in this control mode, K1 is closed and the frequency converter is running forward. K2 is closed and VFD is running reversed, K1 and K2 are closed or disconnected at the same time, and the inverter stops running.

1: Two-wire mode 2, in this mode, X1 terminal function is operation enable terminal, while X2 terminal function determines operation direction. The function code setting is as follows:

Parameter	Name	Range	Function
P2-10	Terminal command mode	1	Two-wire mode 1
P2-00	X1 function selection	1	Forward run
P2-01	X2 function selection	2	Reverse run

K1	K2	Command
1	0	Forward
1	1	Reverse
0	0	Stop
0	1	Stop

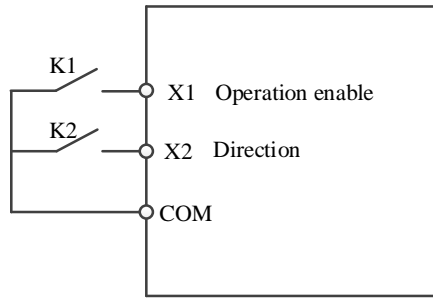

As shown in the figure, in the control mode of K1 closed state, K2 opens and the inverter rotates forward, K2 closes and the inverter reverses; K1 is disconnected and the inverter stops.

2: three-wire mode 1, in this mode X3 is enable terminal, X1 and X2 control the direction.

The function code setting is as follows:

Parameter	Name	Range	Function
P2-10	Terminal command mode	2	Three-wire mode 1
P2-00	X1 function selection	1	Forward run
P2-01	X2 function selection	2	Reverse run
P2-02	X3 function selection	3	Three-wire control mode

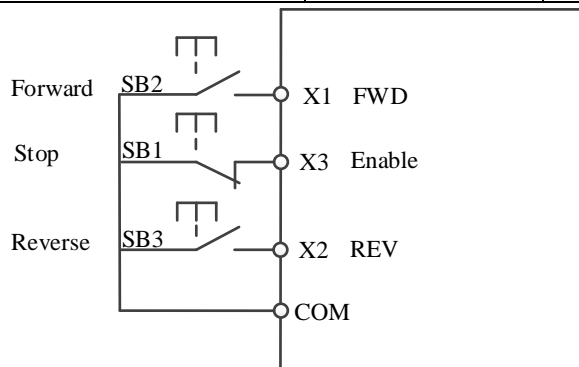

As shown in the figure, in the control mode, when SB1 button is closed, press SB2 button, the frequency converter rotates forward, and then press SB3 button, the frequency converter reverses, SB1 button is disconnected, and the frequency converter stops. During normal start-up and operation, SB1 button must be kept closed, SB2 and SB3 button commands will take effect at the closing action edge, and the operation state of frequency converter is subject to the last action of the three buttons.

3: three-wire control mode 2, in this mode, X2 is enable terminal, X1 controls the operation, X3 controls the direction.

The function code setting is as follows:

Parameter	Name	Range	Function
P2-10	Terminal command mode	3	Three-wire mode 2
P2-00	X1 function selection	1	Enable
P2-01	X2 function selection	3	Direction
P2-02	X3 function selection	2	Three-wire control mode

K	Command
0	Forward
1	Reverse

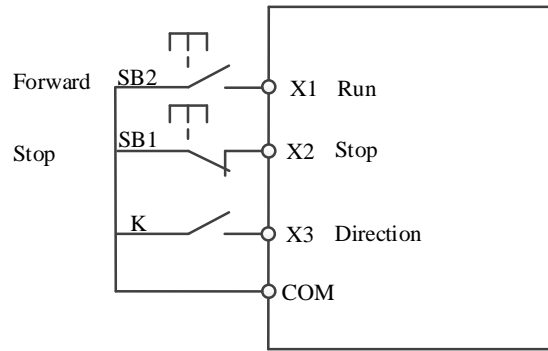

As shown in the figure, in the SB1 button closed state, press the SB2 button, the frequency converter runs, K opens the frequency converter forward, K closes the frequency converter reverse; When SB1 button is off, the inverter stops. During normal start-up and operation, SB1 button must be kept closed, and SB2 button command will take effect at the closing action edge.

Parameter	Name	Range
P2-11	Terminal UP/DOWN changing rate	0.001Hz/s~50Hz/s

It is used to set the speed of frequency change when the terminal up / down adjusts the set frequency, that is, the change of frequency per second.

Parameter	Name	Range
P2-12	X filter time	0.000s~1.000s

Set the software filter time of X terminal state. If the input terminal is easy to be disturbed and cause misoperation, this parameter can be increased to enhance the anti-interference ability. However, the increase of the filtering time will slow down the response of the X terminal.

Parameter	Name	Range
P2-13	X1 delay time	0.0s~3600.0s
P2-14	X2 delay time	0.0s~3600.0s
P2-15	X3 delay time	0.0s~3600.0s

It is used to set the delay time of frequency converter when the state of X terminal changes. At present, only X1, X2 and X3 have the function of setting the delay time.

Parameter	Name	Content	Range
P2-16	X1 terminal valid state setting	Ones bit	0: high level valid; 1: low level valid
	X2 terminal valid state setting	Tens bit	0: high level valid; 1: low level valid
	X3 terminal valid state setting	Hundreds bit	0: high level valid; 1: low level valid
	X4 terminal valid state setting	Thousands bit	0: high level valid; 1: low level valid

This function code is used to set the effective state of the input terminal of the inverter.

Parameter	Name	Range
P2-22	AI curve 2 min setting	0.00V~P2-24
P2-23	AI curve 2 min setting corresponding frequency percentage	-100.0%~+100.0%
P2-24	AI curve 2 max setting	P2-22~+10.00V
P2-25	AI curve 2 max setting corresponding frequency percentage	-100.0%~+100.0%

AI curve parameters are used to set the relationship between analog input voltage and its representative setting value, as shown in the figure below.

When the analog input is greater than the maximum setting (less than the minimum setting), it is calculated according to the maximum setting (minimum setting). Two typical settings are provided as follows:

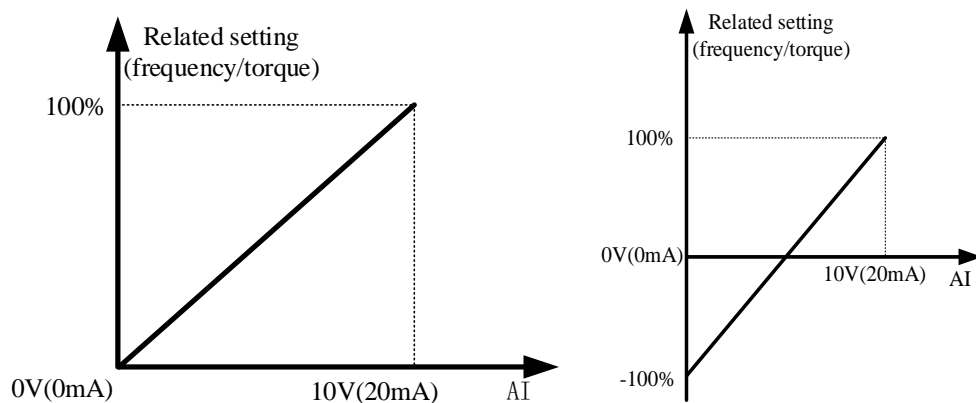

The functions of AI curve 1 (P2-18~P2-21) /AI curve 3 (P2-26~P2-29) are same to AI curve2.

By default, the corresponding relationship between AI input voltage value and target frequency is curve 2, and the corresponding parameters are set at P2-22-P2-25.

Parameter	Name	Range
P2-30	AI curve 4 min input	0V~P2-32
P2-31	AI curve 4 minimum input corresponding setting	-100.0%~+100.0%
P2-32	AI curve 4 inflection point 1 input	P2-30~P2-34
P2-33	AI curve 4 inflection point 1 input corresponding setting	-100.0%~+100.0%
P2-34	AI curve 4 inflection point 2 input	P2-32 ~ P2-36
P2-35	AI curve 4 inflection point 2 input corresponding setting	-100.0% ~ +100.0%
P2-36	AI curve 4 max input	P2-34 ~ +10.00V
P2-37	AI curve 4 max input corresponding setting	-100.0% ~ +100.0%
P2-38	AI curve 5 min input	-10.00V ~ P2-40
P2-39	AI curve 5 minimum input corresponding setting	-100.0% ~ +100.0%
P2-40	AI curve 5 inflection point 1 input	P2-38 ~ P2-42
P2-41	AI curve 5 inflection point 1 input corresponding setting	-100.0% ~ +100.0%

Parameter	Name	Range
P2-42	AI curve 5 inflection point 2 input	P2-40 ~ P2-44
P2-43	AI curve 5 inflection point 2 input corresponding setting	-100.0% ~ +100.0%
P2-44	AI curve 5 max input	P2-42 ~ +10.00V
P2-45	AI curve 5 max input corresponding setting	-100.0% ~ +100.0%

Curve 4 is determined by four points, which is more flexible, refer to the following figure.

The voltage/current should meet the requirement: AI min input (P2-30) < AI curve inflection point 1 input (P2-32) < AI curve inflection point 2 input (P2-34) < AI max input (P2-36).

Curve 5 please refer to the explanation of curve 4.

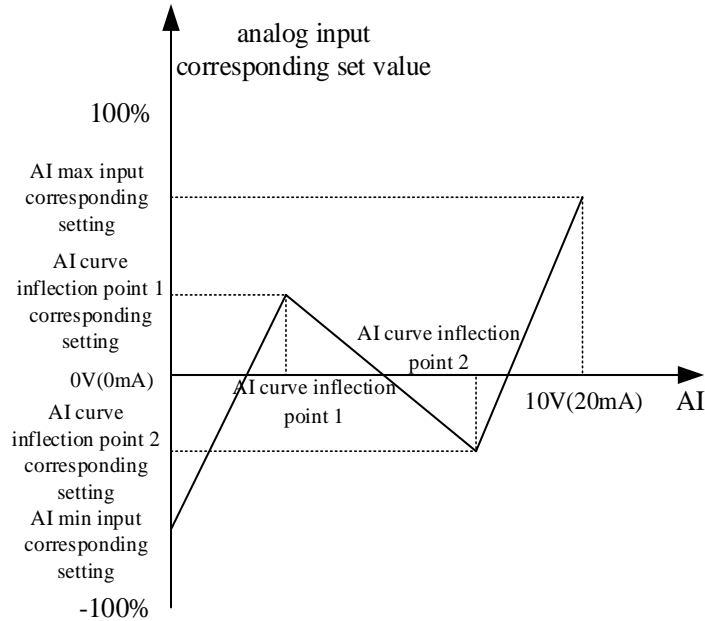

Parameter	Name	Range	
P2-54	AI curve selection	Tens bit	AI curve selection
		1	Curve 1 (2 points, refer to P2-18~P2-21)
		2	Curve 2 (2 points, refer to P2-22~P2-25)
		3	Curve 3 (2 points, refer to P2-26~P2-29)
		4	Curve 4 (4 points, refer to P2-30~P2-37)
		5	Curve 5 (4 points, refer to P2-38~P2-45)

Curve 1, curve 2 and curve 3 are linear relations determined by two coordinate points; Curve 4 and curve 5 are broken line relations determined by four coordinate points.

Parameter	Name	Range	
P2-55	AI below minimum input setting selection	Ones bit	AI below minimum input setting selection
		0	Corresponding minimum input setting
		1	0.0%

If 0 is selected, when AI input is lower than "minimum input", the corresponding setting of the analog quantity is the "minimum input corresponding setting" (P2-18, P2-22, P2-26) of the curve determined by the parameters. If 1 is selected, when AI input is lower than the minimum input, the corresponding setting of the analog quantity is 0.0%.

Parameter	Name	Range
P2-57	AI filter time constant	0.00s~10.00s

AI filtering time constant is used to set the software filtering time of AI. When the on-site analog quantity is easy to be interfered, please increase the filtering time to make the detected analog quantity tend to be stable, but the larger the filtering time, the slower the response speed of analog quantity detection.

Parameter	Name	Range
P2-62	AI jump point	-100%~+100.0%
P2-63	AI jump range	0.0%~100.0%

The jump function is to fix the corresponding setting value of the analog quantity to the jump point when the corresponding setting of the analog quantity changes in the upper and lower intervals of the jump point.

For example: the voltage of analog input AI fluctuates up and down at 5.00V, the fluctuation range is 4.90V ~ 5.10V, the minimum input of AI 0.00V corresponds to 0.0%, and the maximum input of AI 10.00V corresponds to 100%. Then the detected AI corresponding setting fluctuates between 49.0% and 51.0%.

Set AI jump point P2-60 to 50.0%, set AI jump range P2-61 to 1.0%, then the AI1 input is fixed to 50.0%, after jump function processing, AI is transformed into a stable input, and the fluctuation is eliminated.

#### 4-2-4. Group P3 output terminal multi-function parameters

Each output channel function can be defined through setting parameter P3-01, P3-04.

Parameter	Name	Range
P3-01	Y1 output function selection	0~42 code functions are as follows
P3-04	Relay 1 output function selection	

Setting value	Function	Explanation
0	No output	The output terminal has no function
1	Inverter in operation	Indicates that the inverter is in operation state, with output frequency (can be zero), output ON signal.
2	Fault output (free stop fault)	When the inverter fails and stops, the ON signal is output.
3	Frequency level detection FTD1 output	Refer to PC-18, PC-19 explanation.
4	Frequency level detection FTD2 output	Refer to PC-20, PC-21 explanation.
5	Frequency reached	Refer to PC-22 explanation.
6	Zero speed operation (no output during shutdown)	When the frequency converter runs and the output frequency is 0, the ON signal is output. When the frequency converter is in the shutdown state, the signal is off.
7	Zero speed operation 2 (output during shutdown)	When the inverter output frequency is 0, the ON signal is output. The signal is also on in the shutdown state.
8	Upper limit frequency arrival	When the operating frequency reaches the upper frequency, the ON signal is output.
9	Lower limit frequency arrival (no	When the operating frequency reaches the lower frequency,

Setting value	Function	Explanation
	output when shutdown)	the ON signal is output. The signal is off in the shutdown state.
10	Motor overload warning	Before the motor overload protection action, it is judged according to the threshold of overload warning, and the ON signal is output after exceeding the threshold. Refer to function code P7-33-P7-41 for setting motor overload parameters.
11	Frequency converter overload warning	The ON signal is output 10s before the overload protection of frequency converter.
12	Communication setting	Refer to communication protocol.
13	Torque limit	When the set frequency exceeds the upper or lower frequency, and the frequency of the frequency converter also reaches the upper or lower frequency, the ON signal is output.
15	Frequency 1 arrival output	Refer to PC-22, PC-23.
16	Frequency 2 arrival output	Refer to PC-24, PC-25.
17	Current 1 arrival output	Refer to PC-34, PC-35.
18	Current 2 arrival output	Refer to PC-36, PC-37.
19	The set value is reached	When the count value reaches the value set by A0-03, the ON signal is output.
20	The specified value arrived	When the count value reaches the value set by A0-04, the ON signal is output. The counting function is shown in the function description of group A0.
21	Ready to run	When the power supply of the main circuit and control circuit of the frequency converter is stable, and the frequency converter does not detect any fault information, and the frequency converter is in the operational state, the ON signal is output.
23	AI1 input overrun	When the value of analog input AI1 is greater than PC-43 (upper limit of AI1 input protection) or less than PC-42 (lower limit of AI1 input protection), the ON signal is output.
24	Under voltage state output	When the inverter is under voltage, it outputs ON signal.
25	Power on time arrived	When the accumulated power on time (U0-30) of the inverter exceeds the time set by PC-30, the ON signal is output.
26	Timing arrival	When the timing function (PC-26) is valid, the inverter will output ON signal when the running time reaches the set timing time (PC-28).
27	Length arrival	When the actual length detected exceeds the length set by A0-00, the ON signal is output.
28	Simple PLC cycle completion	When the simple PLC completes a cycle, it outputs a pulse signal with a width of 250ms.
29	Run time arrival	When the accumulated operation time P8-10 of the inverter



Setting value	Function	Explanation
		exceeds the time set by PC-32, the ON signal is output.
30	Reserved	Reserved
31	Reserved	Reserved
32	Lower frequency arrival (operation related)	When the operating frequency reaches the lower frequency, the ON signal is output. The signal is off in the shutdown state.
33	Fault output (free shutdown fault and no output when under voltage)	Fault of free shutdown and no output when under voltage.
34	Module temperature arrival	When the inverter module radiator temperature (P8-19) reaches the set module temperature (PC-47), the ON signal is output
35	Fault output (output only after fault shutdown)	When the frequency converter fails, and the fault processing mode is continue to run, the frequency converter alarm output.
36	Motor over temperature alarm	Motor temperature acquisition value is greater than P7-37 value, alarm output
37	Speed direction	When the inverter is in reverse operation, it outputs ON signal.
38	Load dropping	Load suddenly unloaded
39	Software overcurrent output	Refer to PC-40, PC-41.
40	Current detection arrival output	Refer to PC-38, PC-39.
41	Current run time arrival	When the starting time of the frequency converter exceeds the time set by PC-29, the ON signal will be output.
42	Bus voltage reached	Refer to PC-65, PC-66

Parameter	Name	Range
P3-06	Y1 output delay time	0.0~3600.0s
P3-07	Y2 (normal terminal) output delay time	0.0~3600.0s
P3-09	Relay 1 output delay time	0.0~3600.0s
P3-10	Relay 2 output delay time	0.0~3600.0s

It is used to set the delay time when the state of Y terminal changes.

Parameter	Name	Range
P3-11	Y terminal effective state selection	Ones bit: Y1 Tens bit: Y2 Hundreds bit: reserved Thousands bit: relay 1 Ten thousand bit: relay 2 0: Positive logic close valid / open invalid 1: negative logic close invalid/open valid

Parameter	Name	Range
P3-13	AO output function selection	0 ~ 13 see the following table for detailed parameter function description

Setting value	Function	Explanation
0	Operation frequency	0~max output frequency
1	Set frequency	0~ max output frequency
2	Output current	0-2 times motor rated current
3	Motor output torque (absolute, Percentage relative to motor)	0 ~ 2 times motor rated torque
4	Output power	0~2 times rated power
5	Output voltage	0~1.2 times VFD rated voltage
7	AI	0V~10V (or 0~20mA)
10	Output speed	0~ Output speed corresponding to maximum frequency
11	Communication control output	0.0%~100.0%
12	Counting value	0~max counting value
13	Length	0~max setting length

Parameter	Name	Range
P3-15	AO zero bias coefficient	-100.0~+100.0%
P3-16	AO gain	-10.00~+10.00

The above function codes are generally used to correct the zero drift of analog output and the deviation of output amplitude. It can also be used to customize the required AO output curve.

If the bias is represented by b, the gain is represented by k, the actual output is represented by Y, and the standard output is represented by X, then the actual output is:

$$Y = kX + b$$

Among them, 100% of the bias coefficient of AO1 corresponds to 10V (or 20mA), and the standard output refers to the amount of 0V ~ 10V (or 0mA ~ 20mA) corresponding to the analog output without bias and gain correction.

For example, if the analog output content is the operating frequency, and you want the actual output to be 8V (or 16mA) when the frequency is 0, as shown in the figure below, you need to set the zero offset to "80%"; If you want to output 3V (or 6mA) at the maximum frequency, as shown in the figure below, you need to set the gain to "- 0.50".

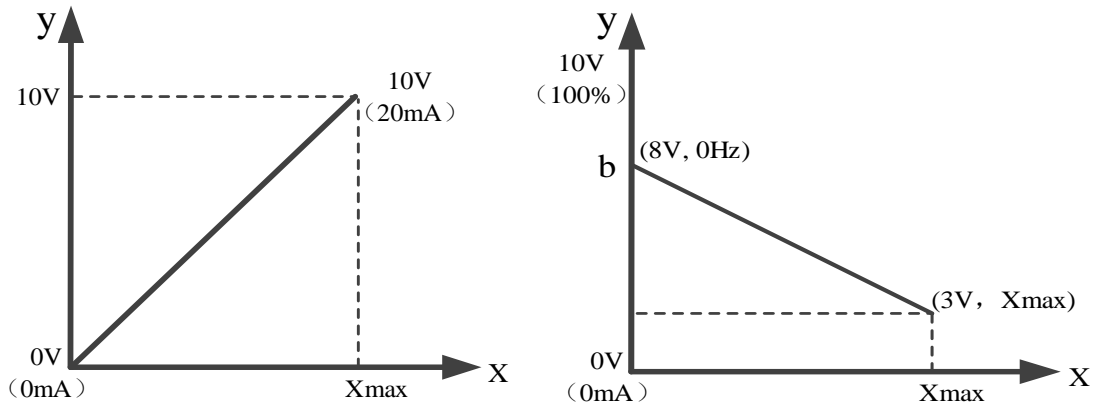

$$\text{Zero bias coefficient} = \frac{\text{output at 0Hz}}{\text{max output}} \times 100\%$$

$$\text{Gain} = \frac{\text{output at max frequency} - \text{output at 0Hz}}{\text{max output}}$$

#### 4-2-5. Group P4 startup brake parameters

Parameter	Name	Range
P4-00	Startup mode	0: direct start 1: Speed tracking restart 2: Pre-excitation start (AC asynchronous motor)

0: direct start

Suitable for small inertia load

1: Speed tracking restart

It is suitable for the case of instantaneous power loss and restart of large inertia load. At this time, the corresponding parameters of PA group should be set correctly;

2: Pre-excitation start (AC asynchronous motor)

It is only effective for AC asynchronous motor, and magnetic field is established before motor is running. If the pre-excitation time P4-04 is not 0, the dynamic response performance of the motor can be improved by pre-excitation and then starting. If the pre-excitation time is set to 0, the frequency converter cancels the pre-excitation process and starts from the start frequency.

Parameter	Name	Range
P4-01	Starting frequency	0.00Hz~10.00Hz
P4-02	Start frequency duration	0.0s~100.0s
P4-03	Starting DC brake current/pre-excitation current percentage	0%~100%
P4-04	DC braking time during startup/pre-excitation time	0.0s~100.0s

If the starting DC braking time is set to 0, the frequency converter starts to run from the starting frequency.

If the starting DC braking time is not 0, the DC braking is performed first, and then run at the starting frequency.

It is suitable for small inertia load, where the motor may rotate when starting.

Starting DC braking is only effective when the starting mode is direct starting. At this time, the inverter starts

DC braking according to the set starting DC braking current, and then starts to run after starting DC braking time. If the DC braking time is set to 0, it will start directly without DC braking. The greater the DC braking current is, the greater the braking force is.

If the starting mode is pre-excitation starting of asynchronous motor, the frequency converter first establishes the magnetic field according to the set pre-excitation current P4-03, and then starts to run after the set pre-excitation time P4-04. If the pre-excitation time is set to 0, it will start directly without pre-excitation process.

When the rated current of the motor is less than or equal to 80% of the rated current of the inverter, it is the percentage base value relative to the rated current of the motor; When the motor rated current is greater than 80% of the rated current of the inverter, it is relative to 80% of the rated current of the inverter as the percentage base value.

Parameter	Name	Range
P4-05	Starting protection selection	0: no protection 1: with protection

If P4-05 is set to 1, when the frequency converter start-up and stop is set to terminal start-up and stop, the start-up terminal will be triggered again after power failure and restart.

Parameter	Name	Range
P4-06	Speed tracking mode	0: starting from the shutdown frequency 1: starting from power frequency 2: Starting from maximum output frequency
P4-07	Speed tracking speed	1~100

In order to realize the smooth and shock free starting of the rotating motor. The inverter first judges the speed and direction of the motor, and then starts the motor with the tracking frequency. There are three ways to track the speed:

0: Track down from the frequency of power failure, which is usually selected.

1: It can be used when the power frequency is switched, and it can be used when the power is cut off for a long time.

2: Track down from the maximum frequency, often used by power generating load.

P4-07 is used to set the tracking speed when the speed tracking is restarted. The larger the parameter setting value is, the faster the tracking speed is. However, too much leads to unreliable tracking effect.

Parameter	Name	Range
P4-10	Speed tracking closed loop current	30%~200%

The maximum current in the speed tracking process is limited within the set value of "speed tracking current". If the setting value is too small, the effect of speed tracking will be worse.

Parameter	Name	Range
P4-19	Acceleration deceleration mode	0: linear acceleration and deceleration 1: Continuous S-curve acceleration and deceleration 2: Intermittent S-curve acceleration and deceleration

0: linear acceleration and deceleration

The output frequency increases or decreases linearly. Four kinds of acceleration and deceleration time (P0-18 ~ P0-19, PC-03 ~ PC-08) can be selected through the multi-function input terminal (P2-00 ~ P2-09).

1: Continuous S-curve acceleration and deceleration

When the target frequency is fixed, the output frequency is increased or decreased according to the S curve. It is suitable for the case of slow start or shutdown.

## 2: Intermittent S-curve acceleration and deceleration

It is suitable for the real-time change of target frequency and rapid response. The output frequency is increased or decreased in real time according to S curve. It is suitable for occasions with high comfort requirements and fast response.

Parameter	Name	Range
P4-20	S curve starting segment proportion	0.0%~(100.0%-P4-21)
P4-21	S curve end segment proportion	0.0%~(100.0%-P4-20)

When selecting static S-curve, the sum of parameters P4-20 and P4-21 must be less than or equal to 100%.

In the figure,  $t_1$  is the proportion of the beginning segment of S-curve defined by p4-20,  $t_2$  is the proportion of the end segment of S-curve defined by P4-21, and the slope of output frequency change between  $t_1$  and  $t_2$  is a fixed value, which is linear acceleration and deceleration. As shown in the figure.

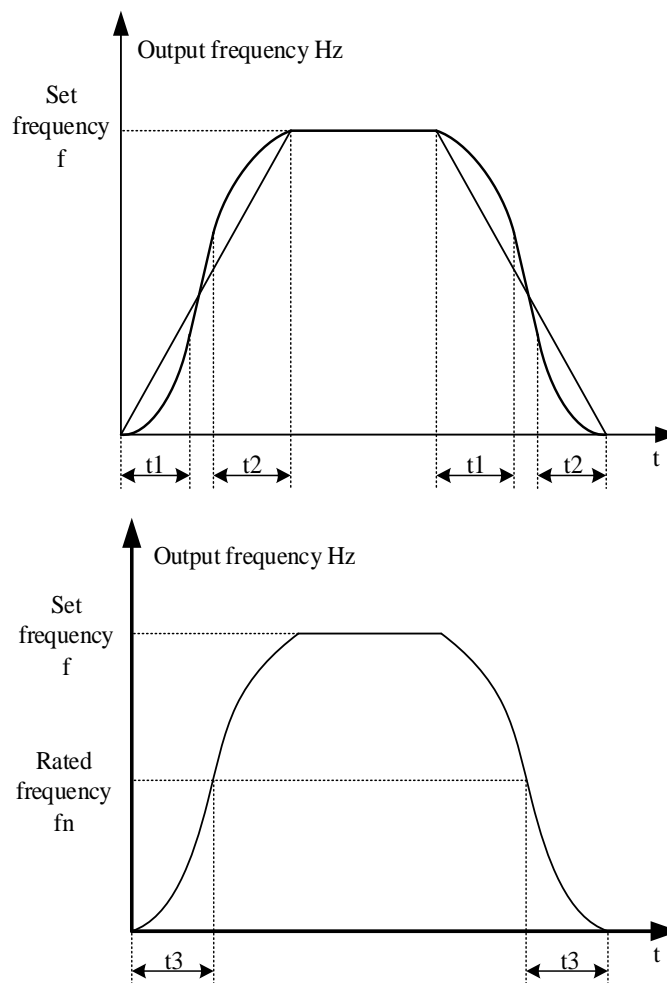

Parameter	Name	Range
P4-22	Stop mode	0: deceleration stop 1: free stop
P4-23	Starting frequency of DC braking during shutdown	0.00Hz~max output frequency P0-06
P4-24	DC braking time during shutdown	0.0s~100.0s
P4-25	Percentage of DC braking current at	0%~100%

	shutdown	
P4-26	DC brake waiting time during shutdown	0.0s~100.0s

The purpose of DC braking during shutdown is to stop quickly. For some objects with large inertia, the frequency of frequency converter may decrease, but the load inertia is large and the speed does not decrease. The object can be stopped quickly by DC braking. Braking process: the frequency converter drops according to the set deceleration time. When the frequency drops to P4-23, wait for the time set by P4-26, and then brake with the current set in P4-25. The braking time is P4-24.

Parameter	Name	Range
P4-27	Brake utilization rate	0%~100%

It is used to adjust the duty cycle of the moving unit. If the braking utilization rate is high, the duty cycle of the braking unit is high and the braking effect is strong, but the bus voltage of the inverter fluctuates greatly during the braking process.

#### 4-2-6. Group P5 VF parameters

Parameter	Name	Range	
		0	Line VF
P5-00	VF curve setting	1	Multi-point VF
		2	Square VF
		3	The 1.2nd power VF
		4	The 1.4th power VF
		6	The 1.6th power VF
		8	The 1.8th power VF
		9	Reserved
		10	VF complete separation mode
		11	VF half separation mode

0: line VF

Suitable for common constant torque load.

1: multi-point VF

Suitable for dehydrator, centrifuge and other special loads. By setting P5-01 ~ P5-06 parameters, any VF relation curve can be obtained.

2: Square VF

Suitable for centrifugal loads such as fans and pumps.

3: the 1.2<sup>nd</sup> power VF||4: the 1.4<sup>th</sup> power VF||6: the 1.6<sup>th</sup> power VF||8: the 1.8<sup>th</sup> power VF

VF relationship curve between line VF and square VF.

10: VF complete separation mode

The output frequency and voltage of the inverter are independent of each other. The output frequency is determined by the frequency source and the output voltage is determined by P5-09 (VF separated voltage source).

11: VF half separation mode

In the VF half separation mode, V and F are proportional, but the proportional relationship can be set through the voltage source P5-09, and the relationship between V and F is also related to the rated voltage and rated frequency of the motor in group F1.

The relationship between VFD output voltage V and frequency F:

$$\frac{V}{F} = \frac{2 \times A \times \text{motor rated voltage}}{\text{motor rated power}}$$

, A is percentage of voltage source input (0~100%).

Parameter	Name	Range
P5-01	Multi-point VF frequency point F1	0.00Hz~P5-03
P5-02	Multi-point VF voltage point V1	0.0~100.0%
P5-03	Multi-point VF frequency point F2	P5-01~P5-05
P5-04	Multi-point VF voltage point V2	0.0~100.0%
P5-05	Multi-point VF frequency point F3	P5-05~ (motor rated frequency) P1-04
P5-06	Multi-point VF voltage point V3	0.0~100.0%

When P5-00 = 1, the VF curve user-defined multi-point VF curve, as shown in the figure below, the user uses (V1, F1), (V2, F2), (V3, F3) three-point broken line mode to define the VF curve to adapt to the special load requirements.

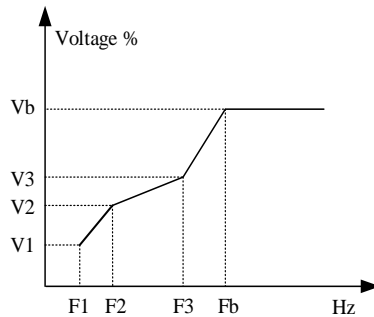

Note: V1 ~ V3: voltage percentage of section 1 ~ 3 of multipoint VF curve. F1 ~ F3: frequency point of section 1 ~ 3 of multipoint VF curve.

Parameter	Name	Range
P5-07	Torque boost	0.0% (auto torque boost) 0.1%~30.0%
P5-08	Torque boost cutoff frequency	0.00Hz~max output frequency P0-13

Torque boost can improve the low frequency torque characteristics of VF, reduce the torque boost when the load is light, and increase when the load is heavy and the starting torque is not enough. When the torque boost is too large, the motor will be over excited, the output current of the inverter will increase, the motor heating will increase, and the efficiency will decrease.

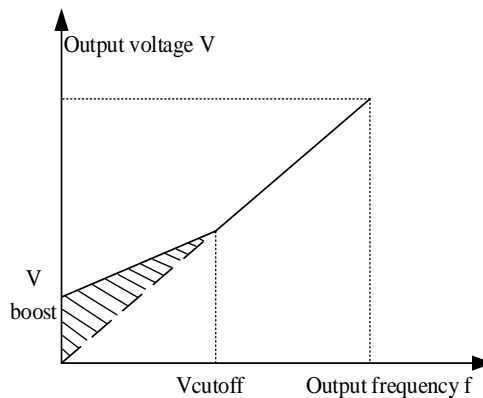

Parameter	Name	Range	
P5-09	The voltage source of VF separation	0	Digital setting (P5-10)

		2	AI
		5	Multi-segment command
		6	Simple PLC
		7	PID
		8	Communication setting
		100.0% corresponding to motor rated voltage (P1-02, A2-02)	
P5-10	Voltage source digital setting of VF separation	0V~motor rated voltage	

VF separation is generally used in induction heating, inverter power supply and torque motor control.

When VF separation control is selected, the output voltage can be set by parameter P5-10, or from analog quantity, multi-section instruction, PLC, PID or communication. When non digital setting is used, 100% of each setting corresponds to the rated voltage of the motor. When the percentage of analog output setting is negative, the absolute value is taken as the effective setting value.

Parameter	Name	Range
P5-11	Voltage acceleration time of VF separation	0.0s~1000.0s Note: it indicates the time when 0V changes to the motor rated voltage
P5-12	Voltage deceleration time of VF separation	0.0s~1000.0s Note: it indicates the time when 0V changes to the motor rated voltage

The voltage rise time of VF separation refers to the time required for the output voltage to accelerate from 0 to the motor rated voltage, as shown in t1 in the figure below.

The voltage drop time of VF separation refers to the time required for the output voltage to decelerate from the motor rated voltage to 0, as shown in t2 in the figure below.

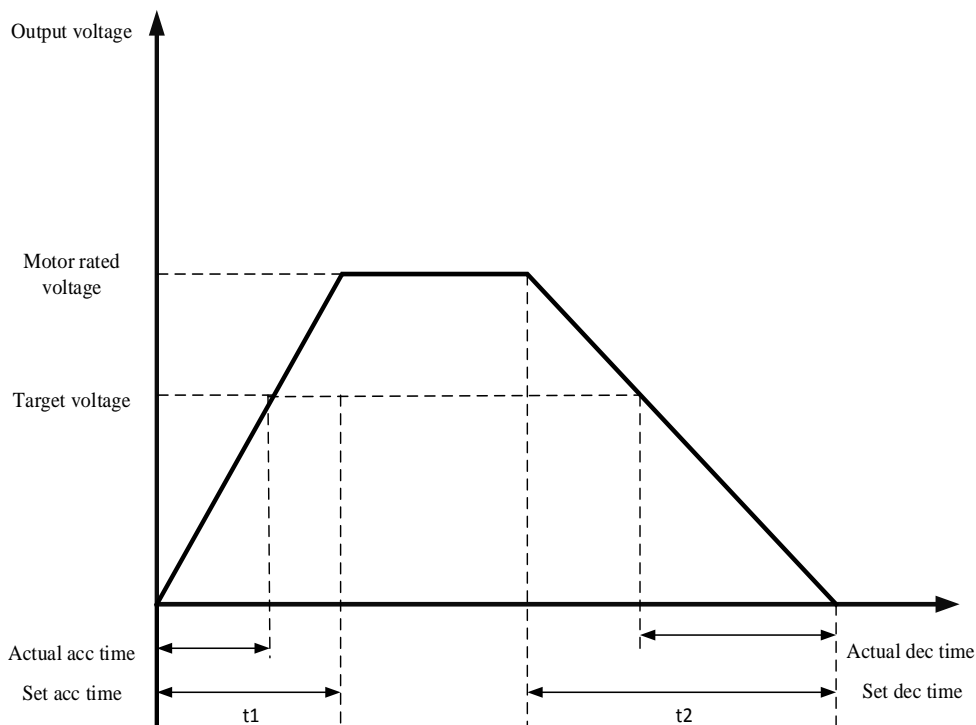



Parameter	Name	Range
P5-13	Stop mode of VF separation	0: Frequency voltage independently reduced to 0 1: When the voltage decreases to zero, the frequency begins to decrease

0: Frequency voltage independently reduced to 0

The output voltage of VF separation decreases to 0V according to the voltage drop time (P5-12). The output frequency of VF separation decreases to 0Hz according to deceleration time (P0-19).

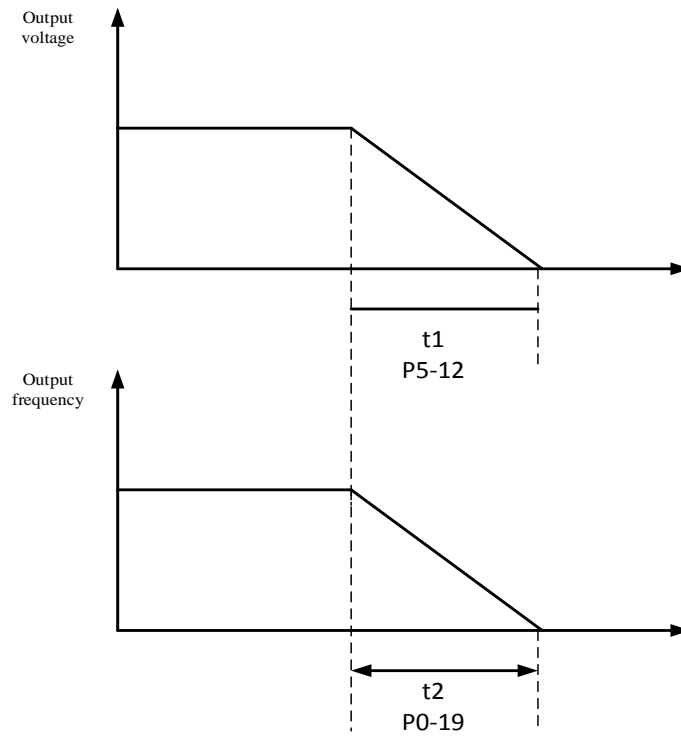

1: When the voltage decreases to zero, the frequency begins to decrease

The output voltage of VF separation first decreases to 0V according to the voltage drop time (P5-12), then the frequency decreases to 0Hz according to the deceleration time (P0-19).

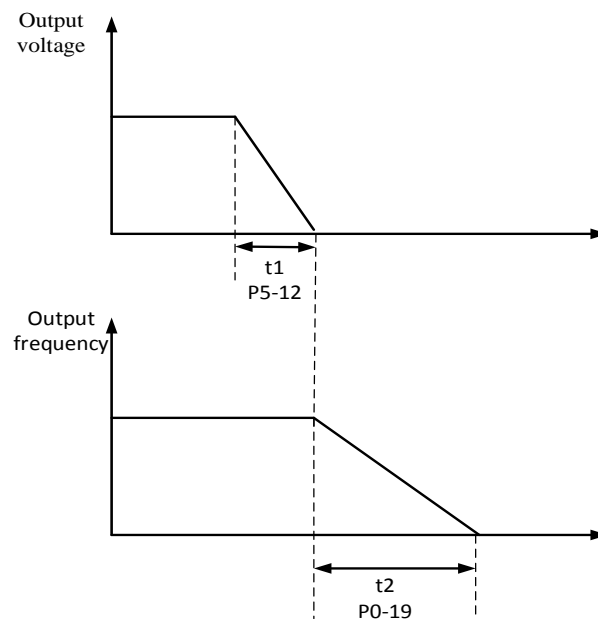

Parameter	Name	Range
P5-14	VF control slip compensation gain	0%~200%

This parameter is only effective for asynchronous motor, which compensates the motor speed deviation when the load increases, so that the motor speed can be basically stable when the load changes.

Parameter	Name	Range
P5-15	Slip compensation time constant	0.1~10.0s

The smaller the response time value of slip compensation is set, the faster the response speed is.

Parameter	Name	Range
P5-16	VF over excitation gain	0—200

In the process of inverter deceleration, the over excitation gain can inhibit the rise of bus voltage, but the larger the over excitation gain is, the larger the output current will increase. In the case of braking resistance or small inertia, which is not easy to produce overvoltage, it can be set to 0.

Parameter	Name	Range
P5-17	VF oscillation suppression gain	0—100

The gain is selected as small as possible on the premise of effectively suppressing the oscillation, so as to avoid adverse effects on VF operation. When there is no electrical oscillation, please set the gain to 0. Only when the motor oscillates obviously, the gain should be increased appropriately. The larger the gain is, the more obvious the suppression of oscillation is.

When using the function of suppressing oscillation, the parameters of rated current and no-load current should be accurate, otherwise the effect of VF oscillation suppression is not good.

Parameter	Name	Range
P5-18	VF oscillation suppression mode	0—4

Parameter	Name	Range
P5-19	VF over current stall action current	50%~200%
P5-20	VF over current stall suppression enable	0: invalid 1: valid
P5-21	VF over current stall suppression gain	0~100
P5-22	VF over current stall action current compensation coefficient	50%~200%

In the high frequency region, the motor drive current is small. Below the rated frequency, the speed of the motor drops greatly with the same stall current. In order to improve the operation characteristics of the motor, the stall action current above the rated frequency can be reduced. In some centrifuges with high operation frequency, several times weak magnetic field and large load inertia are required, this method has a good effect on acceleration performance.

transition stall action current over rated frequency =  $(f_s/f_n) * k * \text{LimitCur}$ ;

$f_s$  is running frequency,  $f_n$  is motor rated frequency,  $k$  is P5-22(Current compensation coefficient of double speed overcurrent stall action), LimitCur is P5-19(overcurrent stall action current).

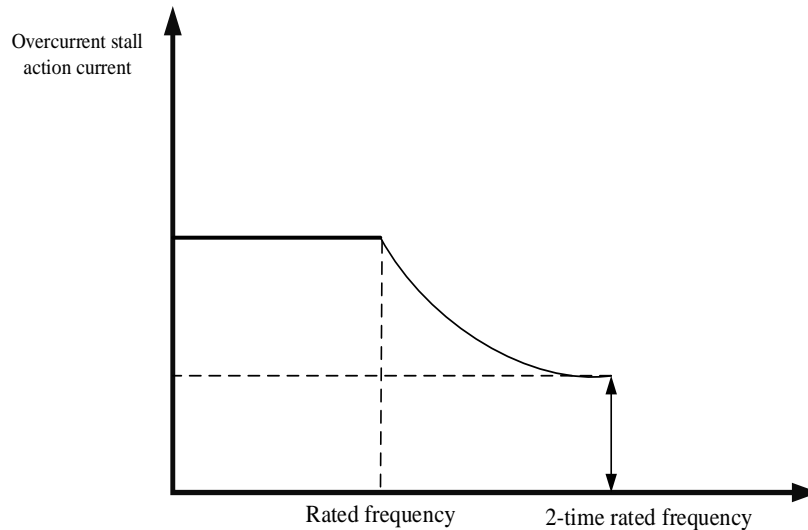

**Note:**

- (1) 150% of over-current stall action current means 1.5 times of rated current of frequency converter;
- (2) The carrier frequency of high-power motor is below 2kHz. Due to the increase of pulsating current, the wave by wave current limiting response precedes the over-current stall to prevent action starting, resulting in insufficient torque. In this case, please reduce the over-current stall to prevent action current.

Parameter	Name	Range
P5-23	Overvoltage stall action voltage	50%~200%
P5-24	Overvoltage stall suppression enable	0: invalid 1: valid
P5-25	Overvoltage stall suppression frequency gain	0~100
P5-26	Over voltage stall suppression voltage gain	0~100
P5-27	Over voltage stall maximum rise frequency limit	0~50Hz

When the motor speed is higher than the output speed, the motor is in the state of power generation. In order to suppress the continuous rise of bus voltage, the frequency inverter will adjust the output frequency to consume more electric energy. The actual deceleration time will be automatically extended to avoid tripping. If the actual deceleration time can not meet the requirements, the over excitation gain can be appropriately increased.

Note: when using the brake resistor: P5-16 (over excitation gain) is set to 0, otherwise it is easy to cause excessive current in operation; P5-24 (overvoltage stall enable) is set to 0, otherwise the deceleration time may be too long.

#### 4-2-7. Group P6 vector parameters

Parameter	Name	Range
P6-00	Speed loop proportional gain 1	1~100
P6-01	Speed loop integral time 1	0.01s~10.00s
P6-02	Speed loop proportional gain 2	1~100
P6-03	Speed loop integral time 2	0.01s~10.00s
P6-04	Switching frequency 1	0.00~P6-05
P6-05	Switching frequency 2	P6-05~max output frequency P0-13

Different PI parameters of speed loop can be selected when the inverter operates at different frequencies. When the operating frequency is less than the switching frequency 1 (P6-04), the PI regulation parameters of the speed loop are P6-00 and P6-01. When the operating frequency is greater than the switching frequency 2, the PI regulation parameters of the speed loop are P6-02 and P6-03. The PI parameters of speed loop between switching frequency 1 and switching frequency 2 are linear switching of two groups of PI parameters, as shown in the figure below:

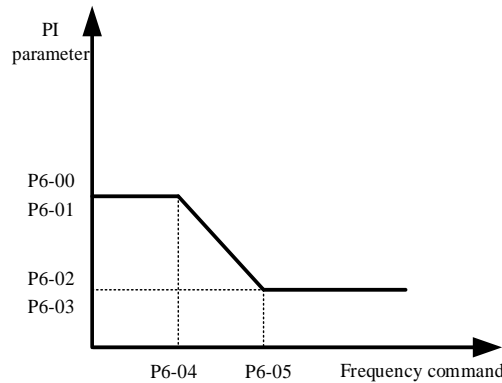

By setting the proportional coefficient and integral time of the speed regulator, the speed dynamic response characteristics of the vector control can be adjusted.

Increasing the proportional gain and decreasing the integration time can accelerate the dynamic response of the speed loop. Improper setting of PI parameters may lead to excessive speed overshoot. Even when the overshoot falls back, overvoltage fault occurs.

The recommended adjustment method is as follows:

If the factory parameters can not meet the requirements, fine-tuning should be carried out on the basis of the factory parameters. Firstly, the proportional gain should be increased to ensure that the system does not oscillate; Then, the integration time is reduced to make the system have faster response characteristics and smaller overshoot.

Parameter	Name	Range
P6-06	Speed loop integral attribute	Ones bit: 0: invalid 1: valid

Parameter	Name	Range
P6-07	Vector slip compensation gain	50%~200%

This parameter is used to adjust the steady speed accuracy of the motor: when the motor speed is low with load, the parameter will be increased, and vice versa.

For vector control with speed sensor, this parameter can adjust the output current of inverter with the same load.

Parameter	Name	Range
P6-08	SVC speed feedback filter time	0.000s~1.000s

The speed feedback filtering time of SVC takes effect only when P0-01 = 0. Increasing P6-08 can improve the stability of the motor, but the dynamic response becomes weak. On the contrary, the dynamic response becomes stronger, but too small will cause the motor vibration. In general, it no needs to adjust.

Parameter	Name	Range	
P6-10	Speed control (drive) torque upper limit source	0	Set by P6-11
		2	AI
		5	Communication setting
		Fault scale of 1~7 corresponds to P6-11	
P6-11	Speed control (drive) torque upper limit digital setting	0.0%~200.0%	

In speed control mode, the maximum output torque of the inverter is controlled by the torque upper limit source. P6-10 is used to select the setting source of torque upper limit. When setting through the analog quantity, communication, the corresponding setting 100% corresponds to P6-11, while the 100% of P6-11 corresponds to the rated output current of the converter.

The setting of AI is described in the relevant description of AI curve of group P2 (corresponding curve is selected through P2-54).

Parameter	Name	Range
P6-14	Excitation regulation proportional gain	0 ~ 60000
P6-15	Excitation regulation integral gain	0 ~ 60000
P6-16	Torque regulation proportional gain	0 ~ 60000
P6-17	Torque regulation integral gain	0 ~ 60000

The PI parameter of vector control current loop can be obtained automatically after the dynamic tuning of asynchronous motor, which generally does not need to be modified.

It should be noted that the integral regulator of the current loop does not use the integral time as the dimension, but directly sets the integral gain.

If the PI gain of current loop is too large, the whole control loop may oscillate. Therefore, when the current oscillation or torque fluctuation is large, the PI proportional gain or integral gain can be reduced manually.

#### 4-2-8. Group P7 fault and protection

Parameter	Name	Fault code
P7-00	Third (last) fault type	0~28
P7-01	Second fault type	
P7-02	First fault type	

Record the latest three fault types of frequency converter, 0 is no fault. For the possible causes and solutions of each fault code, please refer to the relevant fault description.

Parameter	Name	Fault code
P7-03	Frequency of the third fault	Frequency of last failure
P7-04	Current of the third fault	Current of last failure
P7-05	Bus voltage of the third fault	Bus voltage of last failure

P7-06	Input terminal state of the third fault	<p>The status of digital input terminal in the latest fault, the order is:</p> <table border="1"> <tr> <td>BIT9</td><td>BIT8</td><td>BIT7</td><td>BIT6</td><td>BIT5</td><td>BIT4</td><td>BIT3</td><td>BIT2</td><td>BIT1</td><td>BIT0</td> </tr> <tr> <td>X10</td><td>X9</td><td>X8</td><td>X7</td><td>X6</td><td>X5</td><td>X4</td><td>X3</td><td>X2</td><td>X1</td> </tr> </table> <p>When the input terminal is on, the corresponding binary bit is 1, and off is 0. The status of all X is converted to decimal number display.</p>	BIT9	BIT8	BIT7	BIT6	BIT5	BIT4	BIT3	BIT2	BIT1	BIT0	X10	X9	X8	X7	X6	X5	X4	X3	X2	X1
BIT9	BIT8	BIT7	BIT6	BIT5	BIT4	BIT3	BIT2	BIT1	BIT0													
X10	X9	X8	X7	X6	X5	X4	X3	X2	X1													
P7-07	Output terminal state of the third fault	<p>The status of digital output terminal in the latest fault, the order is:</p> <table border="1"> <tr> <td>BIT4</td><td>BIT3</td><td>BIT2</td><td>BIT1</td><td>BIT0</td> </tr> <tr> <td>Relay 2</td><td>Relay 1</td><td>Y3</td><td>Y2</td><td>Y1</td> </tr> </table> <p>When the output terminal is on, the corresponding binary bit is 1, and off is 0. The status of all Y is converted to decimal number display.</p>	BIT4	BIT3	BIT2	BIT1	BIT0	Relay 2	Relay 1	Y3	Y2	Y1										
BIT4	BIT3	BIT2	BIT1	BIT0																		
Relay 2	Relay 1	Y3	Y2	Y1																		
P7-08	VFD state of the third fault	Reserved																				
P7-09	The time of the third fault	Present power on time of the last fault																				
P7-10	The time of the third fault	Present operation time of the last fault																				
P7-13	The frequency of the second fault	Same to P7-03~P7-10																				
P7-14	The current of the second fault																					
P7-15	The bus voltage of the second fault																					
P7-16	Input terminal state of the second fault																					
P7-17	Output terminal state of the second fault																					
P7-18	VFD state of the second fault																					
P7-19	The time of the second fault																					
P7-20	The time of the second fault																					
P7-23	Frequency of the first fault		Same to P7-03~P7-10																			
P7-24	Current of the first fault																					
P7-25	Bus voltage of the first fault																					
P7-26	Input terminal state of the first fault																					
P7-27	Output terminal state of the first fault																					
P7-28	VFD state of the first fault																					
P7-29	The time of the first fault																					
P7-30	The time of the first fault																					

Parameter	Name	Range
P7-33	Motor overload protection mode selection	0: forbidden 1: Allowed
P7-34	Motor overload protection gain	0.20~10.00
P7-35	Motor overload warning coefficient	50%~100%

When P7-33 is set to 0, the motor has no overload protection function, it is recommended to install the heating

relay before the motor.

When P7-33 is set to 1, the inverter has the ability to protect the motor overload. Refer to P7-34 and P7-35 for protection settings.

In order to protect different load motors effectively, it is necessary to set the parameters according to the overload capacity of the motor. The inverse time limit curve of motor overload protection is shown in the figure below.

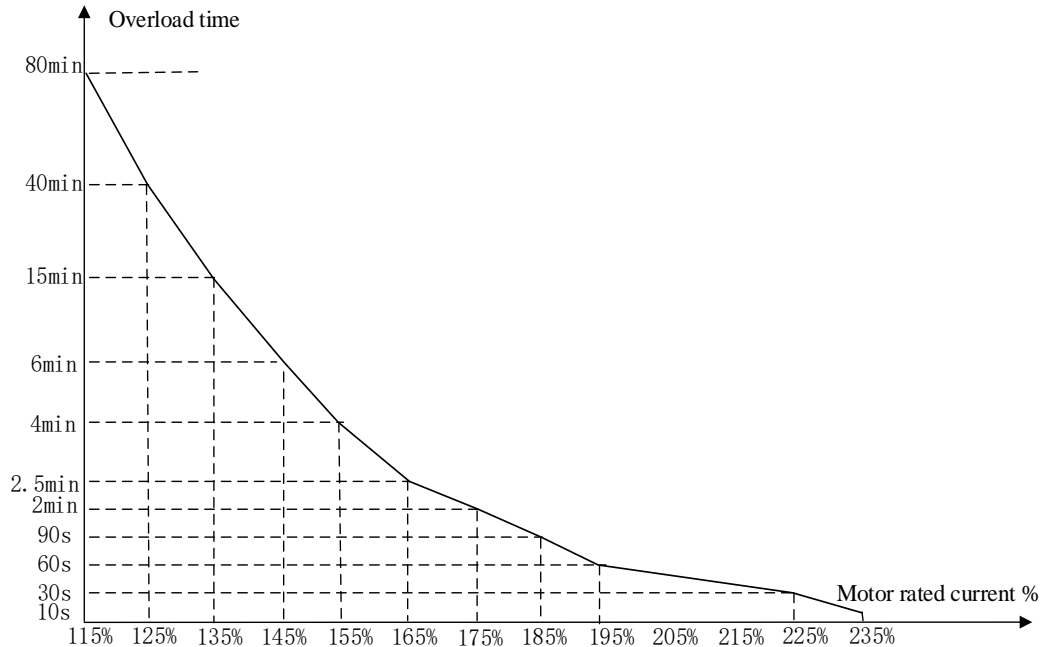

(1) When the running current of the motor reaches 175% times of the rated current of the motor, the motor overload (Err10) will be reported after continuous running for 2 minutes; When the running current of the motor reaches 115% of the rated current of the motor, the motor overload (Err10) will be reported after continuous operation for 80 minutes.

The maximum overload time is 80 minutes and the minimum overload time is 10 seconds.

(2) For example, motor overload protection adjustment: it is required that the motor should operate for 2 minutes under 150% motor current to report overload. According to the motor overload curve diagram, 150% (I) current is in the current range of 145% (I1) and 155% (I2), 145% of current is overloaded for 6 minutes (T1), 155% of current is overloaded for 4 minutes (T2), so the 150% overload of the rated current for 5 minutes under the default setting is calculated as follows:

$$T = T1 + (T2 - T1) * (I - I1) / (I2 - I1) = 4 + (6 - 4) * (150\% - 145\%) / (155\% - 145\%) = 5 \text{ minutes}$$

It can be concluded that the motor needs to report overload in 2 minutes under the condition of 150% motor current. Motor overload protection gain:  $P7-34 = 2 \div 5 = 0.4$

Note: the user needs to set the value of P7-34 correctly according to the actual overload capacity of the motor. If the parameter is set too large, it is easy to cause the motor overheating damage and the frequency converter does not alarm and protect in time!

Parameter	Name	Range
P7-36	Motor temperature sensor type	0: without temperature sensor 1: PT100
P7-37	Motor overheat protection threshold	0°C~100°C
P7-38	Motor overheat warning threshold	0°C~100°C

The temperature signal of the motor temperature sensor needs to be connected to the AI3 terminal of card slot A. The AI3 analog input terminal of VH5 supports PT100 temperature sensor. The motor temperature value is

displayed in U0-40.

When the motor temperature exceeds the motor overheat protection threshold P7-37, the inverter will give an alarm and deal with it according to the selected fault protection action mode.

When the motor temperature exceeds the motor overheat warning threshold P7-78, the inverter multi-function digital Y outputs the motor overheat warning ON signal.

Parameter	Name	Range
P7-39	Input phase lack protection	Ones bit: input phase lack protection Tens bit: Contactor closing protection selection 0: Forbidden 1: Allowed

Select whether to protect the input phase loss or contactor closing.

Parameter	Name	Range
P7-40	Output phase lack protection	0: Forbidden 1: Allowed

Choose whether to protect the output phase lack. If 0 is selected, the fault will not be reported when the actual output phase lack occurs. At this time, the actual current is larger than the current displayed on the panel. There is a risk. Please use it cautiously.

Parameter	Name	Range
P7-41	Power on short circuit to ground protection function	0: invalid 1: valid

When the frequency converter is powered on, it can detect whether the motor is short circuited to the ground. If this function is effective, the UVW end of the inverter will have voltage output for a period of time after power on.

Parameter	Name	Range
P7-42	Action selection of fault relay during automatic fault reset	0: no action 1: action

If the frequency converter is equipped with automatic fault reset function, fault Y action during automatic fault reset can be set through P7-42 (P7-42 is only effective for Y terminal).

Parameter	Name	Range
P7-43	Interval time of automatic fault reset	0.1s~60.0s

This parameter is used as the wait time from the fault occurrence to the automatic reset of the fault.

Parameter	Name	Range
P7-44	Fault automatic reset times	0~20

This parameter is used as the times of automatic reset after the failure of the frequency converter, and the frequency converter maintains the failure state after exceeding the set value.

Parameter	Name	Range
P7-45	Protection action 1 when fault	Ones bit: motor overload (Err 10) 0: free stop



Parameter	Name	Range
		1: stop as stop mode Tens bit: input phase lacking (Err11) 0: free stop 1: stop as stop mode Hundreds bit: output phase lacking (Err12) 0: free stop 1: stop as stop mode Thousands bit: output load drop (Err19) 0: free stop 1: stop as stop mode Ten thousand bit: pole position detection failed (Err21) 0: free stop 1: stop as stop mode
P7-46	Protection action 2 when fault	Ones bit: external fault 1 (Err43) 0: free stop 1: stop as stop mode Tens bit: communication error (Err44) 0: free stop 1: stop as stop mode Hundreds bit: EEPROM read write error (Err45) 0: free stop 1: stop as stop mode Thousands bit: operation time reached (Err46) 0: free stop 1: stop as stop mode Ten thousand bit: power on time reached (Err47) 0: free stop 1: stop as stop mode
P7-47	Protection action 3 when fault	Ones bit: user defined fault 1 (Err48) 0: free stop 1: stop as stop mode Tens bit: user defined fault 2 (Err49) 0: free stop 1: stop as stop mode Hundreds bit: PID feedback lost in operation (Err50) 0: free stop 1: stop as stop mode Thousands bit: speed deviation too large (Err52) 0: free stop

Parameter	Name	Range
		1: stop as stop mode Ten thousand bit: motor over speed (Err53) 0: free stop 1: stop as stop mode
P7-48	Protection action 4 when fault	Ones bit: motor overheat (Err54) 0: free stop 1: stop as stop mode

Parameter	Name	Range
P7-52	Braking start voltage	200.0~2000.0
P7-53	Braking service rate	0~100

When the bus voltage reaches the P7-52 setting value, the brake resistance starts to work, and the service rate of the brake resistance is adjusted through P7-53.

Parameter	Name	Range
P7-55	Over voltage stall gain	0~100
P7-56	Over voltage stall protection voltage	650V~800V

Parameter	Name	Range
P7-63	Over speed detection value	0.0%~50.0% (max frequency)
P7-64	Over speed detection time	0.0s~60.0s

This function is only effective when the inverter is running with speed sensor vector control.

When the frequency converter detects that the actual speed of the motor exceeds the maximum frequency, the exceeding value is greater than the over speed detection value P7-63, and the duration is greater than the over speed detection time P7-64, the frequency converter fault alarms Err53 and it shall be handled according to the action mode of fault protection.

When the over speed detection time is 0.0s, the over speed fault detection is cancelled.

Parameter	Name	Range
P7-65	Detection value of excessive speed deviation	0.0%~50.0% (max frequency)
P7-66	Detection time of excessive speed deviation	0.0s~60.0s

This function is only effective when the inverter is running with speed sensor vector control.

When the frequency converter detects that the actual speed of the motor deviates from the set frequency, the deviation is greater than the detection value P7-65, and the duration is greater than the detection time P7-66, the frequency converter fault alarms Err52 and it shall be handled according to the action mode of fault protection.

When the detection time of speed deviation is 0.0s, the fault detection of excessive speed deviation is cancelled.

Parameter	Name	Range
P7-67	Selection of instantaneous stop non-stop function	0: Transient power failure invalid 1: Deceleration in case of instantaneous power failure 2: Deceleration stop in case of instantaneous

		power failure
P7-68	Pause judgement voltage of transient stop action	80.0%~100.0%
P7-69	Judgment time of instantaneous stop non-stop voltage rising	0.0s~30.0s
P7-70	Judgement voltage of instantaneous stop non-stop action	60.0%~100.0% (standard bus voltage)
P7-71	Proportional gain of instantaneous stop non-stop	0~100
P7-72	Integral coefficient of instantaneous stop non-stop	0~100
P7-73	Deceleration time of instantaneous stop non-stop	0~300.0s

The purpose of instantaneous stop non-stop is to ensure that when the power supply of the power grid is abnormal, the motor can decelerate and stop normally, so that the motor can start immediately after the power supply of the power grid is restored, and it will not stop freely because of the sudden undervoltage fault when the power supply of the power grid is abnormal. In the large inertia system, it takes a long time for the motor to stop freely. When the power supply of the power grid is normal, because the motor is still rotating at high speed, it is easy to cause overload or over-current fault when starting the motor.

#### 4-2-9. Group P8 keyboard and display

Parameter	Name	Range
P8-00	JOG button function	0: Menu switching 1: Forward and reverse switching 2: Forward jog 3: Reverse jog

The jog key is a multi-function key, and the function of the multi-function key can be set through the function code. This key can be used to switch between shutdown and operation.

0: three display modes of function code are switched by multi-function button

1: Forward and reverse switching

Switch the direction of frequency command through the multi-function key. This function is only valid when the command source is the command channel of the operation panel.

2: Forward jog

Through the multi-function key to achieve forward jog.

3: Reverse jog through the multi-function key to achieve reverse jog.

Parameter	Name	Range
P8-01	STOP/REST function	0: Only in keyboard operation mode, STOP/REST key shutdown function is effective 1: In any operation mode, the STOP/REST key is effective

Parameter	Name	Range
P8-02	Parameter initialization	0: no operation 1: restore factory parameters, excluding motor parameters

		2: clear record information
--	--	-----------------------------

1. Restore factory settings, excluding motor parameters

After P8-02 is set to 1, most of the function parameters of the inverter are restored to the factory parameters, but the motor parameters are not restored.

2. Clear record information

Clear the inverter fault record information, cumulative operation time (P8-10), cumulative power on time (P8-11), cumulative power consumption (P8-12).

Parameter	Name	Range
P8-03	User password	0~65535

If any non-zero number is set in P8-03, the password protection function will take effect. The next time you enter the menu, you must input the password correctly, otherwise you can't view and modify the function parameters. Please remember the user password.

If P8-03 is set to 00000, the set user password will be cleared and the password protection function will be invalid.

Parameter	Name	Range
P8-05	Personalized parameter mode selection	Ones bit: 0: No display 1: Display user selected parameters Tens bit: 0: No display 1: Display user modified parameters

When P8-05=10, press JOG button to enter --C--, check the parameters modified by user.

When P8-05=01, press JOG button to enter --U--, check the parameters defined by user. User can select common parameters through group PE (PE-00~PE-31). Please refer to chapter 3-1-6 for details.

Parameter	Name	Range
P8-06	Read only user password	0: Modifiable 1: Not modifiable

Users can set whether the function code parameters can be modified to prevent the risk of function parameters being changed by mistake.

If the function code is set to 0, all function codes can be modified; When it is set to 1, all function codes can only be viewed and cannot be modified.

Parameter	Name	Range
P8-07	LED operation display parameter 1	0000 ~ FFFF
P8-08	LED operation display parameter 2	0000 ~ FFFF

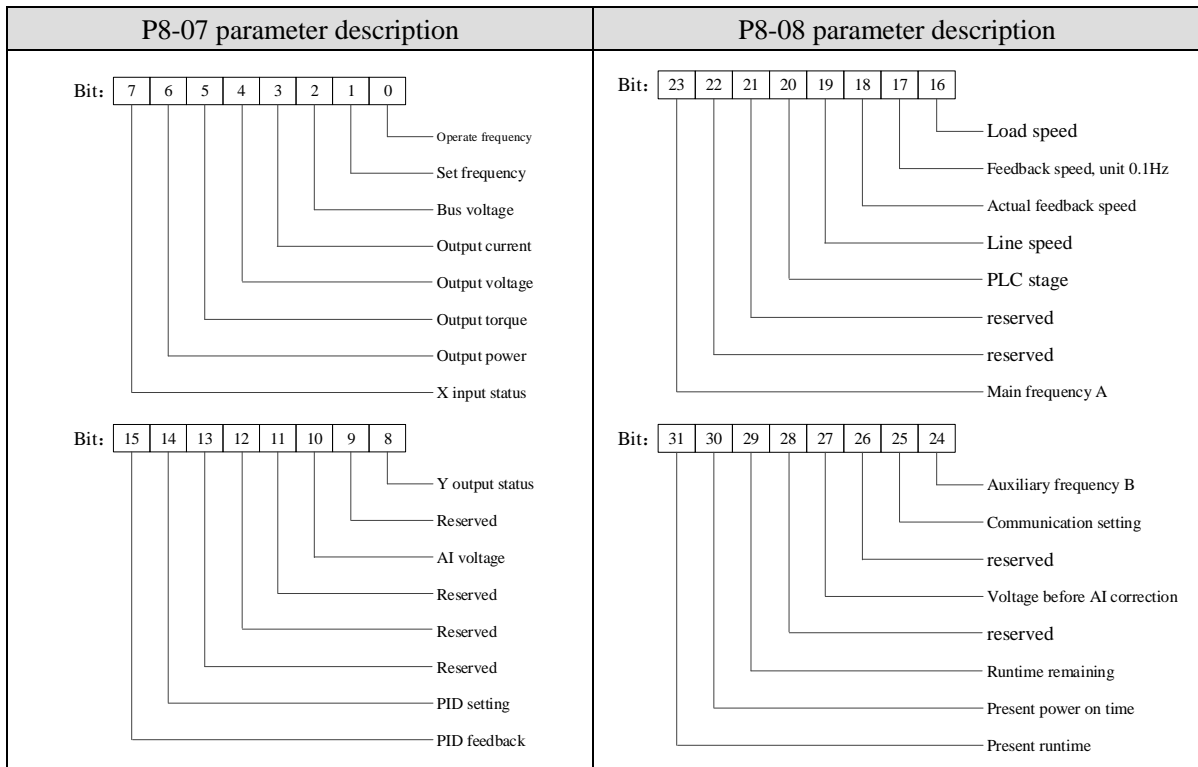

Parameter	Name	Range	Description
P8-09	LED shutdown display parameter	0000~FFFF	<p>Bit: 7 6 5 4 3 2 1 0</p> <ul style="list-style-type: none"> <li>Set frequency</li> <li>Bus voltage</li> <li>X input status</li> <li>Y output status</li> <li>reserved</li> <li>AI voltage</li> <li>reserved</li> <li>reserved</li> </ul> <p>Bit: 15 14 13 12 11 10 9 8</p> <ul style="list-style-type: none"> <li>PID setting</li> <li>Load speed</li> <li>PLCStep</li> <li>reserved</li> <li>reserved</li> <li>reserved</li> <li>reserved</li> <li>reserved</li> </ul>

In the shutdown or running state, multiple status parameters can be displayed by switching with the key  on the operation panel

There are 24 operation status parameters in operation status. If these parameters need to be displayed, the corresponding bit should be set to 1. After converting this binary number to hexadecimal number, it should be set to P8-07 and P8-08. Similarly, there are 8 shutdown status parameters in shutdown status. If these parameters need to be displayed, set their corresponding bits to 1, and set them to parameter P8-09 after converting binary numbers to hexadecimal.

Parameter	Name	Range
P8-10	Accumulated running time	0h~65535h

Display the accumulated running time of frequency converter. When the running time reaches the set running time PC-32, the multi-function digital output function of frequency converter outputs ON signal.

Parameter	Name	Range
P8-11	Cumulative power on time	0~65535 hours

Display the cumulative power on time of frequency converter since leaving factory.

When this time reaches the set power on time (PC-30), the multi-function digital output function of frequency converter outputs ON signal.

Parameter	Name	Range
P8-12	Cumulative power consumption	0~65535 degree

Display the cumulative power consumption of the inverter so far.

Parameter	Name	Range
P8-13	GP model display	1: type G (Constant torque load model) 2: type P (Fan and water pump load model)

This parameter is only used by the user to view the factory model, and cannot be changed.

1: It is suitable for constant torque load with specified rated parameters.

2: It is applicable to variable torque load (fan and water pump load) with specified rated parameters.

Parameter	Name	Range
P8-14	Product number	-
P8-15	Performance version no.	-
P8-16	Function version no.	-

Parameter	Name	Range
P8-19	Inverter module radiator temperature	0.0°C~100.0°C

Displays the temperature of IGBT inverter module.

Parameter	Name	Range
P8-20	Output power factor	00.00%~200.00%

When the output power (U0-06) does not correspond to the expected value, the output power can be linearly corrected by this value.

#### 4-2-10. Group P9 communication protocol

Parameter	Name	Range
P9-00	Communication protocol	0: Modbu-RTU 1: communication extension card
P9-01	Local address	1~247, 0 is broadcast address
P9-02	Baud rate	0: 300BPS 1: 600BPS 2: 1200BPS

		3: 2400BPS 4: 4800BPS 5: 9600BPS 6: 19200BPS 7: 38400BPS 8: 57600BPS
P9-03	MODBUS data format 1~4	0: no parity (8-N-2) 1: even parity (8-E-1) 2: odd parity (8-O-1) 3: no parity (8-N-1)

P9 group parameters are the communication parameters of this model. The necessary conditions for serial communication are communication protocol, local station number, baud rate and data format.

Parameter	Name	Range
P9-04	Communication timeout	0.0 s (invalid) 0.1 ~ 60.0s

When the function code is set to 0.0 s, the communication timeout parameter is invalid.

When the function code is set to a valid value, if the interval between one communication and the next exceeds the communication timeout, the system will report a communication timeout (Err44). Usually, it is set to invalid.

Parameter	Name	Range
P9-05	MODBUS response delay	0~20ms

Response delay: it refers to the interval between the end of data receiving of frequency converter and the sending of data to upper computer. If the response delay is less than the system processing time, the response delay is subject to the system processing time. If the response delay is longer than the system processing time, the system will wait until the response delay time reached, and then send the data to the upper computer.

#### 4-2-11. Group PA PID parameters of process control

Parameter	Name	Range
PA-01	Setting channel selection	0: PA-05 setting 2: AI 5: communication setting 6: multi-segment command setting
PA-02	Feedback channel selection	1: AI 6: communication setting

PA-01 is used to select the target given channel of process PID. PA-02 is used to select the feedback channel of process PID.

The setting target value of process PID is relative value, and the setting range is 0.0% ~ 100.0%. Similarly, the feedback quantity of PID is also relative quantity, and the goal of PID is to make the two relative quantities the same.

Note: when PA-01 is set to 6, PB-16 cannot be set to 5.

Parameter	Name	Range
PA-03	PID feedback filter time	0.00s~30.00s
PA-04	PID output filter time	0.00s~30.00s

PA-03 is used to filter the PID feedback, which is helpful to reduce the influence of the disturbance on the feedback, but it will lead to the degradation of the response performance of the process closed-loop system.

PA-04 is used to filter the PID output frequency, which will weaken the mutation of the inverter output frequency, but it will also lead to the degradation of the response performance of the process closed-loop system.

Parameter	Name	Range
PA-05	PID value setting	0.0%~100.0%

When PA-01 is set to 0, this parameter needs to set.

Parameter	Name	Range
PA-06	PID setting change time	0.00s~300.00s

The given change time of PID refers to the time required for the given value of PID to change from 0.0% to 100.0%.

When the given value of PID changes, the given value of PID changes linearly according to the given change time to reduce the adverse impact of the given mutation on the system.

Parameter	Name	Range
PA-07	PID reverse cut off frequency	0.00Hz~max output frequency

In some cases, only when the PID output frequency is negative (i.e. inverter reversal), PID can control the quantitative and feedback quantity to the same state, but the high reverse frequency is not allowed for some occasions, and PA-07 is used to determine the upper limit of reverse frequency.

When the frequency source is PID, the frequency output range is as follows:

For example: frequency source is pure PID or main + PID

(1) The reverse cutoff frequency is 0 (PA-07=0) or reverse is forbidden (P0-21=1). Output range: lower frequency to upper frequency (i.e. P0-17~P0-15).

(2) The reverse cut off frequency is not 0 and reverse running is not prohibited (PA-07≠0, P0-21=0). Output range: - reverse cut off frequency ~ upper limit frequency.

Parameter	Name	Range
PA-08	PID deviation limit	0.0%~100.0%

When the deviation between the given quantity and the feedback quantity of PID is less than PA-08, the PID stops adjusting. In this way, the output frequency is stable when the deviation between given and feedback is small, which is very effective for some closed-loop control situations.

Parameter	Name	Range
PA-09	PID differential limiting	0.00%~100.00%

In PID regulator, the function of differential is sensitive and easy to cause system oscillation. Therefore, the function of PID differential is generally limited to a small range. PA-09 is used to set the output range of PID differential.



Parameter	Name	Range
PA-10	Proportional gain P	0.0~100.0
PA-11	Integral time I	0.01s~10.00s
PA-12	Differential time D	0.000s~10.000s

Proportional gain P:

It determines the regulation intensity of the whole PID regulator. The greater the P is, the greater the regulation intensity is. The parameter 100.0 means that when the deviation between the PID feedback quantity and the given quantity is 100.0%, the adjustment amplitude of the PID regulator to the output frequency command is the maximum frequency.

Integral time T:

Determine the intensity of integral regulation of PID regulator. The shorter the integration time, the greater the adjustment intensity. The integral time means that when the deviation between PID feedback and given quantity is 100.0%, the integral regulator continuously adjusts the time and the adjustment quantity reaches the maximum frequency.

Differential time D:

Determine the strength of PID regulator deviation change rate. The longer the differential time is, the stronger the regulation is. Differential time means that when the feedback value changes by 100.0% in this time, the adjustment value of differential regulator is the maximum frequency.

Parameter	Name	Range
PA-13	PID parameter switching condition	0: do not switch 1: Switch through X terminal 2: Switch automatically according to deviation 3: Switch automatically according to the operation frequency
PA-14	PID parameter switching deviation 1	0.0%~PA-15
PA-15	PID parameter switching deviation 2	PA-14~100.0%

In some applications, a group of PID parameters can not meet the needs of the whole operation process, so different PID parameters need to be used in different situations. The parameters can be switched through the X terminal (function 35) of the multi-function terminal, or according to the deviation.

(1) Switch through multi-function terminal X

When switching through the function no.36 of the multi-function terminal, the terminal signal off corresponds to the first group of PID parameters, and the terminal signal ON corresponds to the second group of PID parameters;

(2) Automatic switching by deviation

When the absolute value of deviation between given and feedback is less than PID parameter switching deviation 1 (PA-14), the first group of PID parameters is selected for PID parameters; When the absolute value of deviation between given and feedback is greater than PID switching deviation 2 (PA-15), the second group of PID parameters is selected. When the deviation between given and feedback is between switching deviation 1 and switching deviation 2, PID parameters are linear interpolation values of two groups of PID parameters, as shown in the figure below.

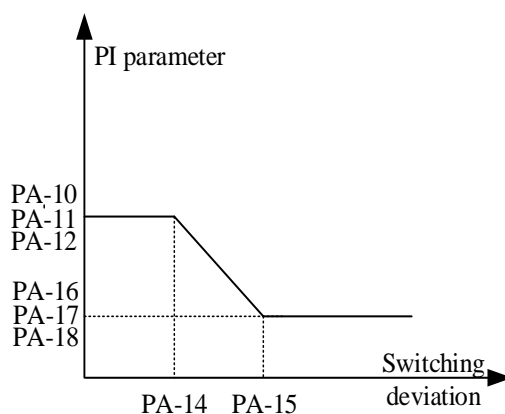

Parameter	Name	Range
PA-16	Proportional gain P2	0.0~100.0
PA-17	Integral time I2	0.01s~10.00s
PA-18	Differential time D2	0.000s~10.000s

Same to PA-10~PA-12, the second set of PID parameters.

Parameter	Name	Range
PA-19	PID action direction	0: positive action 1: negative action

Positive action: when the feedback signal of PID is less than the given quantity, the output frequency of frequency converter rises. Such as winding tension control occasions.

Negative action: when the feedback signal of PID is less than the given quantity, the output frequency of frequency converter decreases. Such as unwinding tension control occasions.

The function is affected by the reverse action direction of the multi-function terminal PID, which needs attention in use.

Parameter	Name	Range
PA-20	PID given feedback range	0~50000

PID given feedback range is a dimensionless unit, used for PID given display U0-14 and PID feedback display U0-15.

The relative value of the given feedback of PID is 100.0%, corresponding to the given feedback range PA-20.

For example, if PA-20 is set to 2000, when PID is given 100.0%, U0-14 is 2000.

Parameter	Name	Range
PA-21	PID maximum deviation between two outputs	0.00%~100.00%
PA-22	PID minimum deviation between two outputs	0.00%~100.00%

Parameter	Name	Range
PA-23	PID initial value	0.0%~100.0%
PA-24	PID initial value holding time	0.00s~500.00s

When the VFD is started, PID output is fixed to PID initial value PA-23, and PID does not start closed-loop adjustment operation until the initial value of PID is maintained for PA-24. The following figure shows the function diagram of the initial PID value.

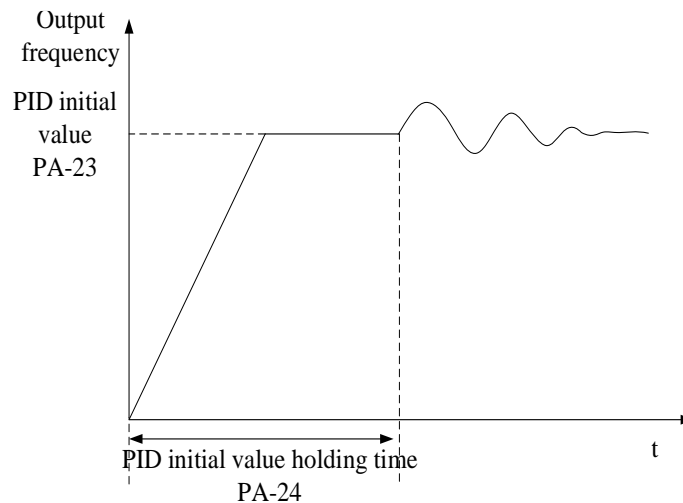

Parameter	Name	Range
PA-25	PID operation mode (whether to operate when shutdown)	0: not operate when shutdown 1: operate when shutdown

It is used to select whether the PID continues to calculate in PID shutdown state. In general application, PID should stop operation in shutdown state.

Parameter	Name	Range
PA-26	PID integral attribute	Ones bit: integral separation 0: invalid 1: valid Tens bit: whether to stop integration after output to limit value 0: continue to integral 1: Stop integral

Integral separation:

If the integral separation is set to be effective, when the X terminal integral pause (function 34) is effective, the integral of PID stops operation, and at this time, only the proportional and differential functions of PID are effective.

When the integral separation is invalid, the integral separation is invalid no matter whether the multi-function digital DI is valid or not.

Whether to stop integration after output reached limit value:

After the PID operation output reaches the maximum or minimum value, you can choose whether to stop the integral action. If stop integral is selected, PID integral calculation will stop at this time, which may help to reduce PID overshoot.

Parameter	Name	Range
PA-27	PID feedback lost detection value	0.0%: not judge the feedback lost 0.1%~100.0%
PA-28	PID feedback lost detection time	0.0s~30.0s

This function code is used to judge whether PID feedback is lost.

When the PID feedback value is less than the feedback loss detection value PA-27 and the duration exceeds the PID feedback loss detection time PA-28, the VFD will alarm the fault Err50.

#### 4-2-12. Group PB multi-speed and simple PLC

Parameter	Name	Range
PB-00	Multi-segment command 0	-100.0% ~ +100.0%
PB-01	Multi-segment command 1	-100.0% ~ +100.0%
PB-02	Multi-segment command 2	-100.0% ~ +100.0%
PB-03	Multi-segment command 3	-100.0% ~ +100.0%
PB-04	Multi-segment command 4	-100.0% ~ +100.0%
PB-05	Multi-segment command 5	-100.0% ~ +100.0%
PB-06	Multi-segment command 6	-100.0% ~ +100.0%
PB-07	Multi-segment command 7	-100.0% ~ +100.0%
PB-08	Multi-segment command 8	-100.0% ~ +100.0%
PB-09	Multi-segment command 9	-100.0% ~ +100.0%
PB-10	Multi-segment command 10	-100.0% ~ +100.0%
PB-11	Multi-segment command 11	-100.0% ~ +100.0%
PB-12	Multi-segment command 12	-100.0% ~ +100.0%
PB-13	Multi-segment command 13	-100.0% ~ +100.0%
PB-14	Multi-segment command 14	-100.0% ~ +100.0%
PB-15	Multi-segment command 15	-100.0% ~ +100.0%
PB-16	Multi-segment 0 command setting mode	0: PB-00 setting 2: AI 5: PID setting 6: preset frequency P0-10

According to the different states of multi-function digital X, the multi-segment instruction needs to be switched and selected. For details, please refer to the relevant instructions of group P2.

Parameter	Name	Range
PB-17	Simple PLC segment 0 operation time	0.0~6500.0s(h)
PB-18	Simple PLC segment 0 acc/dec time	0~3
PB-19	Simple PLC segment 1 operation time	0.0~6500.0s(h)
PB-20	Simple PLC segment 1 acc/dec time	0~3
PB-21	Simple PLC segment 2 operation time	0.0~6500.0s(h)
PB-22	Simple PLC segment 2 acc/dec time	0~3
PB-23	Simple PLC segment 3 operation time	0.0~6500.0s(h)
PB-24	Simple PLC segment 3 acc/dec time	0~3
PB-25	Simple PLC segment 4 operation time	0.0~6500.0s(h)
PB-26	Simple PLC segment 4 acc/dec time	0~3
PB-27	Simple PLC segment 5 operation time	0.0~6500.0s(h)
PB-28	Simple PLC segment 5 acc/dec time	0~3
PB-29	Simple PLC segment 6 operation time	0.0~6500.0s(h)
PB-30	Simple PLC segment 6 acc/dec time	0~3
PB-31	Simple PLC segment 7 operation time	0.0~6500.0s(h)
PB-32	Simple PLC segment 7 acc/dec time	0~3
PB-33	Simple PLC segment 8 operation time	0.0~6500.0s(h)
PB-34	Simple PLC segment 8 acc/dec time	0~3

Parameter	Name	Range
PB-35	Simple PLC segment 9 operation time	0.0~6500.0s(h)
PB-36	Simple PLC segment 9 acc/dec time	0~3
PB-37	Simple PLC segment 10 operation time	0.0~6500.0s(h)
PB-38	Simple PLC segment 10 acc/dec time	0~3
PB-39	Simple PLC segment 11 operation time	0.0~6500.0s(h)
PB-40	Simple PLC segment 11 acc/dec time	0~3
PB-41	Simple PLC segment 12 operation time	0.0~6500.0s(h)
PB-42	Simple PLC segment 12 acc/dec time	0~3
PB-43	Simple PLC segment 13 operation time	0.0~6500.0s(h)
PB-44	Simple PLC segment 13 acc/dec time	0~3
PB-45	Simple PLC segment 14 operation time	0.0~6500.0s(h)
PB-46	Simple PLC segment 14 acc/dec time	0~3
PB-47	Simple PLC segment 15 operation time	0.0~6500.0s(h)
PB-48	Simple PLC segment 15 acc/dec time	0~3

Parameter	Name	Range
PB-49	Simple PLC operation mode	0: stop at the end of single operation 1: Keep the final value at the end of single operation 2: cycle all the time

Simple PLC function has two functions: as a frequency source or as a voltage source of VF separation.

When simple PLC is used as frequency source, the positive and negative values of PB-00 ~ PB-15 determine the operation direction. If the value is negative, it means that the inverter runs in the opposite direction.

As a frequency source, PLC has three operation modes, but as a VF voltage source, it has no such mode. Among them:

0: Stop at the end of single operation

The inverter stops automatically after completing a single cycle and needs to give the operation command again to start.

1: Keep the final value at the end of single operation

After completing a single cycle, the frequency and direction of the last section will be maintained automatically.

2: Cycle all the time

After the inverter completes one cycle, it will start the next cycle automatically until there is a stop command.

The figure below is the schematic diagram of simple PLC as frequency source. When simple PLC is used as frequency source, the positive and negative values of PB-00 ~ PB-15 determine the operation direction. If the value is negative, it means that the inverter runs in the opposite direction.

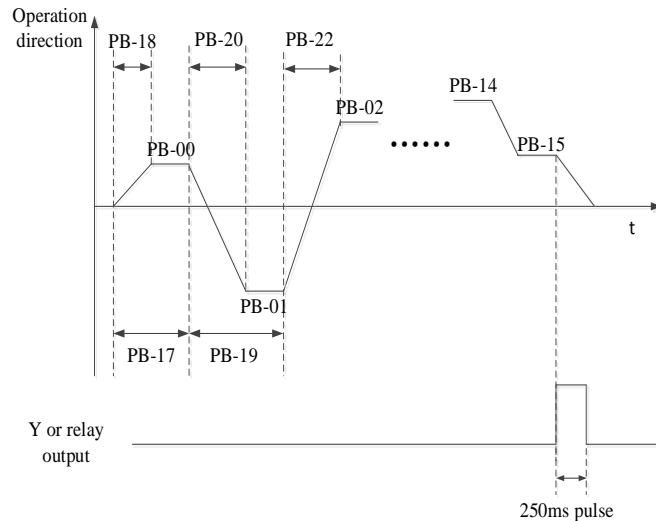

Parameter	Name	Range
PB-50	Simple PLC operation time unit	0: second 1: hour

Parameter	Name	Range
PB-51	Simple PLC power-off memory selection	Ones bit: power-off memory 0: not memory 1: memory Tens bit: stop memory 0: not memory 1: memory

PLC power down memory refers to memorizing the operation stage and frequency of PLC before power down, and continuing to run from the memory stage when next power on. If no memory is selected, the PLC process will be restarted every time when the power is on.

PLC shutdown memory is to record the previous PLC operation stage and frequency during shutdown, and continue to run from the memory stage during the next operation. If no memory is selected, the PLC process will be restarted every time.

#### 4-2-13. Group PC auxiliary function

Parameter	Name	Range
PC-00	Jog frequency	0.00Hz~max frequency
PC-01	Jog acceleration time	0.0s~6500.0s
PC-02	Jog deceleration time	0.0s~6500.0s

Define the given frequency and acceleration and deceleration time of frequency converter when jogging. During jog operation, the start mode is fixed as direct start mode (P4-00 = 0), and the stop mode is fixed as deceleration stop mode (P4-22 = 0).

Parameter	Name	Range
PC-03	acceleration time 2	0.1s~6500.0s
PC-04	deceleration time 2	0.1s~6500.0s
PC-05	acceleration time 3	0.1s~6500.0s

PC-06	deceleration time 3	0.1s~6500.0s
PC-07	acceleration time 4	0.1s~6500.0s
PC-08	deceleration time 4	0.1s~6500.0s

VH5 provided four groups of acceleration and deceleration time, which are P0-18/P0-19 and above parameters.

Parameter	Name	Range
PC-09	The unit of acc/dec time	0: 1s 1: 0.1s 2: 0.01s

PC-09 is used to set the unit of acceleration and deceleration time for four groups.

Parameter	Name	Range
PC-10	The base frequency of acc/dec time	0: max frequency 1: setting frequency 2: 50Hz

The acceleration and deceleration time is the time accelerating from 0 to the frequency set by PC-10. If PC-10 is 1, the acceleration of the motor changes.

Parameter	Name	Range
PC-11	Switching frequency point between acceleration time 1 and acceleration time 2	0.00Hz~max frequency
PC-12	Switching frequency point between deceleration time 1 and deceleration time 2	0.00Hz~ max frequency

When controlling motor 1, you can choose different acceleration and deceleration time.

Note: when using this function, the multi-function terminal function cannot select the acceleration and deceleration time switching.

Parameter	Name	Range
PC-13	Jump frequency 1	0.00Hz~max frequency
PC-14	Jump frequency 2	0.00Hz~max frequency
PC-15	Jump frequency range	0.00Hz~max frequency

When the set frequency is within the range of jumping frequency, the actual running frequency will run at the jumping frequency close to the set frequency. By setting the jumping frequency, the inverter can avoid the mechanical resonance point of the load.

VH5 can set two jump frequency points. If both jump frequencies are set to 0, the jump frequency function will be cancelled.

Please refer to the figure below for the principle of jump frequency and jump frequency amplitude.

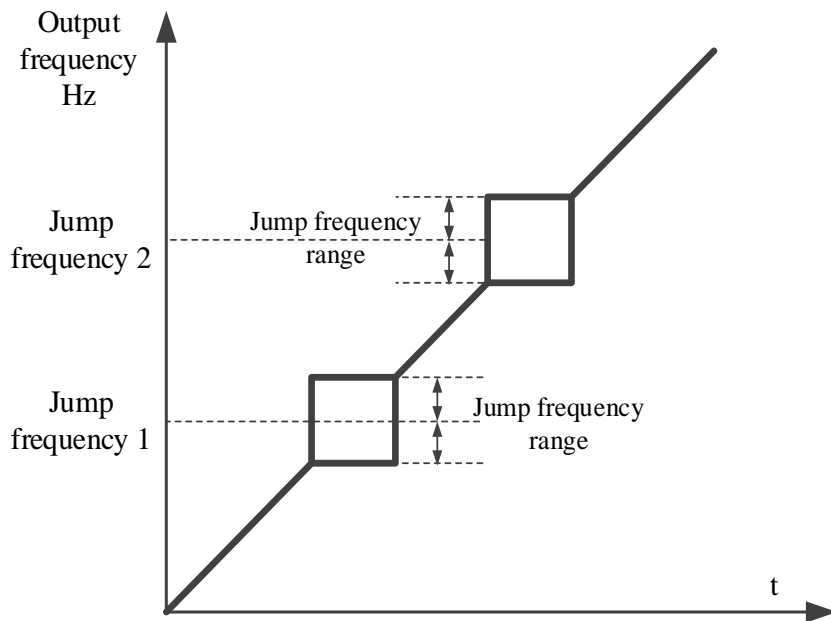

Parameter	Name	Range
PC-16	Whether the jump frequency is effective during acceleration and deceleration	0: invalid 1: valid (in vector condition)

Set whether the jump frequency is effective during acceleration and deceleration.

Parameter	Name	Range
PC-17	The frequency reached detection range	0.00~100% (max frequency)

When the operation frequency of the frequency converter is in a certain range of the target frequency, the multi-function Y terminal of the frequency converter outputs ON signal.

This parameter is used to set the detection range of frequency, which is the percentage relative to the maximum frequency. The figure below is the schematic diagram of frequency arrival.



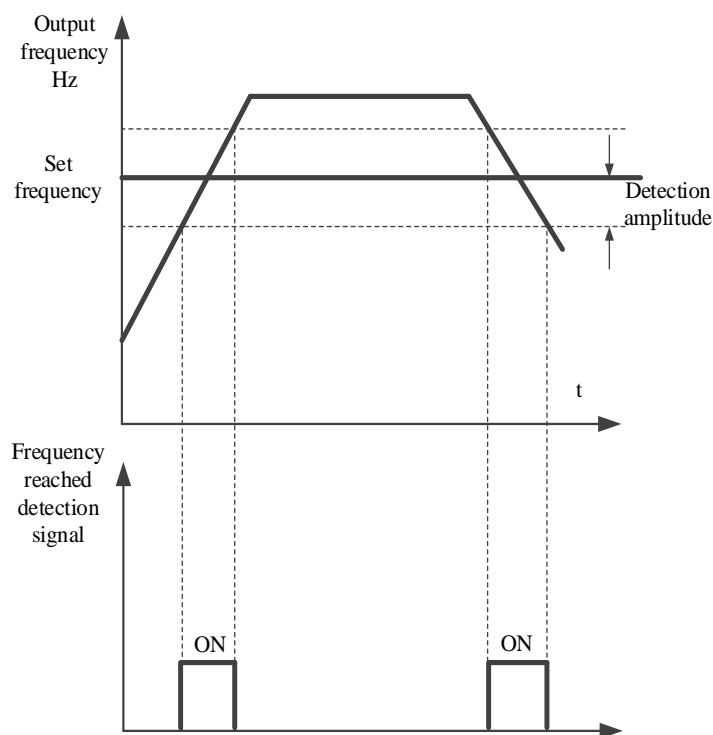

Parameter	Name	Range
PC-18	Frequency detection value (FDT1 voltage level)	0.00Hz~max frequency
PC-19	Frequency detection hysteresis value (FDT1 voltage level)	0.0%~100.0% (FDT1 level)

When the operating frequency is higher than the frequency detection value, the inverter multi-function output Y outputs ON signal, and when the frequency is lower than the detection value, the Y terminal output ON signal is cancelled.

The above parameters are used to set the detection value of output frequency and the hysteresis value of output action release. Where PC-19 is the percentage of the hysteresis frequency relative to the frequency detection value PC-18.

Parameter	Name	Range
PC-20	Frequency detection value (FDT2 voltage level)	0.00Hz~max frequency
PC-21	Frequency detection hysteresis value (FDT2 voltage level)	0.0%~100.0% (FDT1 level)

The frequency detection function is the same as that of FDT1. Please refer to the relevant description of function code PC-18 and PC-19.

Parameter	Name	Range
PC-22	Frequency reached detection value 1	0.00Hz~ max output frequency
PC-23	Frequency reached detection 1 range	0.0%~100.0% (max output frequency)
PC-24	Frequency reached detection value 2	0.00Hz~ max output frequency
PC-25	Frequency reached detection 2 range	0.0%~100.0% (max output frequency)

When the output frequency of the frequency converter is within the positive and negative detection range of frequency detection value, the multi-function Y outputs the ON signal.

VH5 provides two groups of frequency reached detection parameters, setting frequency value and frequency

detection range respectively. The figure below is the schematic diagram of this function.

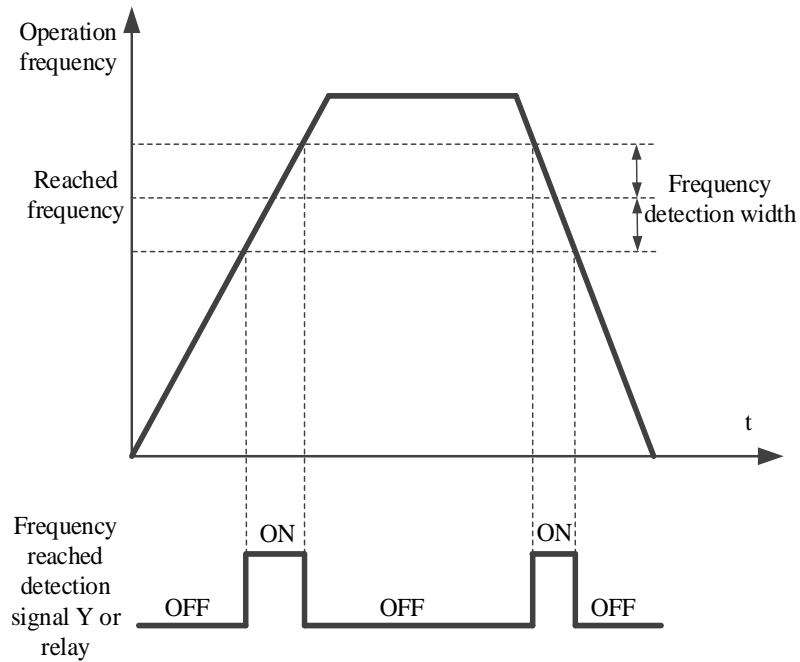

Parameter	Name	Range
PC-26	Timing function selection	0: invalid 1: valid
PC-28	Setting operation time	0.0Min~6500.0Min
PC-29	Present operation reached time	0.0Min~6500.0Min

When PC-26 = 1, the timing function is turned on, the current running time U0-31 is greater than the value set by PC-28, the inverter stops running, and Y outputs ON signal by assigning function code 26 to Y terminal. The value of current time U0-31 is greater than the value set by PC-29. By assigning function code 41 to Y terminal, Y outputs ON signal, but the inverter will not stop running.

Parameter	Name	Range
PC-30	Setting power on reached time	0~6500.0h
PC-32	Setting operation reached time	0~6500.0h

When the accumulated operation time of P8-10 is greater than the set operation arrival time of PC-32, the frequency converter will stop operation. By assigning function code 29 to the Y terminal, the Y terminal will output ON signal.

When the cumulative power on time of P8-11 is greater than the power on arrival time set by PC-30, the inverter will stop running. By assigning function code 25 to the Y terminal, the Y terminal will output ON signal.

Parameter	Name	Range
PC-34	Current reached detection value 1	0.0%~300.0% (motor rated current)
PC-35	Current reached detection 1 range	0.0%~300.0% (motor rated current)
PC-36	Current reached detection value 2	0.0%~300.0% (motor rated current)
PC-37	Current reached detection 2 range	0.0%~300.0% (motor rated current)

When the output current of the frequency converter is within the set positive and negative detection width of

current arrival, the multi-function Y outputs ON signal.

VH5 provides two groups of arrival current and detection width parameters. The following figure is the function diagram.

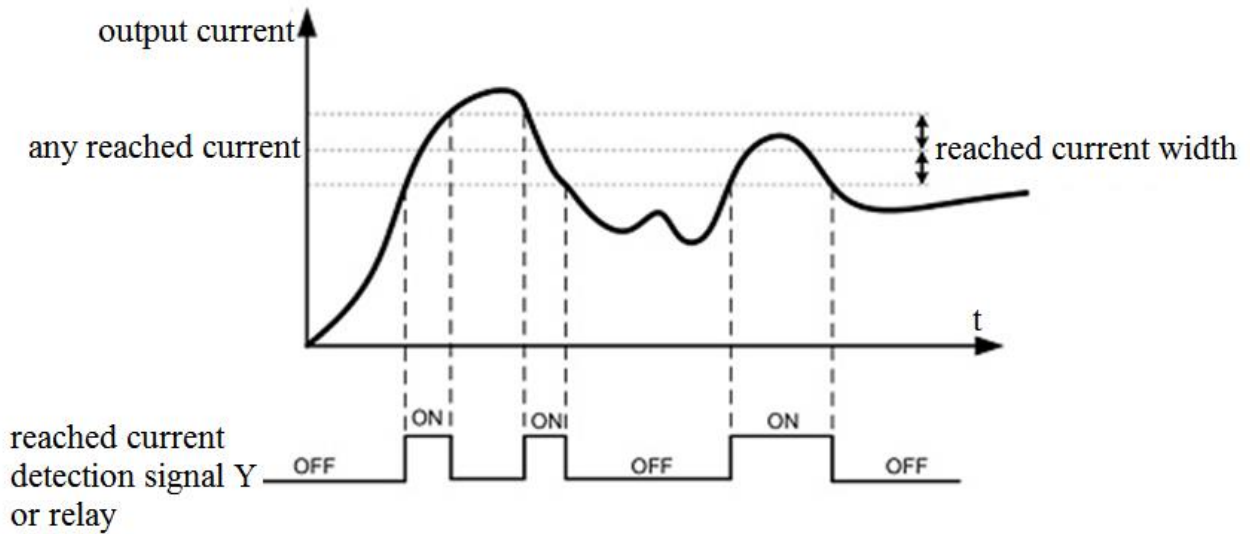

Parameter	Name	Range
PC-38	Zero current detection value	0.0%~300.0% (motor rated current)
PC-39	Zero current detection delay time	0.01s~600.00s

When the output current of the inverter is less than or equal to the zero current detection level and the duration exceeds the zero current detection delay time, the Y terminal of the inverter outputs ON signal.

Parameter	Name	Range
PC-40	Software overcurrent point	0: 0.0% (not detect) 1: 0.1%~300.0% (motor rated current)
PC-41	Software overcurrent detection delay time	0.00s~600.00s

When the output current of the frequency converter is greater than or exceeds the limit detection point, and the duration exceeds the software over-current point detection delay time, the Y terminal of the frequency converter outputs ON signal.

Parameter	Name	Range
PC-42	AI input voltage lower limit	0.00V~PC-43
PC-43	AI input voltage upper limit	PC-42~10.50V

When the value of analog input AI is greater than PC-43, or AI1 input is less than PC-42, Y terminal of frequency converter outputs "AI input overrun" ON signal, which is used to indicate whether the input voltage of AI is within the set range.

Parameter	Name	Range
PC-44	Over voltage point	200~810V (380V models) 200~400V (220 models)

It is used to set the voltage value of inverter overvoltage fault. The factory value of 380V voltage level inverter overvoltage point is 810V, and the factory value of 220V voltage level inverter overvoltage point is 400V.

Parameter	Name	Range
PC-45	Under voltage point	100~537V (380V models) 100~310V (220 models)

It is used to set the voltage value of inverter under voltage fault Err08 fault. The factory default value is 200V.

Parameter	Name	Range
PC-46	Operation action when the frequency is lower than lower limit frequency	0: run at lower limit frequency 1: stop 2: run at zero speed

Parameter	Name	Range
PC-47	Module temperature reached	0~100°C

When the inverter radiator temperature reaches the temperature, the inverter Y terminal outputs the "module temperature reaches" ON signal.

Parameter	Name	Range
PC-48	Fan control	0: The fan runs during operation 1: The fan is running all the time

It is used to select the action mode of the cooling fan. When 0 is selected, the fan runs in the running state of the inverter. When the radiator temperature is higher than 40°C, the fan runs. When the radiator temperature is lower than 40 °C, the fan does not run.

When it is selected as 1, the fan will run after power on.

Parameter	Name	Range
PC-49	Droop control	0.00Hz~10.00Hz

The droop rate allows a small speed difference between the master station and the slave station, thus avoiding conflicts between them. The default value for this parameter is 0.

Only when the master and slave adopt the speed control mode, the droop rate needs to be adjusted. For each transmission process, the appropriate droop rate needs to be gradually found in practice. It is suggested that the PC-49 should not be set too large, otherwise the steady-state speed will drop obviously when the load is large.

The droop rate must be set for both the master and slave.

$$\text{Droop speed} = \text{Synchronization frequency} \times \text{output torque} \times \text{droop rate} \div 10$$

Eg.: PC-49 = 1.00, Synchronization frequency=50Hz, output torque=50%, then

$$\text{Droop speed} = 50\text{Hz} \times 50\% \times 1.00 \div 10 = 2.5\text{Hz}$$

$$\text{VFD actual frequency} = 50\text{Hz} - 2.5\text{Hz} = 47.5\text{Hz}$$

Parameter	Name	Range
PC-50	Terminal jog run priority	0: invalid 1: valid

This parameter is used to set whether the terminal jog function has the highest priority.

When the terminal jog priority is effective, if the terminal jog command appears in the operation process, the inverter will switch to the terminal jog operation state.

Parameter	Name	Range
PC-51	SVC optimization selection	1: Optimization mode 1 2: Optimization mode 2

The SVC optimization mode of asynchronous motor, it does not need to be adjusted generally.

Parameter	Name	Range
PC-52	Dead area compensation mode	0: No compensation 1: Compensation mode 1

Parameter	Name	Range
PC-54	Modulation mode	0: Asynchronous Modulation 1: Synchronous modulation

It is only effective for VF control.

Synchronous modulation means that the carrier frequency changes linearly with the output frequency transformation to ensure that the ratio (carrier wave ratio) remains unchanged. It is generally used when the output frequency is higher, which is conducive to the quality of output voltage. When the output frequency is lower (below 100Hz), generally synchronous modulation is not needed, because the ratio of carrier frequency to output frequency is higher, and the advantage of asynchronous modulation is more obvious.

When the operating frequency is higher than 85Hz, the synchronous modulation will take effect, and the asynchronous modulation mode is adopted below this frequency.

Parameter	Name	Range
PC-55	DPWM switching upper limit frequency	5.00Hz~max output frequency

It is only effective for VF control. Generally, it does not need to be modified.

The modulation mode of asynchronous motor is determined by the VF wave generation mode. When the value is lower than PC-55, the switching loss of inverter is large, but the current ripple is small; When it is larger than PC-55, it is opposite, but it is easy to cause unstable operation of motor at high frequency.

When VF control operation is unstable, please refer to parameter P5-17. For inverter loss and temperature rise, please refer to PC-67.

Parameter	Name	Range
PC-56	Random PWM	0: Random PWM invalid 1~10: PWM carrier frequency random depth

When the random PWM depth is set to 0, the random PWM is invalid.

By adjusting the random PWM depth, the monotonous and harsh sound of the motor can be softened and the external electromagnetic interference can be reduced.

Parameter	Name	Range
PC-57	Wake up frequency	Dormancy frequency PC-58~max output frequency P0-13
PC-58	Dormancy frequency	0.00Hz~wake up frequency PC-57
PC-59	Wake up delay time	0.0s~6500.0s
PC-60	Dormancy delay time	0.0s~6500.0s

This set of parameters is used to realize the sleep and wake-up function in water supply application.

During the operation of the inverter, when the set frequency is less than or equal to the sleep frequency of

PC-58, after the delay time of PC-60, the inverter enters the sleep state and stops automatically.

If the inverter is in sleep state and the current operation command is valid, when the set frequency is greater than or equal to the PC-57 wake-up frequency, the inverter starts to restart after the PC-59 delay time.

In general, please set the wake-up frequency to be greater than or equal to the sleep frequency. Set the wake-up frequency and sleep frequency to 0.00hz, then the sleep and wake-up functions are invalid.

Note: when the sleep function is enabled, if the frequency source uses PID, it is necessary to select the operation when the PID stops (PA-52 = 1).

Parameter	Name	Range
PC-61	Wave by wave current limiting enable	0: Not enable 1: Enable

The fast current limiting function can minimize the over-current fault of the inverter and ensure the uninterrupted operation of the inverter.

If the frequency converter is in the fast current limiting state for a long time, the frequency converter may be damaged by overheating, which is not allowed. Therefore, when the frequency converter is in the fast current limiting state for a long time, it will give an alarm, indicating that the frequency converter is overloaded and needs to be shut down.

Parameter	Name	Range
PC-62	Current detection compensation	0~100

It is used to set the current detection compensation of frequency converter. If the setting is too large, the control performance may be degraded. Generally, it does not need to be modified.

Parameter	Name	Range
PC-65	Bus voltage reached value	Unit: 0.1V
PC-66	The bus voltage reached hysteresis value	Unit: 0.1V

When the bus voltage reaches (PC-65-PC-66~PC-65+PC66), the Y terminal outputs ON signal by assigning function code 42 to Y terminal.

Parameter	Name	Range
PC-67	Carrier frequency	0.5K~16.0K

By adjusting the carrier frequency of the inverter, the noise of the motor can be reduced, the resonance point of the mechanical system can be avoided, the line leakage current to the ground and the interference of the inverter can be reduced. When the carrier frequency is high, the motor loss and the motor temperature rising decrease, but the inverter loss increases, the inverter temperature rising increases, and the interference increases.

If the carrier frequency is set higher than the factory value, the temperature rising of the inverter radiator will be increased. At this time, the user needs to use the inverter derating.

Parameter	Name	Range	
PC-68	The carrier frequency is adjusted with temperature	0	No
		1	Yes

When PC-68 is 0, the carrier of frequency converter is determined by the set value and will not change during operation.

When PC-68 is 1, when the operating process of the inverter detects that the temperature of its radiator is high, the carrier frequency will be automatically reduced to reduce the temperature rising of the converter. When the temperature of the radiator is detected to be low, the carrier frequency will automatically return to the set value.

#### 4-2-14. Group PE user optional parameters

Parameter	Name	Range
PE-00	User optional parameters 0	P0.00 ~ PF.xx A0.00 ~ A2.xx A9.00 ~ Ad.xx U0.00 ~ U0.xx U4.00 ~ U5.xx
PE-01	User optional parameters 1	
PE-02	User optional parameters 2	
PE-03	User optional parameters 3	
PE-04	User optional parameters 4	
PE-05	User optional parameters 5	
PE-06	User optional parameters 6	
PE-07	User optional parameters 7	
PE-08	User optional parameters 8	
PE-09	User optional parameters 9	
PE-10	User optional parameters 10	
PE-11	User optional parameters 11	
PE-12	User optional parameters 12	
PE-13	User optional parameters 13	
PE-14	User optional parameters 14	
PE-15	User optional parameters 15	
PE-16	User optional parameters 16	
PE-17	User optional parameters 17	
PE-18	User optional parameters 18	
PE-19	User optional parameters 19	
PE-20	User optional parameters 20	
PE-21	User optional parameters 21	
PE-22	User optional parameters 22	
PE-23	User optional parameters 23	
PE-24	User optional parameters 24	
PE-25	User optional parameters 25	
PE-26	User optional parameters 26	
PE-27	User optional parameters 27	
PE-28	User optional parameters 28	
PE-29	User optional parameters 29	
PE-30	User optional parameters 30	
PE-31	User optional parameters 31	

This group of function codes is the user-defined parameter group (P8-00 is set to 0 and P8-05 is set to 11, used together).

Users can select the required parameters to be summarized into PE group in all VH5 function codes, which can be used as user-defined parameters to facilitate the operation of viewing and changing.

PE group provides up to 32 user-defined parameters. When entering user-defined parameter mode, the display function code is defined by PE-00~PE-31, and the sequence is consistent with PE group function code.

This parameter array can map some discontinuous parameters into PE parameters. When the upper computer PLC reads the parameters of the converter, it can read all the discontinuous parameters through one instruction, which can simplify the PLC communication instruction and improve the communication efficiency.

#### 4-2-15. Group PF torque control

Parameter	Name	Range
PF-00	Torque control	0: speed control 1: torque control

It is used to select the control mode of frequency converter: speed control or torque control, which cannot be switched during the operation of frequency converter.

The X terminal of VH5 has a function related to torque control: torque control inhibition (function 29).

When the speed control / torque control switching terminal is invalid, the control mode is determined by PF-00.

If the speed control / torque control switching is effective, the control mode is equivalent to the reverse value of PF-00.

Parameter	Name	Range
PF-01	Upper limit source of driver torque	0: digital setting 2: AI 5: communication setting (the full scale of option 1-7 correspond to PF-02 digital setting)
PF-02	Driver torque upper limit	-200.0%~200.0%

PF-01 is used to select the torque setting source. There are eight torque setting modes.

The torque setting adopts relative value, and 100.0% corresponds to the rated torque of the motor. The setting range is - 200.0% ~ 200.0%, indicating that the maximum torque of the inverter is twice the rated torque of the inverter.

When the torque is set to be positive, the frequency converter runs forward; When the given torque is negative, the inverter runs in reverse.

The torque setting sources are described as follows:

0: digital setting (PF-02)

The target torque directly uses the PF-02 setting value.

2: AI

When AI is set as frequency, the current/voltage input corresponds to the percentage of PF-02. The input voltage values of AI and the corresponding relationship curve with the target torque can be freely selected by the user through P2-54.

VH5 provides 5 groups of corresponding relationship curves, among which 3 groups of curves are linear relationship (2-point corresponding relationship), and 2 groups of curves are broken lines of 4-point corresponding relationship. Users can set them through P2 group.

5: Communication given

The target torque is given by the communication mode.

When MODBUS is used for communication, the data is given by the host computer through the communication address H1000, and the data format is data with 2 decimal places.

Parameter	Name	Range
PF-03	Torque control forward direction max frequency	0.00Hz~max output frequency
PF-04	Torque control reverse direction max frequency	0.00Hz~ max output frequency

It is used to set the forward or reverse maximum operating frequency of frequency converter under torque



control mode. The acceleration and deceleration time of upper frequency limit is set in PC-07 (acceleration) / PC-08 (deceleration).

When the inverter torque control, if the load torque is less than the motor output torque, the motor speed will continue to rise, in order to prevent the mechanical system from galloping accidents, we must limit the maximum speed of the motor in torque control.

If the maximum frequency of torque control needs to be dynamically changed continuously, it can be realized by controlling the upper limit frequency.

Parameter	Name	Range
PF-05	Torque acceleration time	0.00s~650.00s
PF-06	Torque deceleration time	0.00s~650.00s

Under the torque control mode, the difference between the output torque and the load torque determines the speed change rate of the motor and the load. The motor speed may change rapidly, causing noise or mechanical stress too much. By setting the torque control acceleration and deceleration time, the motor speed can change smoothly.

In the torque control of small torque starting, it is not recommended to set the torque acceleration and deceleration time. If the torque acceleration and deceleration time is set, it is suggested to increase the speed filter coefficient properly. When torque quick response is needed, torque control acceleration and deceleration time is set to 0.00s.

For example, two motors in hard connection drive the same load. In order to ensure the load distribution evenly, one frequency converter is set as the main machine, and the speed control mode is adopted, the other is slave and torque control is adopted. The actual output torque of the host machine is the torque command of the slave. At this time, the torque of the slave needs to follow the host quickly, Then the acceleration and deceleration time of torque control of slave is 0.00s.

#### 4-2-16. Group A0 fixed length, counting and swing frequency

Parameter	Name	Range
A0-00	Setting length	0m~65535m
A0-01	Actual length	0m~65535m
A0-02	Pulse per meter	0.1~6553.5

The above parameters are used for fixed length control.

In the application, it is necessary to set the corresponding input terminal function as "length counting input" (function 20). When the pulse frequency is high, the X4 port must be used. The actual length A0-01 can be calculated by dividing the number of pulses sampled by terminals and A0-02. When the actual length is greater than the set length A0-00, the multi-function digital Y outputs the "length reached" ON signal. In the process of fixed length control, the length reset operation (function 21) can be carried out through the multi-function X terminal.

Parameter	Name	Range
A0-03	Setting counting value	1~65535
A0-04	Specified counting value	1~65535

In application, the corresponding input terminal function should be set to "counter input" (function 22), and X4 port must be used when the pulse frequency is high.

When the count value reaches the set count value A0-03, the multi-function terminal Y outputs the "set count value arrival" ON signal, and then the counter stops counting. When the count value reaches the specified count

value A0-04, the multi-function terminal Y outputs the "specified count value arrival" ON signal, and the counter continues to count until the counter stops counting when the "set count value" reached.

Parameter	Name	Range
A0-05	Swing frequency setting mode	0: relative to center frequency 1: relative to the max frequency

This parameter is used to determine the reference value of swing.

0: relative to the center frequency (P0-03 frequency source), variable swing range system. The swing varies with the center frequency (set frequency).

1: relative to the maximum frequency (P0-13) is a constant swing range system with fixed swing range.

Parameter	Name	Range
A0-06	Swing frequency amplitude	0.0%~100.0%
A0-07	Jump frequency amplitude	0.0%~50.0%
A0-08	Swing frequency period	0.1s~3000.0s
A0-09	Triangular rise time of swing frequency	0.1%~100.0%

A0-06 swing amplitude AW:

When setting swing range relative to center frequency (A0-05 = 0),  $AW = \text{frequency source P0-03} \times \text{amplitude A0-06}$ . When setting swing range relative to maximum output frequency (A0-05 = 1),  $AW = \text{maximum output frequency P0-13} \times \text{swing range PB-21}$ .

A0-08 swing period: the time value of a complete swing period.

A0-07 jump frequency amplitude:

The jump frequency amplitude is the frequency percentage of the jump frequency relative to the swing range when the swing frequency is running, that is:  $\text{jump frequency} = AW \times \text{jump frequency amplitude A0-07}$ .

If the swing is relative to the center frequency (A0-05 = 0), the jump frequency is a changing value. If the swing is relative to the maximum output frequency (A0-05 = 1), the jump frequency is a fixed value. The swing operating frequency is constrained by the upper and lower limit frequencies.

A0-09 triangle wave rise time coefficient: it is the time percentage of triangle wave rise time relative to swing period A0-08.

Triangle wave rise time (s) = swing period A0-08  $\times$  rise time coefficient of triangular wave A0-09;

Triangle wave falling time (s) = swing period A0-08  $\times$  (1 - triangular wave rise time coefficient A0-09).

#### 4-2-17. Group A1 virtual IO

Parameter	Name	Range
A1-00	Function selection of virtual X1 terminal	Same as physical X terminal function setting
A1-01	Function selection of virtual X2 terminal	
A1-02	Function selection of virtual X3 terminal	
A1-03	Function selection of virtual X4 terminal	
A1-04	Function selection of virtual X5 terminal	

Parameter	Name	Range
A1-05	Virtual X terminal effective state source	Ones bit: virtual X1 0: the state of virtual Y1 determines whether virtual X1 is valid 1: Function code A1-06 sets whether virtual X1 is valid Tens bit: virtual X2 Hundreds bit: virtual X3 Thousands bit: virtual X4 Ten thousands bit: virtual X5
A1-06	Virtual X terminal status setting	0: invalid 1: valid Tens bit: virtual X1 Tens bit: virtual X2 Hundreds bit: virtual X3 Thousands bit: virtual X4 Ten thousands bit: virtual X5

Different from ordinary digital input terminal, virtual X can be set in two ways, and can be selected through A1-05.

When X state is determined by the state of corresponding virtual Y, whether X is valid depends on whether Y output is valid or invalid, and X is uniquely bound to Y<sub>x</sub> (X is 1 ~ 5).

When virtual X terminal status is set by function code, the status of virtual input terminal is determined by binary bit of function code A1-06. The following is an example of how to use the virtual X terminal.

Example 1: when virtual Y state is selected to determine virtual X state, to complete the following functions: when AI1 input exceeds the upper and lower limits, the frequency converter will give an alarm and shut down.

The following setting methods can be adopted:

Set the function of virtual X as "user defined fault 1" (A1-00 = 38).

The virtual X terminal effective state mode is determined by virtual Y (A1-05 = xxx0); Set the output function of virtual Y1 as "AI1 input exceeds the upper and lower limits" (A1-11 = 23).

When the AI1 input exceeds the upper and lower limits, the virtual Y1 output is in the ON state. At this time, the virtual X1 input terminal state is valid. The virtual X1 of the frequency converter receives the user-defined fault 1, and the frequency converter will alarm Err48 and shut down.

Example 2: when the function code A1-06 is selected to set the virtual X1 state, the following functions are completed: after the inverter is powered on, it will automatically enter the operation state. The following setting method can be adopted:

Set the function of virtual X1 to "forward running" (A1-00=1);

Set the valid status mode of virtual X1 terminal as function code (A1-05=xxx1);

Set the virtual X1 terminal status to be valid (A1-06=xxx1); Set the command source to terminal control (P0-02=1);

Set the start protection to "unprotected" (P4-05=0);

After the inverter power on is completed, it is detected that virtual X1 is effective, and the terminal is forward running, which is equivalent to the frequency converter receiving a terminal forward running command, and the inverter will start to run forward.

Parameter	Name	Range
A1-08	Function selection of AI terminal as X terminal	Same to the function settings of X terminal
A1-10	Selection of effective mode when AI is used as X terminal	Ones bit: AI 0: high level valid 1: low level valid

This group of function codes is used to use AI as X. When AI is used as X, if AI input voltage is greater than 7V, AI terminal status is high level. If AI input voltage is lower than 3V, AI terminal status is low level. There is hysteresis between 3V and 7V.

A1-10 is used to determine whether the AI high level is valid or the AI low level is valid when AI is X.

Parameter	Name	Range
A1-11	Virtual Y1 output function selection	0: connect with physical Xx inside 1~42: same to physical Y output
A1-12	Virtual Y2 output function selection	
A1-13	Virtual Y3 output function selection	
A1-14	Virtual Y4 output function selection	
A1-15	Virtual Y5 output function selection	
A1-16	Virtual Y1 output delay time	0.0s~3600.0s
A1-17	Virtual Y2 output delay time	0.0s~3600.0s
A1-18	Virtual Y3 output delay time	0.0s~3600.0s
A1-19	Virtual Y4 output delay time	0.0s~3600.0s
A1-20	Virtual Y5 output delay time	0.0s~3600.0s
A1-21	Virtual Y terminal effective state selection	Ones bit: virtual Y1 0: positive logic 1: negative logic Tens bit: virtual Y2 Hundreds bit: virtual Y3 Thousands bit: virtual Y4 Ten thousands bit: virtual Y5

Virtual digital output function is similar to Y output function of control board. It can be used to cooperate with virtual digital input X to realize some simple logic control.

When the output function of virtual Y is selected as 0, the output states of virtual Y1 ~ Y5 are determined by the input states of physical X1 ~ X5 on the control board. At this time, virtual Y corresponds to physical X.

When the virtual Y output function is not 0, the function setting and use method of virtual Y1 are the same as those of P3 group Y output. Please refer to the description of P3 group Y output.

#### 4-2-18. Group A2 second motor parameters

VH6 provides two sets of motor control parameters, which can set motor nameplate parameters, encoder parameters and VF vector performance parameters respectively.

Group A2 function code corresponds to motor 2. All parameters and application methods of group A2 are the same as those of motor 1, which will not be repeated here.

Parameter	Name	Range
A2-00	Motor type selection	0: Common asynchronous motor
A2-01	Motor rated power	0.1kW~650.0kW
A2-02	Motor rated voltage	1V~1200V

Parameter	Name	Range
A2-03	Motor rated current	0.01A~655.35A (VFD power ≤55kW) 0.1A~6553.5A (VFD power >55kW)
A2-04	Motor rated frequency	0.01Hz~max output frequency
A2-05	Motor rated speed	1rpm~65535rpm
A2-06	Asynchronous motor stator resistance	0.001Ω~65.535Ω (VFD power ≤55kW) 0.0001Ω~6.5535Ω (VFD power >55kW)
A2-07	Asynchronous motor rotor resistance	0.001Ω~65.535Ω (VFD power ≤55kW) 0.0001Ω~6.5535Ω (VFD power >55kW)
A2-08	Leakage inductance of asynchronous motor	0.01mH~655.35mH (VFD power ≤55kW) 0.001mH~65.535mH (VFD power >55kW)
A2-09	asynchronous motor mutual inductance	0.01mH~655.35mH (VFD power ≤55kW) 0.001mH~65.535mH (VFD power >55kW)
A2-10	asynchronous motor current without load	0.01A~P1-03 (VFD power ≤55kW) 0.1A~P1-03 (VFD power >55kW)
A2-32	Polar logarithm of rotation	1~65535
A2-33	Speed feedback PG disconnection detection time	0.0~10.0 (0.0: speed feedback disconnection detection ineffective)
A2-35	Motor 2 parameter self-learning	0: No operation 1: Static self-learning of asynchronous motor (some parameters) 2: Self-learning of asynchronous motor rotation
A2-36	Motor 2 control mode	0: VF control 1: no speed sensor vector control (SVC)
A2-37	Motor 2 acc/dec time selection	0: same to first motor 1: acceleration and deceleration time 1 2: acceleration and deceleration time 2 3: acceleration and deceleration time 3 4: acceleration and deceleration time 4
A2-38	Motor 2 torque boost	0.0%: Automatic torque boost 0.1%~30.0%
A2-40	Motor 2 oscillation suppression gain	0~100
A2-41	Speed loop proportion gain 1	1~100
A2-42	Speed loop integral time 1	0.01s~10.00s
A2-43	Speed loop proportion gain 2	1~100
A2-44	Speed loop integral time 2	0.01s~10.00s
A2-45	Switching frequency 1	0.00~P6-05
A2-46	Switching frequency 2	P6-05~max output frequency (P0-13)
A2-47	Speed loop integral property	Ones bit: integral separation 0: invalid 1: valid
A2-48	Slip gain of vector control	50%~200%

Parameter	Name	Range
A2-49	SVC speed feedback filter time	0.000s~1.000s
A2-51	Torque upper limit source under speed control mode	0: parameter setting (P6-11) 2: AI 5: communication setting
A2-52	Digital setting of torque upper limit in speed control mode	0.0%~200.0%
A2-55	Proportional gain of excitation regulation	0~60000
A2-56	Integral gain of excitation regulation	0~60000
A2-57	Torque regulation proportional gain	0~60000
A2-58	Integral gain of torque regulation	0~60000

#### 4-2-19. Group AD AIAO correction parameters

Parameter	Name	Range
AD-04	AI measured voltage 1	0.500V~4.000V
AD-05	AI display voltage 1	0.500V~4.000V
AD-06	AI measured voltage 2	6.000V~9.999V
AD-07	AI display voltage 2	6.000V~9.999V

This group of function codes is used to correct the analog input AI to eliminate the influence of bias and gain of the analog input.

This group of function parameters have been corrected before leaving the factory, and when the factory value is restored, it will return to the factory corrected value. Generally, there is no need for correction in the application site.

The measured voltage refers to the actual voltage measured by the multimeter and other measuring instruments, and the displayed voltage refers to the voltage display value sampled by the frequency converter. See the voltage (U0-27) before AI correction of U0 group.

When correcting, input two voltage values at each AI input port, and input the values measured by the multimeter and the values read by U0 group into the above function code, then the inverter will automatically correct the AI bias and gain.

For the case that the user given voltage and the actual sampling voltage of the converter do not match, the field correction method can be adopted to make the sampling value of the converter consistent with the expected value. The field correction method is as follows:

Given AI voltage signal (about 2V)

The actual measurement of AI voltage value is saved in AD-04, U0-27 is saved in AD-05.

Given AI voltage signal (about 8V)

The actual measurement of AI voltage value is saved in AD-06, U0-27 is saved in AD-07.

Parameter	Name	Range
AD-12	AO target voltage 1	0.500V~4.000V
AD-13	AO measured voltage 1	0.500~4.000V
AD-14	AO target voltage 2	6.000V~9.999V

AD-15	AO measured voltage 2	6.000V~9.999V
-------	-----------------------	---------------

This group of function codes is used to correct the AO of analog output to eliminate the influence of bias and gain of analog output.

This group of function parameters have been corrected before leaving the factory, and when the factory value is restored, it will return to the factory corrected value. Generally, there is no need for correction in the application site.

#### 4-2-20. Group U0 monitor parameters

Parameter	Name	Min unit
U0-00	Operation frequency (Hz)	0.01Hz
U0-01	Setting frequency (Hz)	0.01Hz
U0-02	Bus voltage (V)	0.1V
U0-03	Output current (A)	0.01A
U0-04	Output voltage (V)	1V
U0-05	Output torque (%) Percentage output value of motor rated torque	0.1%
U0-06	Output power (kW)	0.1kW
U0-07	X input state	1
U0-08	Y output state	1
U0-10	AI voltage (V)/current (mA)	0.01V/0.01mA
U0-14	PID setting	1
U0-15	PID feedback	1
U0-16	Load speed display	1
U0-17	Feedback speed (Hz)	0.01Hz
U0-18	Actual feedback speed (Hz)	0.01Hz
U0-19	Line speed	1m/Min
U0-20	PLC stage	1
U0-21	Count value	1
U0-22	Length value	1
U0-23	Main frequency A display	0.01Hz
U0-24	Auxiliary frequency B display	0.01Hz
U0-25	Communication setting	0.01%
U0-27	AI voltage before calibration (V)/current (mA)	0.001V/0.01mA
U0-29	Remaining running time	0.1Min
U0-30	Present power on time	1Min
U0-31	Present operation time	0.1Min
U0-32	VFD state	1
U0-33	Present fault	1
U0-34	Fault information	1
U0-35	Target torque (%)	0.1%
U0-36	Torque upper limit	0.01%
U0-37	Synchronous motor rotor position	1
U0-38	Rotation position	1
U0-39	ABZ position	1
U0-40	Motor temperature	1°C

Parameter	Name	Min unit
U0-41	Power factor angle	0.1°
U0-42	Setting frequency (%)	0.01%
U0-43	Operation frequency (%)	0.01%
U0-44	VF separate target voltage	1V
U0-45	VF separate output voltage	1V
U0-46	Z signal counter	1
U0-47	Motor serial number	0: motor 1 1: motor 2
U0-48	Check any memory address value	1
U0-65	Sending value of point-to-point communication	0.01%
U0-66	Slave machine number	1
U0-74	Motor actual output torque	-300% ~ 300%



# 5. EMC

## 5-1. EMC compliant installation guidelines

The output of the inverter is PWM wave, which will produce electromagnetic noise when it works. In order to reduce the interference of the inverter to the outside world, this section introduces the installation method of EMC in noise suppression, field wiring, grounding, leakage current, power filter use and so on.

### 5-1-1. Noise suppression

- Noise type

The noise generated by the operation of the frequency converter may affect the nearby instruments and equipment. The degree of influence is related to the control system of the frequency converter, the anti-noise ability of the equipment, the wiring environment, the safe distance, the grounding method and other factors. The types of noise include: electrostatic induction, circuit transmission, space transmission, electromagnetic induction, etc.

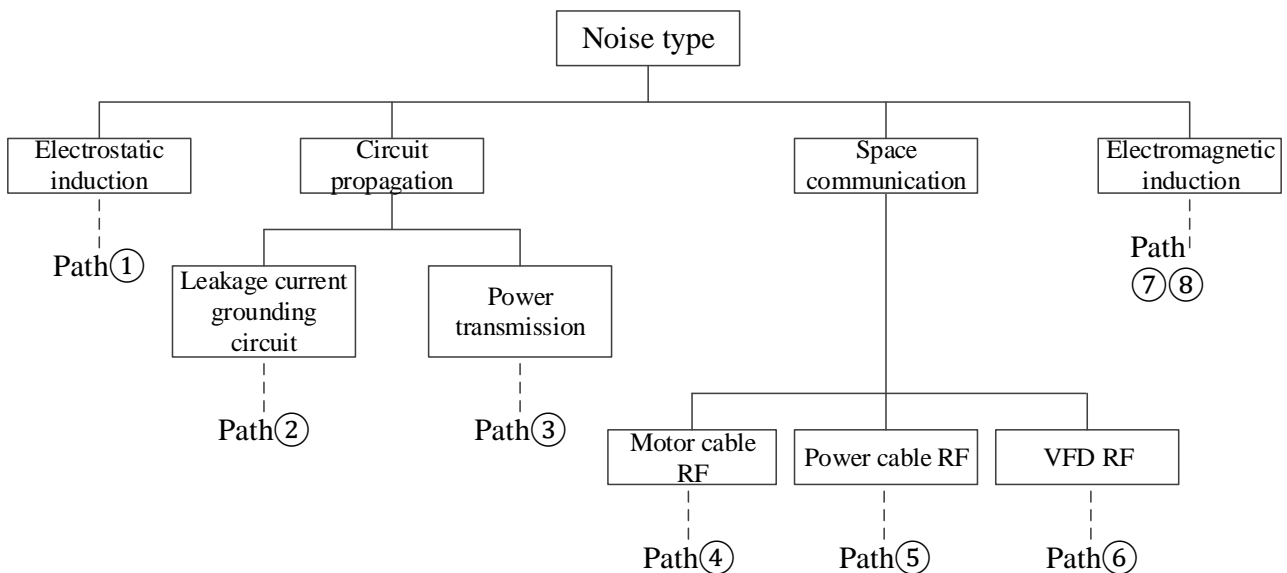

- Basic countermeasures for noise suppression

Noise propagation path	Solution
②	When the grounding wire of peripheral equipment and the wiring of frequency converter form a closed loop, the leakage current of the inverter grounding wire will cause the equipment to misbehave. At this time, if the equipment is not grounded, it will reduce the misoperation.
③	When the power supply of peripheral equipment and the power supply of frequency converter share the same system, the noise generated by the frequency converter propagates against the power line, which will disturb other equipment in the same system. The following measures can be taken to suppress the noise: installing electromagnetic noise filter at the input end of the frequency converter. Use isolation transformer or power filter to isolate other equipment.
④⑤⑥	(1) Equipment and signal lines that are easy to be disturbed should be installed as far away from

	<p>the frequency converter as possible. The signal line should use shielded wire, the shielding layer should be single ended grounding, and should be as far away from the inverter and its input and output lines as possible. If the signal wire must intersect with the strong current cable, the two should be kept orthogonal.</p> <p>(2) High frequency noise filters (ferrite common mode choke) are installed at the root of the input and output sides of the inverter, which can effectively suppress the RF interference of the power line.</p> <p>(3) The motor cable should be placed in the barrier with larger thickness, such as in the pipe with thickness (more than 2mm) or embedded in the cement tank. The power line is sheathed in the metal pipe and grounded with the shielded wire (the motor cable adopts 4-core cable, one of which is grounded on the inverter side and the other side is connected to the motor shell).</p>
<p>①⑦⑧</p>	<p>Avoid parallel wiring or binding of strong and weak current wires. It should be far away from the installation equipment of frequency converter as far as possible, and its wiring should be far away from the input and output lines of frequency converter. Shielded wire is used for signal line and power line. For the equipment with strong electric field or magnetic field, pay attention to the relative installation position with frequency converter, and keep the distance and orthogonality.</p>

### 5-1-2. Field wiring and grounding

1. The cable (U, V, W terminal outgoing line) from the frequency converter to the motor should avoid parallel wiring with the power line (R, S, T or L, N terminal input line) as far as possible. Keep a distance of more than 30cm.
2. The three motor wires of inverter output U, V and W terminals shall be placed in metal tube or metal wiring slot.
3. The control signal line shall be shielded cable, and the shielding layer shall be connected with the PE end of the frequency converter, and the single end grounding near the side of the frequency converter.
4. The PE end grounding cable of frequency converter shall not borrow the grounding wire of other equipment, but must be directly connected with the ground.
5. The control signal line shall not be parallel to the strong current cable (R, S, T or L, N and U, V, W) for short distance wiring, and shall not be bundled together. The distance above 20 ~ 60 cm (related to the strong current) shall be maintained. If you want to intersect, you should cross each other vertically, as shown in the figure below.

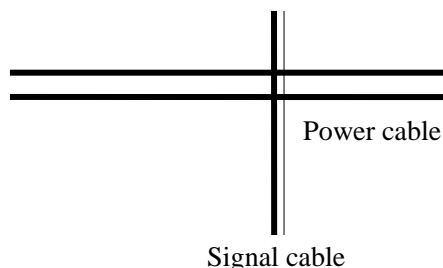

6. Weak current grounding wires such as control signals and sensors must be grounded independently from strong current grounding wires.
7. It is forbidden to connect other devices on the power input terminal (R, S, T or L, N) of frequency converter.

## 6. Model and dimension

### 6-1. VH5 series VFD electrical specification

Voltage level	VFD model	Input power capacity (KVA)	Input current (A)	Output current (A)	Matched motor (kW)
380V/220V 50Hz/60Hz	VH5-40P7	1.5	3.4	2.1	0.75
	VH5-41P5	3.0	5.0	3.8	1.5
	VH5-42P2	4.0	5.8	5.1	2.2
	VH5-43P7	5.9	10.5	9.0	3.7
	VH5-45P5	8.9	14.6	13.0	5.5
	VH5-20P7	1.5	5.6	4.7	0.75
	VH5-21P5	3.0	9.3	7.5	1.5
	VH5-22P2	4.5	12.7	10.0	2.2

### 6-2. VH5 series VFD dimension

- VH5-20P7-B/VH5-21P5-B/VH5-22P2-B  
VH5-40P7-B/VH5-41P5-B/VH5-42P2-B/VH5-43P7

Unit: mm

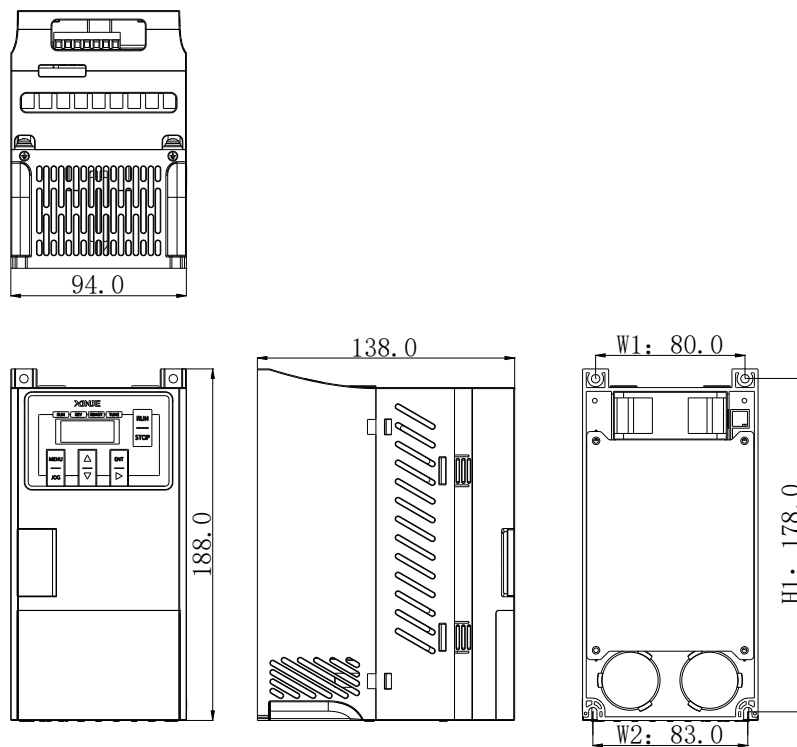

Note: the installation screw is M4.

● VH5-45P5-B

Unit: mm

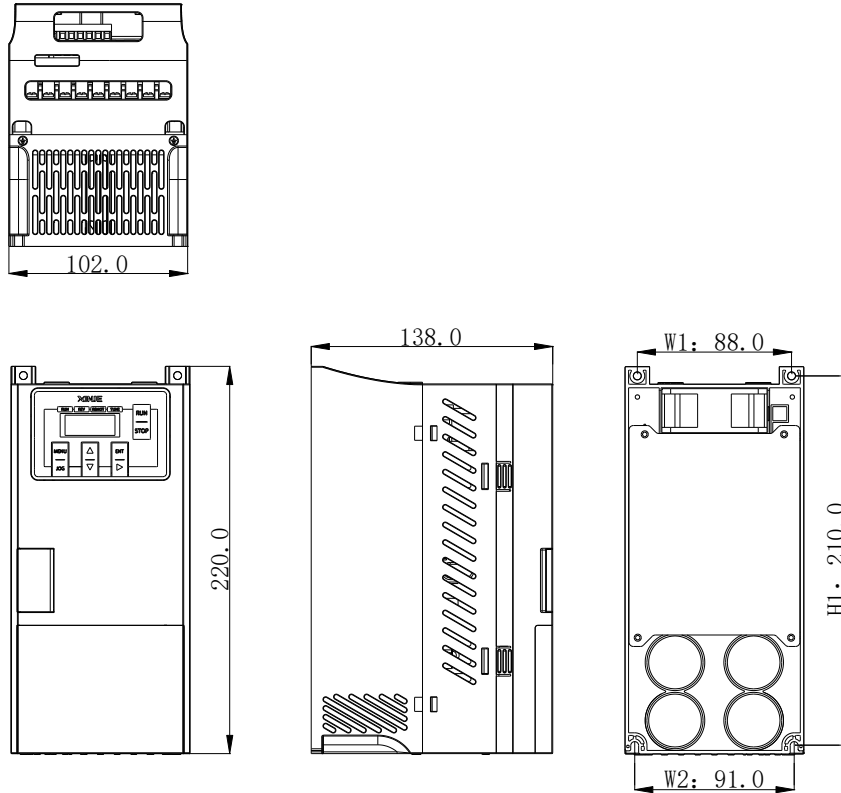

Note: the installation screw is M4.

## 6-3. Accessories selection guide

### 6-3-1. Accessories functions

Name	Functions
Cable	A device for transmitting electrical signals
Circuit breaker	To prevent electric shock and the short circuit to ground which may cause leakage current fire (please select leakage circuit breaker for inverter device and with function of suppressing high harmonic. Rated sensitive current of circuit breaker shall be more than 30mA for one frequency converter.)
AC contactor	In order to effectively cut off the input power of the inverter in case of system failure, an electromagnetic contactor is installed on the input side to control the on-off of the main circuit power supply, so as to ensure safety.
input reactor	It is suitable for improving the power factor of the input side of the inverter and restraining the high-order harmonic current.
DC reactor	
Input filter	To suppress the electromagnetic interference of the inverter transmitted to the public power grid through the input power line, please install it as close to the input terminal side of the inverter as possible.
Fuse	It mainly plays the role of overload protection. When the input current of the frequency converter rises to a certain height and heat, the fuse itself will fuse to cut off the current, which can protect the safe operation of the frequency converter.

Braking resistor	The regenerative energy of motor is consumed by resistor or resistor unit to shorten deceleration time and avoid over-voltage alarm of frequency converter.
Output filter	Suppress the interference generated from the output side wiring of the inverter. Please install it close to the output terminal of frequency converter.
output choke	It is used to extend the effective transmission distance of the frequency converter and effectively suppress the instantaneous high voltage generated when the IGBT module of the frequency converter is switched.

## 6-3-2. Cable selection

### Power cable

- ◆ The size of input power cable and motor cable shall comply with local regulations;
- ◆ The input power cable and motor cable must be able to withstand the corresponding load current;
- ◆ The maximum rated temperature margin of motor cable under continuous working condition should not be lower than 70°C;
- ◆ The conductivity of PE grounding conductor is the same as that of phase conductor;
- ◆ For EMC requirements, please refer to the chapter "EMC";
- ◆ In order to meet the EMC requirements of CE, symmetrical shielded motor cable must be used;
- ◆ Four core cable can be used for input cable, but shielded symmetrical cable is recommended. Compared with four core cable, using symmetrical shielded cable can reduce the loss of motor cable and electromagnetic radiation.

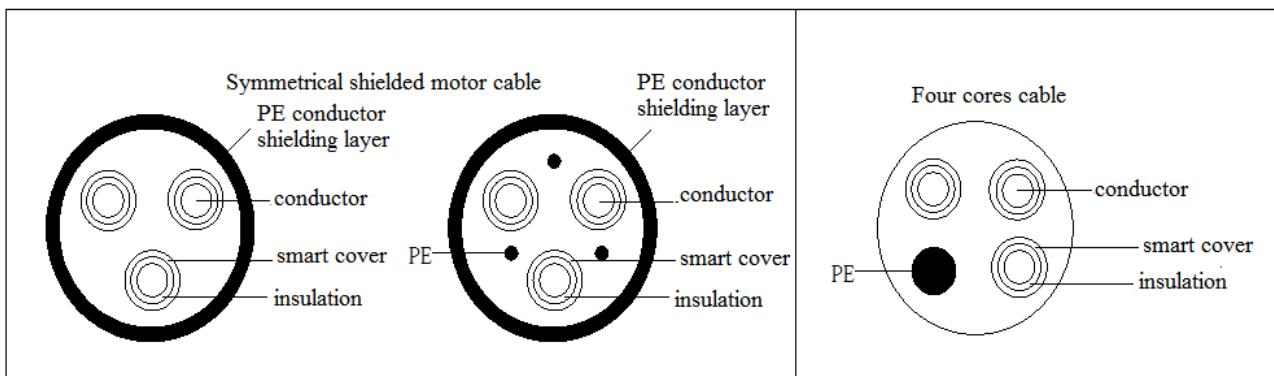

Note: if the conductivity of the shielding layer of the motor cable cannot meet the requirements, a separate PE conductor must be used.

In order to protect the conductor, when the shielding wire and the phase conductor are made of the same material, the cross-sectional area of the shielding wire must be the same as that of the phase conductor, so as to reduce the grounding resistance and improve the impedance continuity.

In order to effectively suppress the emission and conduction of radio frequency interference, the conductivity of the shielding wire must be at least 1/10 of that of the phase conductor. For copper or aluminum shielding, this requirement is very easy to meet. The minimum requirements of inverter motor cable are shown in the figure below. The cable contains a spiral copper strip. The tighter the shielding layer is, the better, because the tighter it is, the more effectively it can suppress the electromagnetic interference radiation.

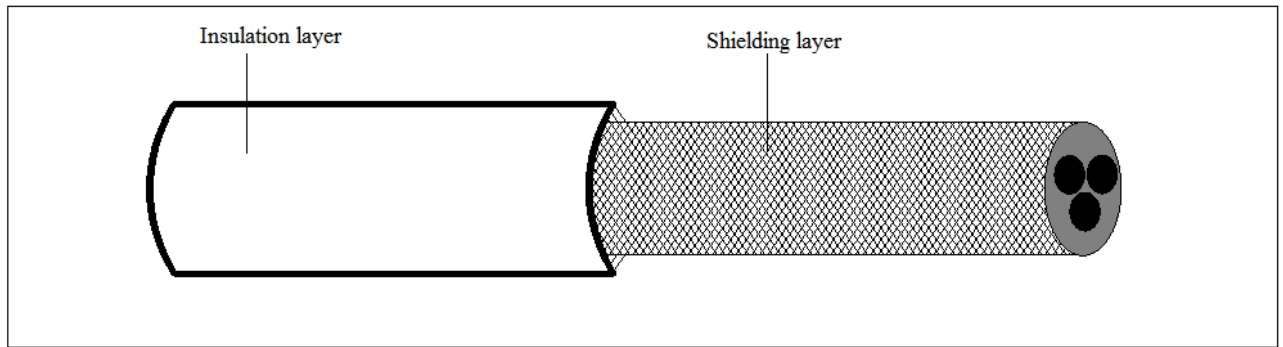

### Control cable

All analog control cables and cables used for frequency input must use shielded cables. The analog signal cable uses twisted pair shielded cable. Each signal uses a separate pair of shielded twisted pairs. Do not use the same ground wire for different analog signals.

For low-voltage digital signal, it is better to choose double layer shielded cable, but single shielded or unshielded twisted pair can also be used, but for frequency signal, shielded cable must be used.

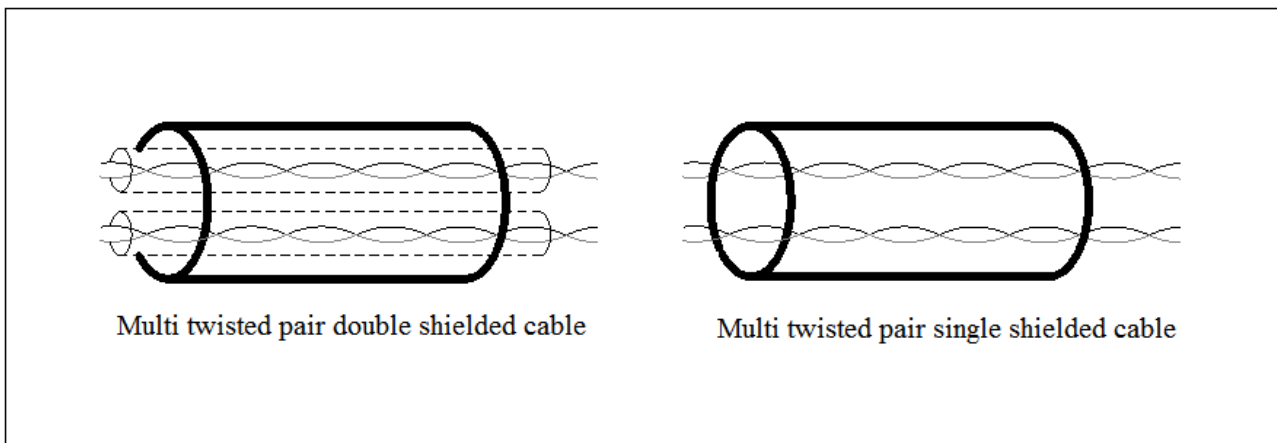

Relay cables need to be shielded with metal braid.

The keyboard needs to use network cable. For the electromagnetic environment, it is recommended to use shielded network wire.

Note:

- (1) Analog and digital signals are routed separately using different cables.
- (2) Before connecting the input power cable of the inverter, check the insulation of the input power cable according to the local regulations.

### Cable wiring

The routing of motor cable must be far away from the routing of other cables. The motor cables of several inverters can be run side by side. It is suggested that the motor cable, input power cable and control cable should be distributed in different trunking. The reason to avoid the side-by-side routing of other cables and motor cables is that the  $du/dt$  output from the inverter will increase the electromagnetic interference to other cables.

If the control cable and the power cable must be crossed, the angle between the control cable and the power cable must be 90 degrees.

The cable trunking must be well connected and well grounded. Aluminum trunking can make local equipotential.

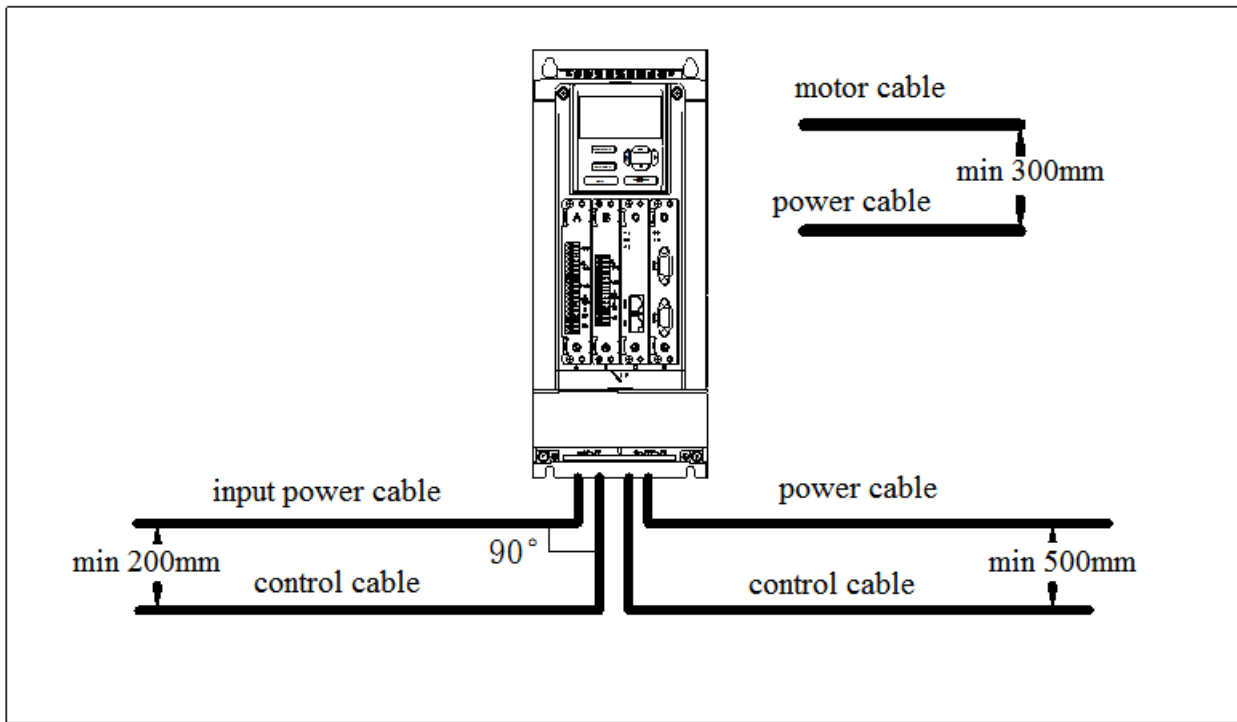

### Insulation inspection

Before operation, please check the insulation of motor and motor cable

- (1) Make sure that the motor cable is connected to the motor, and then remove the motor from the output terminal UVW of the inverter.
- (2) Use a 500VDC megger to measure the insulation resistance between each phase conductor and the protective grounding conductor. For the insulation resistance of the motor, please refer to the motor manufacturer's instructions.
- (3) If the inside of the motor is wet, the insulation resistance will decrease. If moisture is suspected, dry the motor and measure again.

### 6-3-3. Selection guidance of circuit breaker, contactor and fuse

- In order to prevent the overload from damaging the inverter, it is necessary to add a fuse at the incoming end.
- A manually operated power short circuit device (MCCB) needs to be installed between AC power supply and frequency converter. The circuit breaker equipment must be able to be locked in the cut off position to facilitate installation and maintenance. The capacity of the circuit breaker is generally 1.5-2 times of the rated current of the inverter.
- In order to effectively cut off the input power of frequency converter in case of system failure, AC contactor can be installed on the input side to control the on-off of main circuit power supply, so as to ensure safety.

VFD model	Breaker (A)	Rated current of contactor (A)	Fuse (A)
VH5-20P7-B	16	12	2.5
VH5-21P5-B	25	18	4.0
VH5-22P2-B	32	25	4.0
VH5-40P7-B	6	9	6.0
VH5-41P5-B	10	9	10

VH5-42P2-B	10	9	10
VH5-43P7-B	16	12	16
VH5-45P5-B	20	18	20

Note: the parameters of the options in the table are ideal values, which can be adjusted according to the actual situation, but try not to be lower than the parameters in the table.

#### 6-3-4. Reactor selection guide

- In order to prevent the instantaneous large current from flowing into the input power circuit and damaging the rectifier components when the power grid is under high voltage input, AC reactor should be connected to the input side, which can also improve the power factor of the input side.
- When the distance between the inverter and the motor is more than 50 meters, the leakage current is large due to the parasitic capacitance effect of the long cable to the ground, and the inverter is prone to over-current protection. At the same time, in order to avoid the insulation damage of the motor, the output reactor must be added for compensation. When a frequency converter is equipped with multiple motors, the sum of the cable length of each motor is considered as the total length of the motor cable. When the total length is greater than 50m, the output reactor must be added at the output side of the frequency converter.

VFD model	Input reactor	Output reactor
VH5-40P7-B	ACLSG-5A/4.4V	OCLSG-5A/2.2V
VH5-41P5-B	ACLSG-6A/4.4V	OCLSG-6A/2.2V
VH5-42P2-B	ACLSG-6A/4.4V	OCLSG-6/2.2V
VH5-43P7-B	ACLSG-10A/4.4V	OCLSG-10A/2.2V
VH5-45P5-B	ACLSG-15A/4.4V	OCLSG-15A/2.2V

Note: the above options are of Zhengtai brand; users can purchase them according to the model.

#### 6-3-5. Brake resistor selection

When the inverter is slow down with large inertia load or needs to slow down rapidly, the motor will be in power generation state. The load energy will be transmitted to the DC link of the converter through the inverter bridge, which causes the voltage rise of the converter bus. When the value exceeds a certain value, the frequency converter will report an over-voltage alarm. In order to prevent this phenomenon, the brake components must be configured.



1. The design, installation, commissioning and operation of the equipment must be carried out by trained and qualified professionals.
2. In the process of work, all the provisions in the "warning" must be observed, otherwise serious personal injury or heavy property loss may be caused.
3. Non professional construction personnel are not allowed to conduct wiring, otherwise the circuit of frequency converter or brake options will be damaged.
4. Before connecting the brake resistor to the inverter, please read the instruction manual of the brake resistor / brake unit carefully.
5. Do not connect the brake resistor to terminals other than PB and P+, and do not connect the brake unit to terminals other than P+ and P-. Otherwise, the brake circuit and frequency converter may be damaged and fire may be caused.





As shown in the wiring diagram, please connect the inverter with the braking resistance. If the wiring is wrong, the inverter or other equipment may be damaged.

### Brake resistor selection

When braking, the regenerative energy of the motor is almost all consumed on the braking resistance. According to the formula:

$$U \times U / R = P_b$$

U --- Braking voltage of system stable braking (different system U values are different, the default braking voltage of VH6 series inverter is 700V, which can be adjusted through P7-59),

P<sub>b</sub> --- Braking power.

### Brake resistor power selection

Theoretically, the power of the braking resistor is the same as that of the braking power, but considering that the derating is A. According to the formula:

$$A \times P_r = P_b \times D$$

A --- Generally, the value is about 50%,

P<sub>r</sub> --- Resistor power,

D --- Braking frequency, that is, the proportion of regeneration process in the whole working process

Note: value A is the derating coefficient of the braking resistance. A lower value A can ensure that the braking resistance will not overheat. Users can appropriately increase value A when the braking is good, but it is better not to exceed 50%, otherwise there will be the risk of fire caused by overheated resistance.

### Typical braking frequency value

Common applications	Elevator	Unwinding and winding	Centrifuge	Accidental braking load	General occasions
Braking frequency value	20% ~30%	20 ~30%	50%~60%	5%	10%

### Brake resistor models

VFD model	Recommended brake resistor specifications			
	Specification	Brake resistor (Ω)	Brake resistor power (W)	Brake resistor quantity
VH5-40P7-B	Built-in	≥300	≥150	1
VH5-41P5-B	Built-in	≥220	≥150	1
VH5-42P2-B	Built-in	≥200	≥250	1
VH5-43P7-B	Built-in	≥130	≥300	1
VH5-45P5-B	Built-in	≥90	≥500	1
VH5-20P7-B	Built-in	≥150	≥200	1
VH5-21P5-B	Built-in	≥100	≥320	1
VH5-22P2-B	Built-in	≥60	≥530	1

#### Note:

- (1) The values in the table are guidance data. Users can choose different resistance values and power according to the actual situation (but the resistance value must not be less than the recommended value)

in the table, and the power can be larger). The selection of braking resistance needs to be determined according to the power generated by the motor in the practical application system, which is related to the system inertia, deceleration time, energy of potential energy load, etc, Customers need to choose according to the actual situation. The greater the inertia of the system, the shorter the deceleration time and the more frequent the braking, the greater the power and the smaller the resistance value of the braking resistor.

- (2) The brake resistance cable shall be shielded cable.
- (3) All resistors must be installed in a well ventilated place.
- (4) It is suggested that the material of brake resistor accessories should be flame retardant, and the surface temperature of the resistor is very high. Even the temperature of the air flowing out of the resistance can be as high as several hundred degrees, so the material must be prevented from contacting with the resistance.
- (5) The brake resistor must be connected to the PB and P + terminals, and the brake unit must be connected to the P+ and P- terminals. As shown in the figure below:

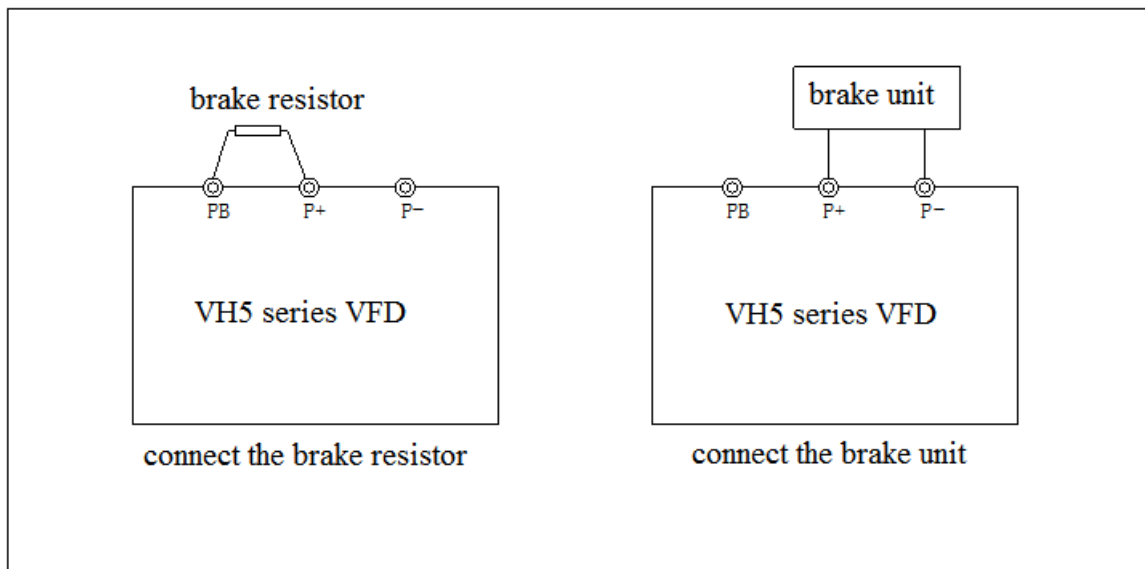

# 7. Fault and solution

## 7-1. Fault alarm and solution

When the inverter is abnormal, the LED tube will display the function code and its content of the corresponding fault, the fault relay will act, and the inverter will stop output. In case of fault, if the motor is rotating, it will stop freely until it stops rotating. The possible fault types of frequency converter are shown in the table. When the frequency converter fails, the user should first check according to the table, and record the failure phenomenon in detail. If you need technical service, please contact our after-sales service and technical support department or our agents.

Code	Name	Reason	Solution
Err01	Acceleration over current	<ol style="list-style-type: none"> <li>1. There is grounding or short circuit in the output circuit of frequency converter</li> <li>2. The control mode is vector control without parameter tuning</li> <li>3. The acceleration time is too short</li> <li>4. Improper manual torque lifting or VF curve</li> <li>5. The voltage is low</li> <li>6. Start the rotating motor</li> <li>7. Sudden loading during acceleration</li> <li>8. The selection of frequency converter is too small</li> </ol>	<ol style="list-style-type: none"> <li>1. Remove peripheral faults</li> <li>2. Tuning of motor parameters</li> <li>3. Increase acceleration time</li> <li>4. Adjust the manual lifting torque or VF curve</li> <li>5. Adjust the voltage to the normal range</li> <li>6. Select speed tracking start or wait until the motor stops</li> <li>7. Cancel sudden loading</li> <li>8. Choose the frequency converter with higher power level</li> </ol>
Err02	Deceleration over current	<ol style="list-style-type: none"> <li>1. There is grounding or short circuit in the output circuit of frequency converter</li> <li>2. The control mode is vector control without parameter tuning</li> <li>3. The deceleration time is too short</li> <li>4. The voltage is low</li> <li>5. Sudden loading during deceleration</li> <li>6. There is no additional brake unit and brake resistor</li> </ol>	<ol style="list-style-type: none"> <li>1. Remove peripheral faults</li> <li>2. Tuning of motor parameters</li> <li>3. Increase deceleration time</li> <li>4. Adjust the voltage to the normal range</li> <li>5. Cancel sudden loading</li> <li>6. Add brake unit and resistor</li> </ol>
Err03	Constant speed over current	<ol style="list-style-type: none"> <li>1. There is grounding or short circuit in the output circuit of frequency converter</li> <li>2. The control mode is vector control without parameter tuning</li> <li>3. The voltage is low</li> <li>4. Is there sudden load in operation</li> <li>5. The selection of frequency converter is too small</li> </ol>	<ol style="list-style-type: none"> <li>1. Remove peripheral faults</li> <li>2. Tuning of motor parameters</li> <li>3. Adjust the voltage to the normal range</li> <li>4. Cancel sudden loading</li> <li>5. Choose the frequency converter with higher power level</li> </ol>
Err04	Acceleration overvoltage	<ol style="list-style-type: none"> <li>1. High input voltage</li> <li>2. There is external force to drive the motor during acceleration</li> <li>3. Acceleration time too short</li> <li>4. There is no additional brake unit and brake resistor</li> </ol>	<ol style="list-style-type: none"> <li>1. Adjust the voltage to the normal range</li> <li>2. Cancel additional force or add brake resistor</li> <li>3. Increase acceleration time</li> <li>4. Add brake unit and resistor</li> </ol>
Err05	Deceleration overvoltage	<ol style="list-style-type: none"> <li>1. High input voltage</li> <li>2. There is external force to drive the motor during deceleration</li> </ol>	<ol style="list-style-type: none"> <li>1. Adjust the voltage to the normal range</li> <li>2. Cancel additional force or add brake</li> </ol>

Code	Name	Reason	Solution
		3. The deceleration time is too short 4. There is no additional brake unit and brake resistor	resistor 3. Increase deceleration time 4. Add brake unit and resistor
Err06	Constant speed over voltage	1. High input voltage 2. In the process of operation, there is external force to drive the motor	1. Adjust the voltage to the normal range 2. Cancel additional force or add brake resistor
Err07	Buffer resistance overload fault	1. Unstable supply voltage 2. The main control board is abnormal	1. Adjust the voltage to the normal range 2. Contact us
Err08	Under voltage	1. Instantaneous power failure 2. The input voltage of frequency converter is not in the range of specification requirements 3. Abnormal bus voltage 4. Abnormal rectifier bridge and buffer resistance 5. Abnormal drive board 6. Abnormal control board	1. Reset fault 2. Adjust the voltage to the normal range 3. Contact us
Err09	VFD overload	1. Whether the load is too large or the motor stalls 2. The selection of frequency converter is too small	1. Reduce the load and check the motor and mechanical condition 2. Choose the frequency converter with higher power level
Err10	Motor overload	1. Is the setting of motor protection parameters appropriate 2. Whether the load is too large or the motor stalls 3. The selection of frequency converter is too small	1. Set this parameter correctly 2. Reduce the load and check the motor and mechanical condition 3. Choose the frequency converter with higher power level
Err11	Input lack phase	1. Abnormal three-phase input power supply 2. Abnormal drive board 3. Abnormal lightning protection board 4. The main control board is abnormal	1. Check and eliminate problems in peripheral circuit 2. Contact us
Err12	Output lack phase	1. The lead from inverter to motor is abnormal 2. The three-phase output of inverter is unbalanced when the motor is running 3. Abnormal drive board 4. Module is abnormal	1. Remove peripheral faults 2. Check whether the three-phase winding of the motor is normal and remove the fault 3. Contact us
Err13	Overheated radiator / module	1. The ambient temperature is too high 2. Air duct blocked 3. The fan is damaged 4. Module thermistor damaged 5. Inverter module damaged	1. Reduce the ambient temperature 2. Clean the air duct 3. Replace the fan 4. Replace the thermistor 5. Replace inverter module
Err14	Contact fault	1. Abnormal drive board and power supply 2. The contactor is abnormal	1. Replace the drive board or power board 2. Replace the contactor
Err15	Current detection fault	1. Check the Hall device 2. Abnormal drive board	1. Replace Hall element 2. Replace the drive plate
Err16	Motor tuning	1. The motor parameters are not set	1. Set the motor parameters correctly

Code	Name	Reason	Solution
	fault	according to the nameplate 2. Parameter tuning process timeout	according to the name plate 2. Check the lead from inverter to motor
Err17	Code disk failure	1. Encoder model mismatch 2. Encoder connection error 3. Encoder damaged 4. Abnormal PG card	1. Set encoder type correctly 2. Remove circuit fault 3. Change encoder 4. Replace PG card
Err18	Short circuit fault of motor to ground	Motor short circuit to ground	Replace motor or cable
Err19	Load drop	VFD operation current is lower than P7-61	Confirm whether the load is separated or whether the P7-61 and P7-62 parameter settings conform to the actual operating conditions
Err20	Wave by wave current limiting fault	1. Whether the load is too large or the motor stalls 2. The selection of frequency converter is too small	1. Reduce the load and check the motor and mechanical condition 2. Choose the frequency converter with higher power level
Err21	Pole position detection failed	The deviation between the motor parameters and the actual value is too large	Re-determine the motor parameters, focusing on whether the motor rated current is too small
Err23	Brake resistance short circuit	Output current too high	1. Increase acceleration and deceleration time 2. Reduce the load
Err26	SVC stall fault	1. Excessive load 2. Torque limit too small (P6-11)	1. Reduce the load 2. Increase torque limit
Err43	External fault	1. Input the signal of external fault through multi-function terminal X 2. Input external fault signal through virtual Y function	Reset and run again
Err44	Communication (timeout) fault	1. The upper computer is not working properly 2. The communication cable is abnormal 3. Incorrect setting of communication parameter group PC	1. Check the upper computer wiring 2. Check the communication cable 3. Setting communication parameters correctly
Err45	EEPROM read write error	EEPROM chip damaged	Replace the main circuit board
Err46	Operation time arrival	The accumulated running time reaches the set value	Use the parameter initialization function to clear the record information
Err47	Power on time arrival	The accumulated power on time reaches the set value	Use the parameter initialization function to clear the record information
Err48	User defined fault 1	1. Input user-defined fault 1 signal through multi-function terminal X 2. Input user defined fault 1 signal through virtual IO function	Reset and run again
Err49	User defined fault 2	1. Input user-defined fault 2 signal through multi-function terminal X 2. Input user defined fault 2 signal through virtual IO function	Reset and run again
Err50	PID feedback	PID feedback is less than P7-27 setting	Check PID feedback signal or set

Code	Name	Reason	Solution
	lost in operation	value	P7-27 to an appropriate value
Err51	Switch motor in operation	In the process of inverter operation, change the current motor selection through the terminal	Switch the motor after the frequency converter stops
Err52	Speed offset too large	1. Encoder parameter setting incorrect 2. Motor blocked 3. Incorrect UVW wiring	1. Setting encoder parameters correctly 2. Check whether the machine is abnormal 3. Check whether the wiring between frequency converter and motor is abnormal
Err53	Motor overspeed fault	1. Incorrect setting of encoding parameters 2. The motor is not tuned 3. Unreasonable setting of motor over speed detection parameters P7-63 and P7-64	1. Setting encoder parameters correctly 2. Tuning correctly 3. Set reasonable parameters according to the actual situation
Err54	Motor overheat fault	1. Loose wiring of temperature sensor 2. Motor temperature too high	1. Check the wiring of temperature sensor 2. Reduce the carrier wave or take other measures to dissipate the motor heat.

## 7-2. Fault record query

This series of frequency converter records the fault codes and operation parameters of the frequency converter for the last three times. Querying these information is helpful to find out the cause of the fault. All fault information is saved in P7 group parameters. Please refer to the keyboard operation method to enter P7 group parameters to check the information.

## 7-3. Fault reset

In case of a failure of the inverter, to resume normal operation, you can select any of the following operations:

- (1) When the fault code is displayed, press stop after confirming that it can be reset.
- (2) Set any terminal of X1-X4 to reset stop input for external fault, and then disconnect from com terminal after closing.
- (3) Cut off the power supply.

Note:

- (1) Before reset, the reason of the fault must be thoroughly identified and eliminated, otherwise, the permanent damage of the frequency converter may be caused.
- (2) If the fault cannot be reset, check the reason, and the continuous reset will damage the inverter.
- (3) When overload and overheating protection acts, it shall be reset 5 minutes later.

## 7-4. VFD common fault analysis

### 7-4-1. Motor not rotate

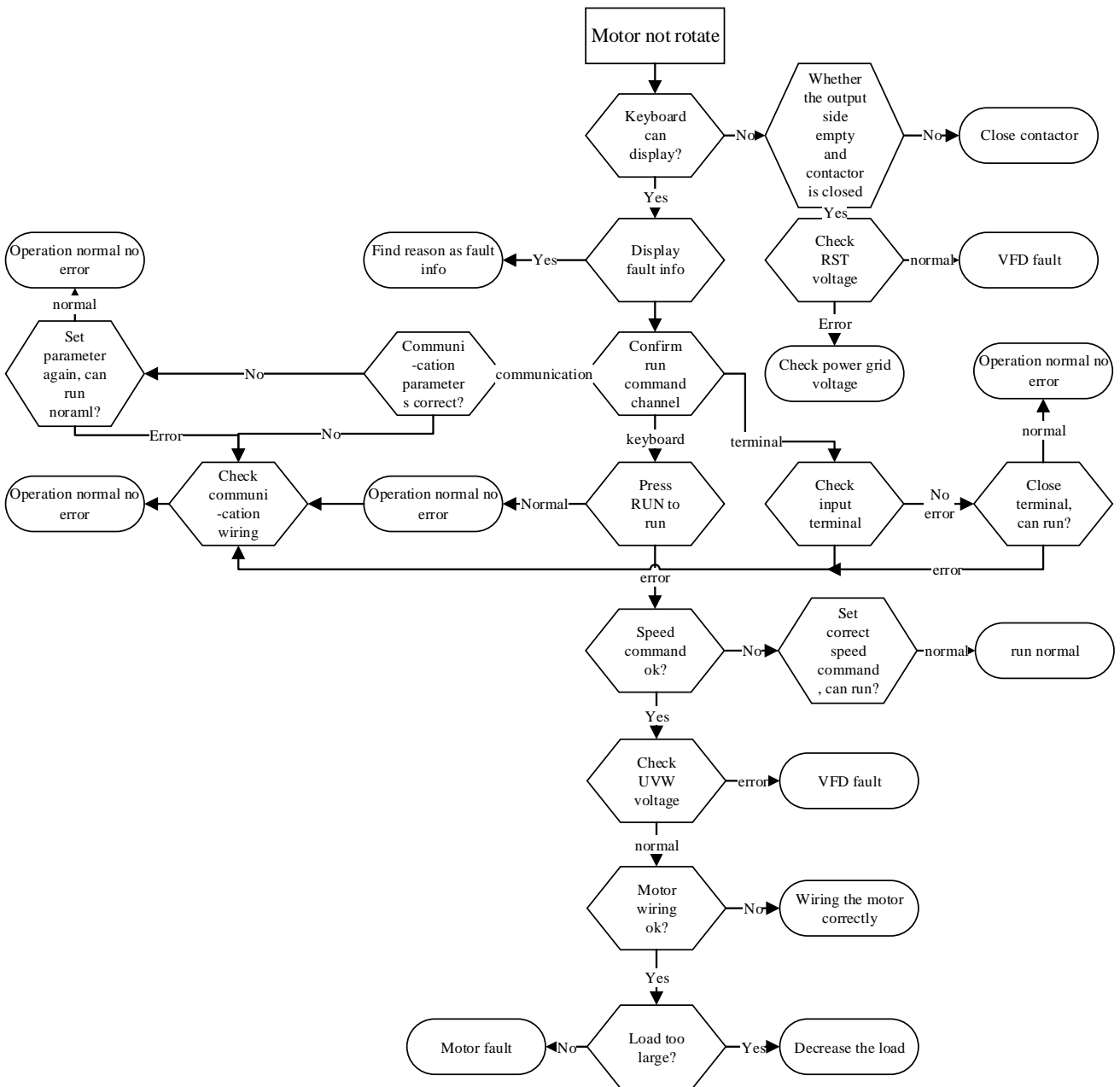

### 7-4-2. Motor vibration

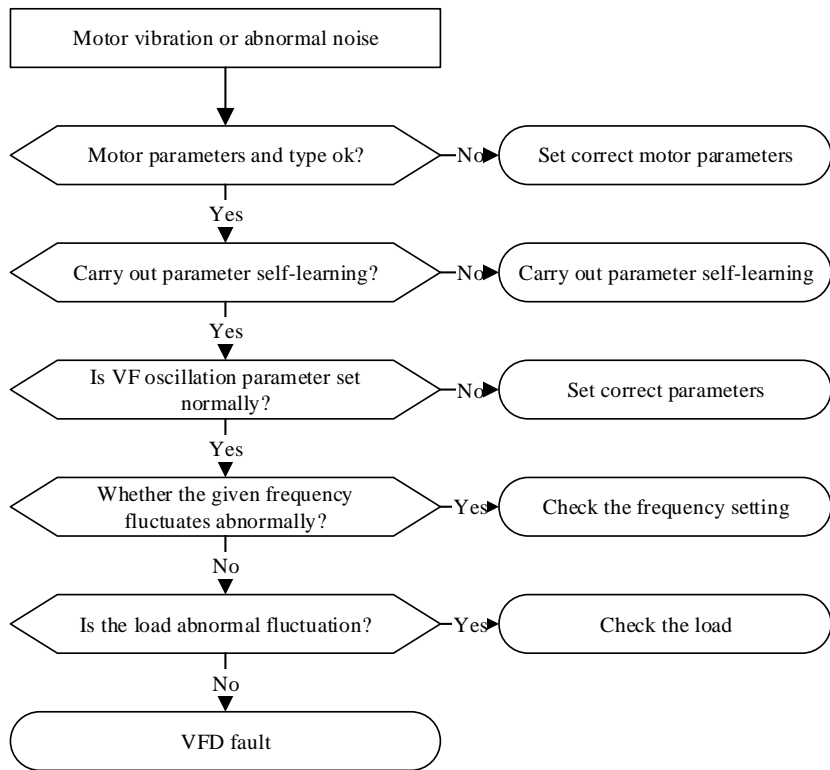

### 7-4-3. Over voltage

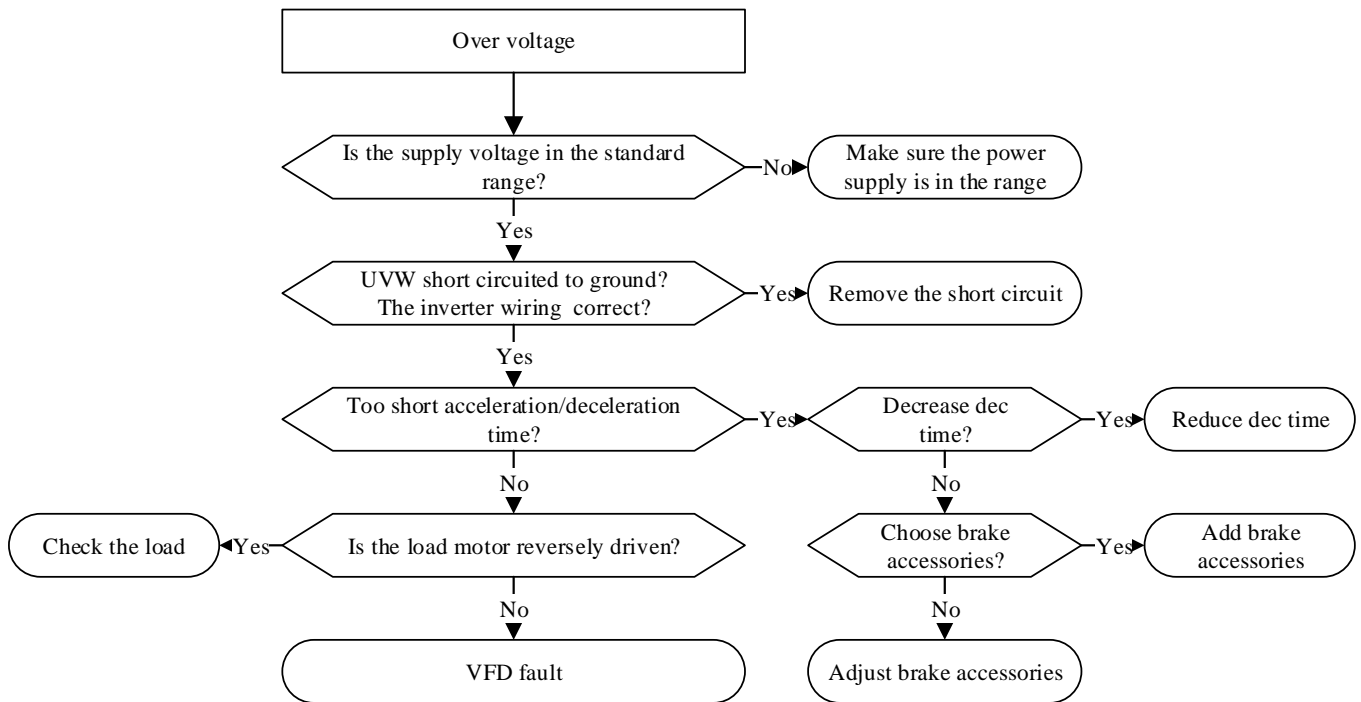



#### 7-4-4. Motor overheat

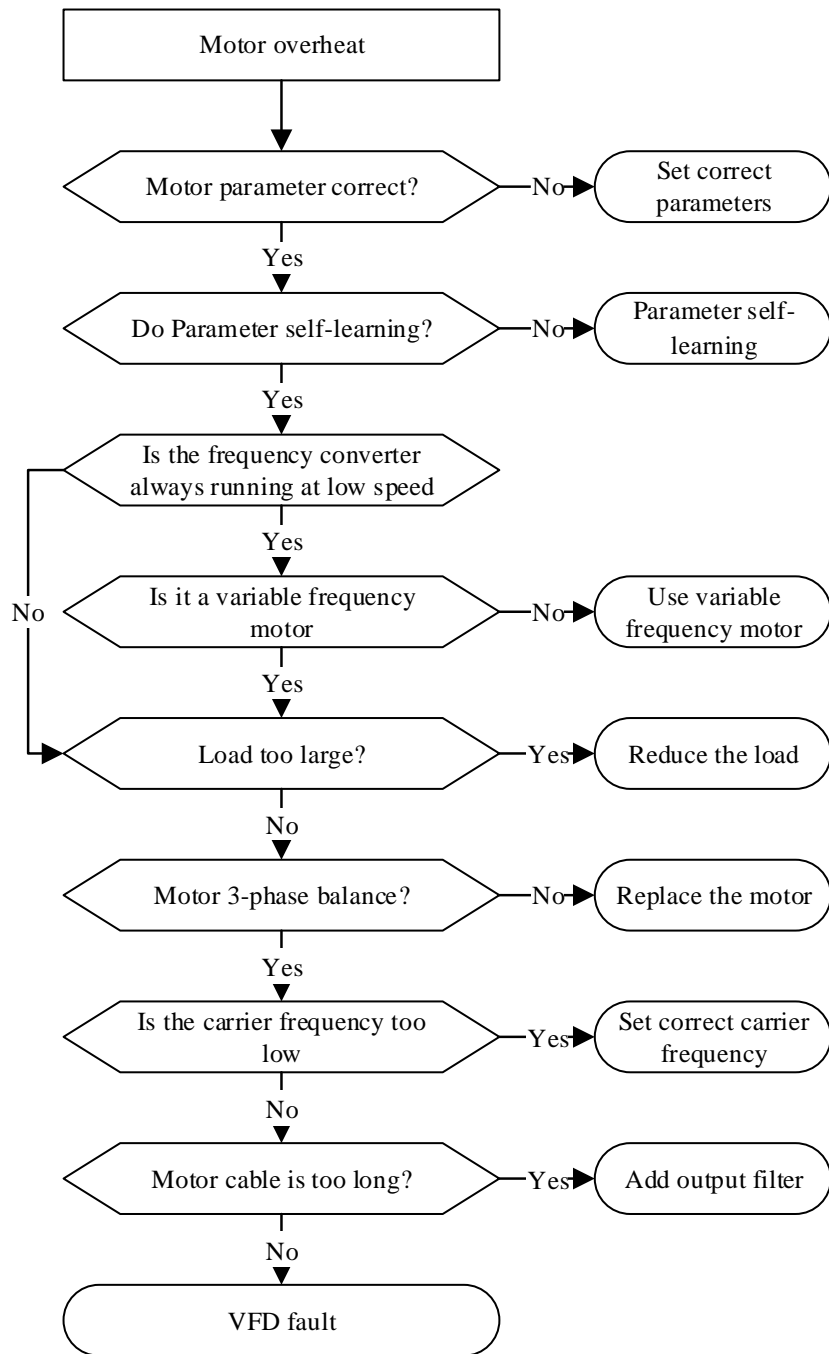

### 7-4-5. Over current

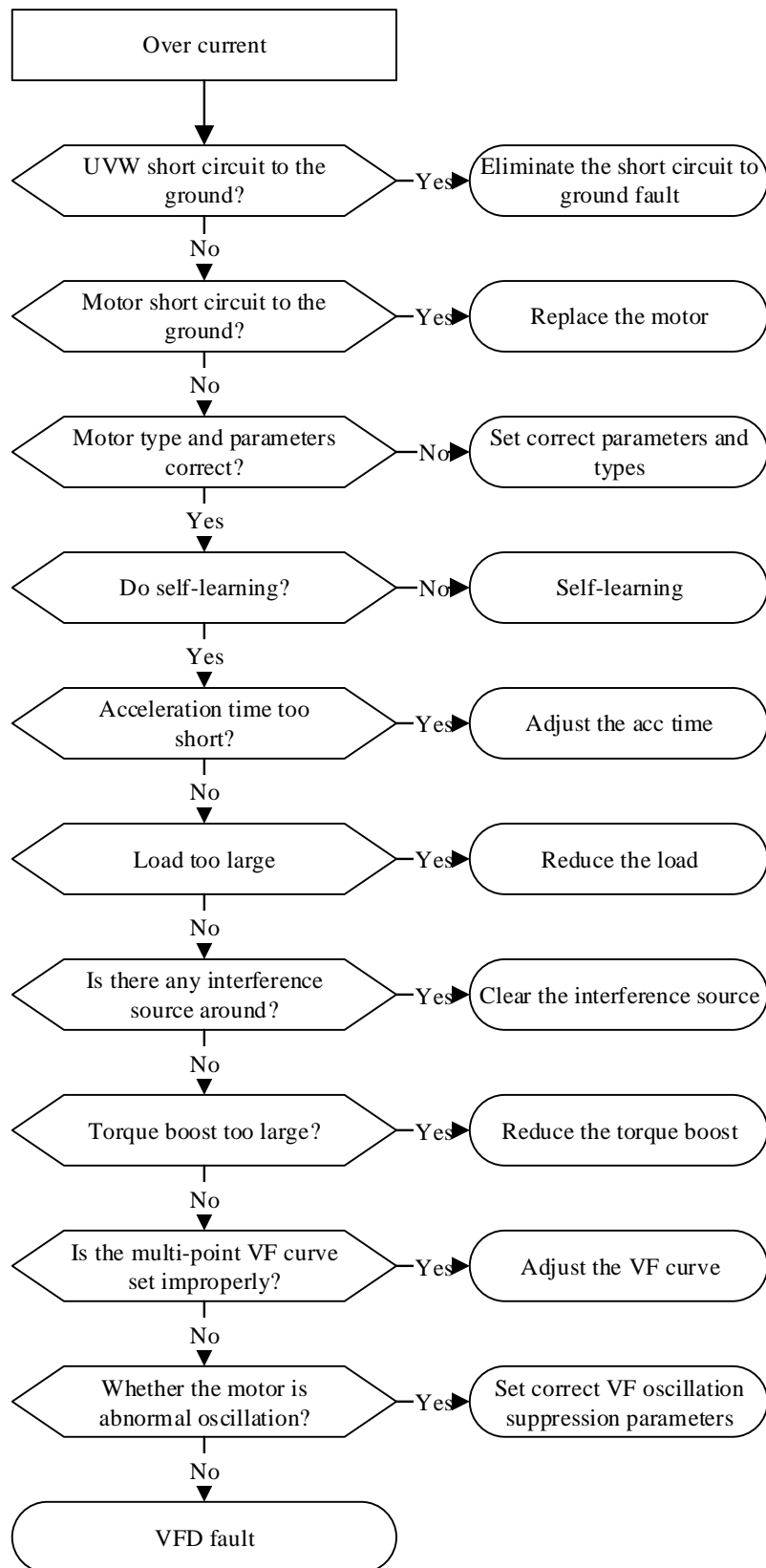

## 7-4-6. VFD overheat

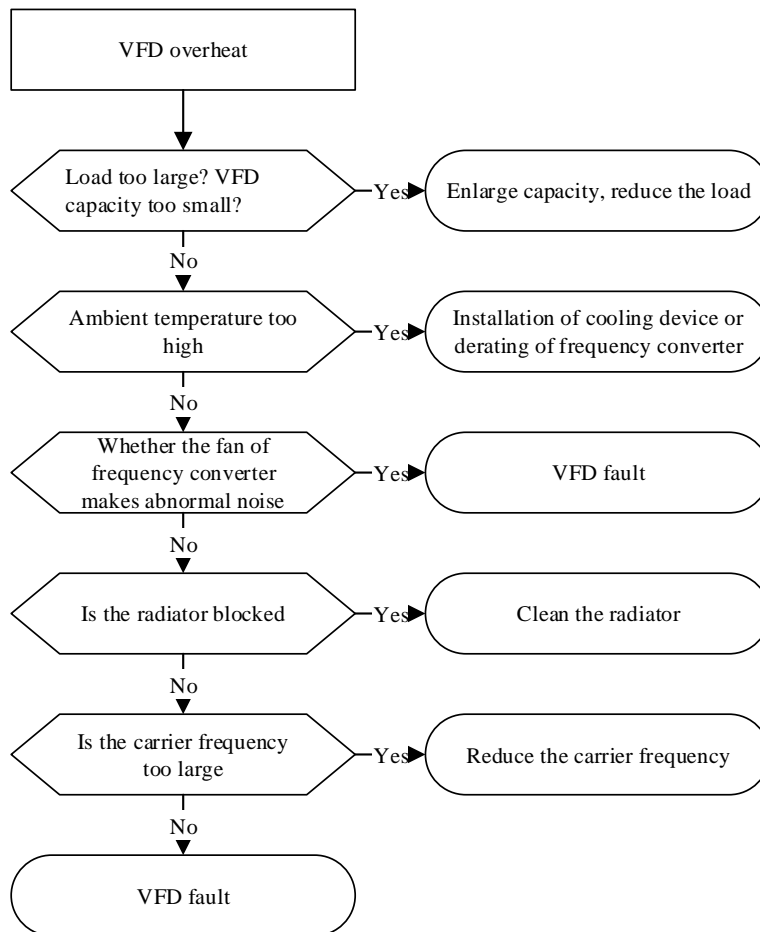

### 7-4-7. The motor stalls during acceleration and deceleration

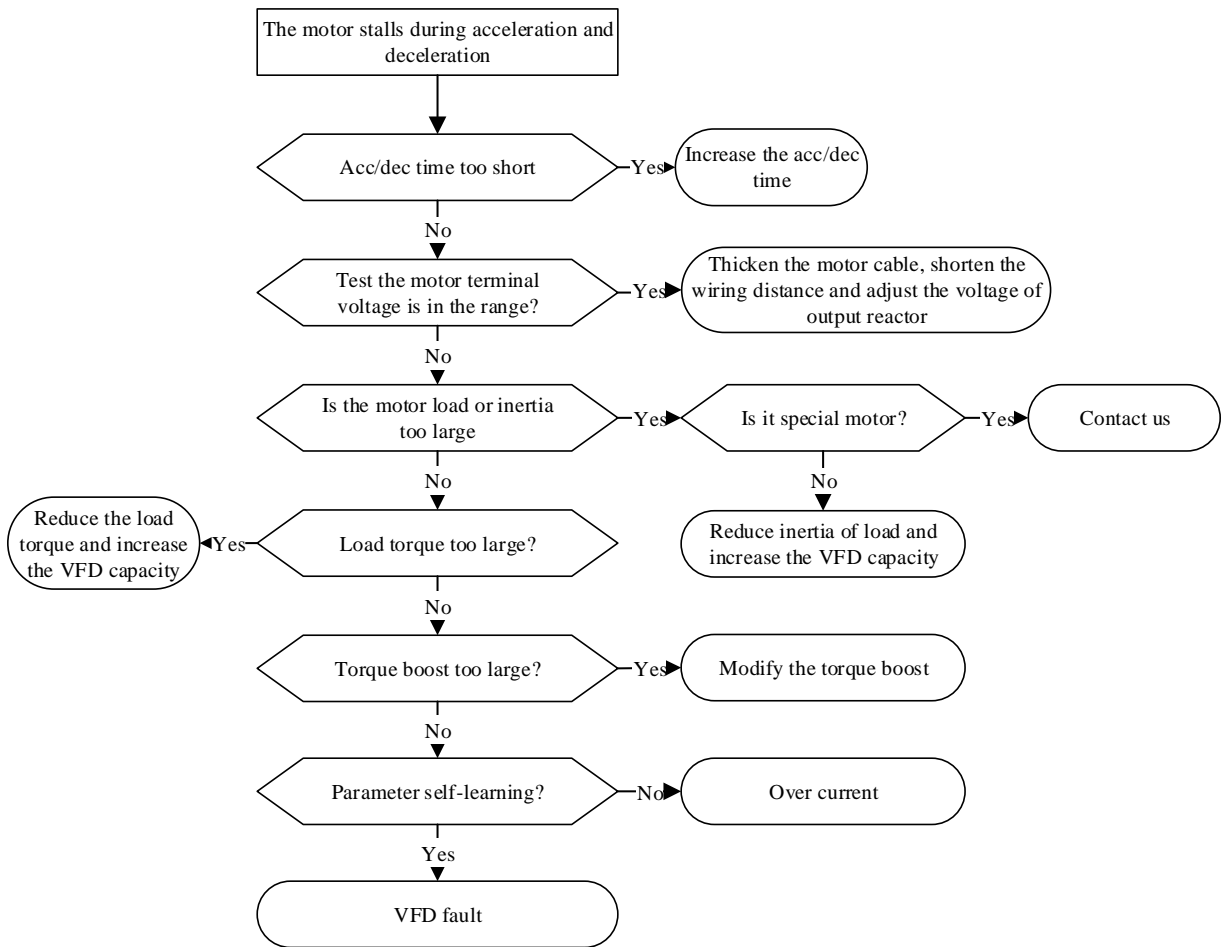

### 7-4-8. Under voltage

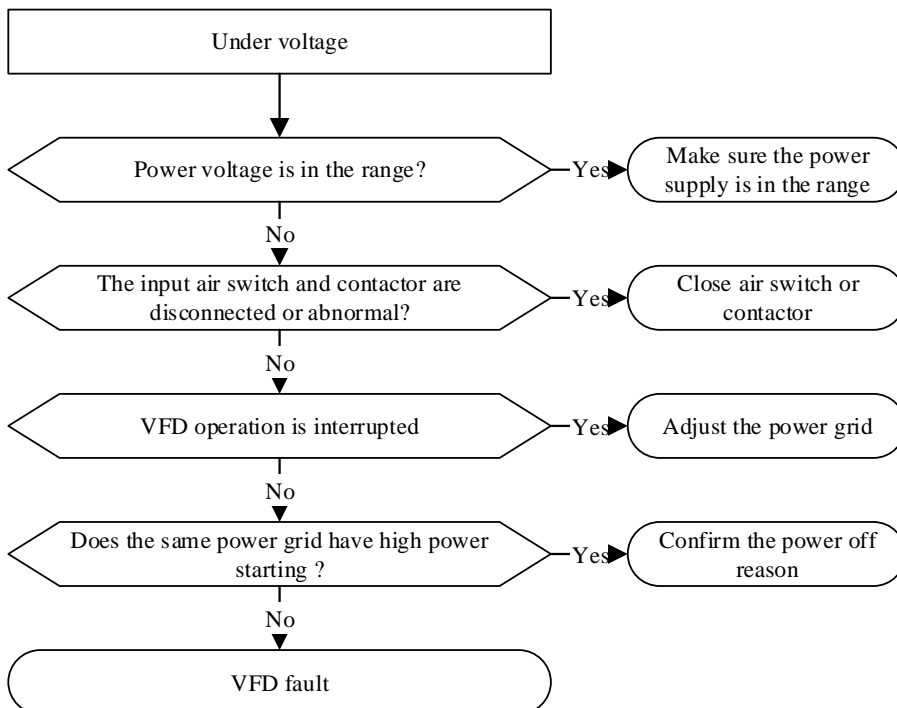

---

## 8. Maintenance

The change of the operating environment of the inverter, such as the influence of temperature, humidity, smoke, etc., and aging of the internal components of the converter, may lead to various faults of the inverter. Therefore, the inverter must be checked daily during storage and use, and regular maintenance should be carried out.

### 8-1. Routine maintenance

When the frequency converter is turned on normally, please confirm the following items:

- (1) Whether the motor has abnormal sound and vibration.
- (2) Whether the frequency converter and motor have abnormal heating.
- (3) Whether the ambient temperature is too high.
- (4) Whether the load ammeter is the same as usual.
- (5) Check whether the cooling fan of frequency converter operates normally.

### 8-2. Regular maintenance

When the frequency converter is regularly maintained and inspected, it is necessary to cut off the power supply, and the inspection can only be carried out after the monitor is not displayed and the power indicator of the main circuit is off. The inspection contents are shown in the table below.

Item	Contents	Solution
Screw of main circuit terminal and control circuit terminal	Is the screw loose	Tighten with a screwdriver
Heat sink	Is there any dust	Blow off with 4 ~ 6kgcm <sup>2</sup> dry compressed air
PCB board	Is there any dust	Blow off with 4 ~ 6kgcm <sup>2</sup> dry compressed air
Cooling fan	Whether there is abnormal sound and vibration, and the accumulated operation time is up to 20000 hours	Replace the fan
Power element	Is there any dust	Blow off with 4 ~ 6kgcm <sup>2</sup> dry compressed air
Aluminum electrolytic capacitor	Discoloration, odor and blistering	Replace the Aluminum electrolytic capacitor

In order to make the inverter work normally for a long time, regular maintenance must be carried out according to the service life of the internal electronic components of the inverter. The service life of electronic components of frequency converter is different because of its different environment and conditions. As shown in the table below, the maintenance period of frequency converter is only for users' reference.

Component name	Standard replacement years
Cooling fan	2~3 years
Electrolytic capacitor	4~5 years
PCB board	5~8 years

---

Fuse	10 years
------	----------

The service conditions for the replacement time of the above inverter components are as follows:

- (1) Ambient temperature: annual average 30°C.
- (2) Load factor: below 80%.
- (3) Running time: less than 12 hours per day.

### **8-3. Warranty of frequency converter**

The company will provide warranty service in case of the following conditions:

- (1) The warranty scope only refers to the inverter body;
- (2) In normal use, if the inverter fails or is damaged within 15 months, the company is responsible for the warranty; reasonable maintenance fee will be charged for more than 15 months;
- (3) Within 15 months, a certain maintenance fee shall also be charged in case of the following situations:
  - Failure to follow the operation steps in the instruction manual will cause damage to the frequency converter;
  - Frequency converter damage caused by flood, fire, abnormal voltage, etc;
  - Frequency converter damage caused by wrong connection cable, etc;
  - Damage caused by using frequency converter for abnormal functions;
- (4) The service fee shall be calculated according to the actual cost. If there is a contract, it shall be handled according to the principle of contract priority.

---

# Appendix

## Appendix A. Extension card

VH5 series frequency converter can support fieldbus expansion cards. This chapter describes the installation and use of each expansion card.

VFD model	Extension card	Function	Using model
VH5-CC100	EtherCAT card	Support EtherCAT protocol	VH5 series models
VH5-CN100	CANopen card	Support CANopen protocol	VH5 series models

### Appendix A-1. Extension card functions

#### Appendix A-1-1. VH5-CC100 EtherCAT card

##### (1) Overview

EtherCAT is an open architecture fieldbus system based on Ethernet. It sets a new standard for the real-time performance and topology flexibility of the system. At the same time, it also meets or even reduces the use cost of fieldbus. VH5-CC100 is an extended card specially designed for EtherCAT protocol by Xinje company, which is specially suitable for Xinje frequency converter. Through this card, the Xinje frequency converter can be connected to the international standard EtherCAT network and exist as a slave station.

##### (2) Pin definition

VH5-CC100 card has two Ethernet port, the pin definition is shown as the following:

Terminal no.	Name	Function
1	TX A+	Data send +
2	TX A-	Data send -
3	RX A+	Data receive +
4	Vacant	-
5	Vacant	-
6	RX A-	Data receive -
7	Vacant	-
8	Vacant	-

#### Appendix A-1-2. VH5-CN100 Canopen card

##### (1) Overview

CANopen complies with CANopen application layer protocol of CAN Fieldbus international standard. VH5-CN100 is an extended card specially designed for CANopen protocol by Xinje company, which is specially suitable for Xinje frequency converter. Through this card, Xinje frequency converter can be connected to CANopen network and exist as a slave station.

##### (2) Pin definition

---

VH5-CN100 card has two Ethernet port, the pin definition is shown as the following:

Terminal no.	Name	Function
1	CAN_H	Connect to CAN+
2	CAN_L	Connect to CAN-
3	CGND	Connect to CAN ground
4~10	Vacant	Vacant

## Appendix B. Communication protocol

### Appendix B-1. Communication protocol overview

VH5 series frequency converter provides the general RS485 communication interface in industrial control to users. The communication protocol adopts MODBUS standard communication protocol. The converter can be used as slave and communicate with the upper computer with the same communication interface and the same communication protocol (such as PLC controller and PC) to realize centralized monitoring of the frequency converter. In addition, the user can also use a frequency converter as the master, and connect several frequency converters of our company as slave through RS485, in order to realize the multi-machine linkage of the frequency converter. The remote control keyboard can also be connected through the communication port to realize the remote operation of the frequency converter by users.

The Modbus communication protocol of this converter supports RTU mode. The following is a detailed description of the communication protocol of the inverter.

### Appendix B-2. Communication protocol explanation

#### Appendix B-2-1. Communication protocol mode

The inverter can be used as the master or slave in RS485 network. When used as the master, it can control other frequency converters of our company to realize multi-level linkage. When it is used as slave, PC or PLC can be used as the master to control the inverter. The specific communication mode is as follows:

- (1) The frequency converter is slave, and the master-slave point-to-point communication is adopted. When the master uses the broadcast address to send commands, the slave does not respond.
- (2) As the master, the frequency converter sends commands to the slave using broadcast address, and the slave does not respond.
- (3) Users can set the local address, baud rate and data format of the converter by keyboard or serial communication.
- (4) The slave reports the current fault information in the last reply frame to the master.

#### Appendix B-2-2. Communication port

The communication is RS485 interface, asynchronous serial, half duplex transmission. The default data format is: 1 start bit, 8 data bits and 1 stop bit.

The default baud rate is 19200bps. Please refer to P9 group parameters for communication parameter settings.



## Appendix B-3. Modbus-RTU protocol

### Appendix B-3-1. Character structure

(1-8-2, no parity)

Start bit	0	1	2	3	4	5	6	7	Stop bit	Stop bit
-----------	---	---	---	---	---	---	---	---	----------	----------

(1-8-1, odd parity)

Start bit	0	1	2	3	4	5	6	7	Odd parity	Stop bit
-----------	---	---	---	---	---	---	---	---	------------	----------

(1-8-1, even parity)

Start bit	0	1	2	3	4	5	6	7	Even parity	Stop bit
-----------	---	---	---	---	---	---	---	---	-------------	----------

(1-8-1, no parity)

Start bit	0	1	2	3	4	5	6	7	Stop bit
-----------	---	---	---	---	---	---	---	---	----------

### Appendix B-3-2. Communication data structure

#### RTU mode

START	Keep no input signal at least 10ms
Address	Communication address: 8-bit binary address
Function	Function code: 8-bit binary address
DATA (n-1)	Data content: N*8-bit data, N<=8, max 8 bytes
.....	
DATA 0	
CRC CHK Low	CRC parity
CRC CHK High	16-bit CRC parity code is composed of two 8-bit binary
END	Keep no IO signal at least 10ms

#### Communication address

00H: all frequency converter broadcast

01H: communicate with 01 address inverter.

0FH: communication with 15 address inverter.

10H: communication with 16 address inverter. And so on... , up to 254 (FEH).

#### Function code and data

Function code	Explanation
03H	Read the contents of registers, read multiple registers, but not more than 12 at a time, each time can only read the same group of data
06H	Write data into the register
08H	Loop detection

(1) Function code 03H: read register

For example, read the register address 7000H (operation frequency).

RTU mode

Format of inquiry information		Format of response information	
Address	01H	Address	01H
Function code	03H	Function code	03H
Register address	70H	Byte number	02H
	00H		
Register quantity	00H	Data contents	00H
	01H		00H
CRC CHECK Low	9EH	CRC CHECK Low	B8H
CRC CHECK High	CAH	CRC CHECK High	44H

(2) Function code 06H: write into the register

For example, write 50.00Hz in the inverter address 1000H.

RTU mode:

Format of inquiry information		Format of response information	
Address	01H	Address	01H
Function code	06H	Function code	06H
Register address	10H	Register address	10H
	00H		00H
Data contents	27H	Data contents	27H
	10H		10H
CRC CHECK Low	97H	CRC CHECK Low	97H
CRC CHECK High	36H	CRC CHECK High	36H

(3) Command code: 08H communication loop test

This command is used to test whether the communication between the master control equipment and the inverter is normal. The frequency converter will return the received data to the main control equipment.

RTU mode

Format of inquiry information		Format of response information	
Address	01H	Address	01H
Function code	08H	Function code	08H
Contents	01H	Contents	01H
	02H		02H
	03H		03H
	04H		04H
CRC CHECK Low	41H	CRC CHECK Low	41H
CRC CHECK High	04H	CRC CHECK High	04H

(4) Parity code

RTU mode: double byte hexadecimal number.

The CRC domain is two bytes, containing 16-bit binary values. It is added to the message after calculation by the sender. The high byte of CRC is the last byte of the sending message. The receiving device recalculates the CRC of the received message and compares it with the value in the received CRC domain. If the two values are different, the received message has an error, discards the message frame, and does not respond to it. The next frame data will be received.

### Appendix B-3-3. Communication protocol parameter address

(1) The communication address of the function code parameter is shown in the table below. The high position is the group number and the low position is the parameter serial number.

Parameter group	Power off memory address	Power off no memory address
P0~PF	0x0000~0x0FFF	0x3000~0x3FFF
A0~AF	0xA000~0xAFFF	0x4000~0x4FFF
U0	0x7000~0x70xx	

- When reading function code data through the communication

For group P and group A function code data, the upper 16 bits of the communication address are the group number, and the lower 16 bits are the serial number of the function code in the function group.

For example, P0-16 function parameter, communication address is 0x0010, 00 represents the function parameter of group P0, and 10 represents the hexadecimal data format of function code 16 in function group.

A0-15 function parameter, communication address is 0xA00F, A0 represents A0 group function parameter, 0F represents hexadecimal data format of function code in function group serial number 15.

- When writing function code data through the communication

For group P function code data, the upper 16 bits of its communication address are divided into 0x0000 ~ 0x0FFF or 0x3000 ~ 0x3FFF according to whether it is written into EPPROM. The lower 16 bits are directly the serial number of the function code in the function group, for example:

Write function parameters P0-16:

When it is not necessary to write EPPROM, its communication address is 0x0010;

When the EPPROM needs to be written, its communication address is 0x3010;

For group A function code data, its communication address high 16 bits can be divided into 0xA000 ~ 0x0FFF or 0x4000 ~ 0x4FFF according to whether it is written into EPPROM. The lower 16 bits are the serial number of the function code in the function group, for example:

Write function parameter A0-15:

When EPPROM is not needed, its communication address is 0xA00F;

When the EPPROM needs to be written, its communication address is 0x400F.

(2) Non function code

Definition	Modbus address	Function	Note
Communication setting	1000H	Communication frequency	Write
Control command	1100H	1: Forward running 2: Reverse operation 3: Forward jog 4: Reverse jog 5: Deceleration stop 6: Free stop 7: Fault reset	Write
Digital output terminal control	1101H	bit0: Y1 output control bit1: Y2 output control bit2: reserved bit3: RELAY1 output control bit4: RELAY2 output control	Write
Analog output AO	1103H	0~7FFF represents 0%~100%	Write
Operation status	1200H	1: forward run	Read

Definition	Modbus address	Function	Note
		2: reverse run 3: stop	
VFD fault	1210H	0000H: None 0001H: acceleration over current 0002H: deceleration over current 0003H: constant speed over current 0004H: acceleration overvoltage 0005H: deceleration overvoltage 0006H: constant speed over voltage 0007H: buffer resistance overload fault 0008H: under voltage fault 0009H: inverter overload 000AH: motor overload 000BH: input phase missing 000CH: output phase missing 000DH: radiator overheating 000EH: contactor fault 000FH: current detection fault 0010H: motor tuning fault 0011H: code disk failure 0012H: motor short circuit to ground fault 0014H: wave by wave current limiting fault 0015H: pole position detection failed 0016H: UVW signal feedback error 0017H: brake resistance short circuit 001AH: SVC stall fault 002BH: external fault 002CH: Communication (timeout) failure 002DH: EEPROM read / write failure 002EH: run time arrived 002FH: power on time arrived 0030H: user defined fault 1 0031H: user defined fault 2 0032H: PID feedback lost during operation 0033H: switch motor during operation 0034H: large speed deviation 0035H: Motor overspeed 0036H: Motor overtemperature	Read

When the frequency is set by communication (P0-02=2),

---

$$Frequency (Hz) = \frac{Data \times P0 - 13}{10000},$$

Data can be register or value, user can calculate the Data value according to the above formula when the frequency is set by communication.

If there is a user password: after writing the correct password, read it within 30s, otherwise it will need to be written again.

# XINJE



**WUXI XINJE ELECTRIC CO., LTD.**

No.816, Jianzhu West Road, Binhu District,  
Wuxi City, Jiangsu Province, China  
214072

Tel: 400-885-0136

Fax: (510) 85111290

[www.xinje.com](http://www.xinje.com)