

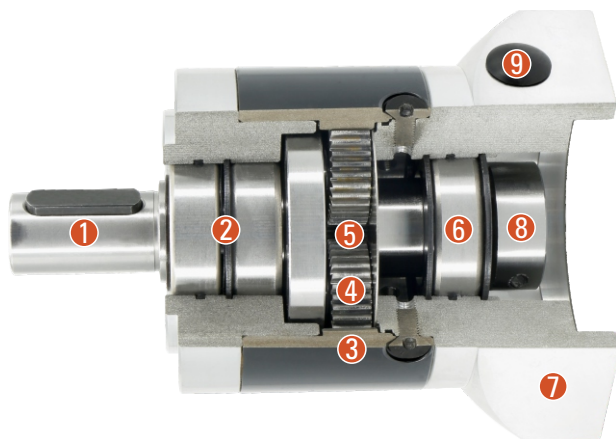

PLANETARY GEAR BOX

ZDE/ZDF/ZDWE/ZDWF/ZDS系列
高精度行星减速机

剖视图 Sectional Drawing



- ① 输出轴 Output shaft
- ② 输出轴轴承 Bearing for the output shaft
- ③ 内齿轮 Internal gear
- ④ 行星轮 Planetary gear
- ⑤ 太阳轮 Sunwheel
- ⑥ 太阳轮轴承 Bearing for the sunwheel
- ⑦ 适配电机法兰 Appropriate motor flange
- ⑧ 精密装夹系统 Precision clamping system
- ⑨ 装配孔 Mounting hole

系列号、机型标识说明 Type And Model Number

ZD系列减速机 ZD Series Gear Head				伺服电机 Servo Motor		
80	ZDE	20	()	(S)	-750	T1
①	②	③	④	⑤	⑥	⑦
① 减速机机座号:80				Gear head frame size:80		
② 减速机系列代号:				Gear head series code:		
ZDE:圆形安装法兰系列				ZDE:Round mounting flange series		
ZDWE:直角输入圆形安装法兰系列				ZDWE:Right angle input round mounting flange series		
ZDF:方形安装法兰系列				ZDF:Square mounting flange series		
ZDWF:直角输入方形安装法兰系列				ZDWF:Right angle input square mounting flange series		
ZDS:高刚性系列				ZDS:High stiffness series		
③ 减速比:				Gear Ratio:		
单级3,4,5,8,10;				Single Stage 3,4,5,8,10;		
两级9,12,15,16,20,25,32,40,64;				Two Stage 9,12,15,16,20,25,32,40,64;		
三级60,80,100,120,160,200,256,320,516;				Three Stage 60,80,100,120,160,200,256,320,516;		
④ 精度 Amount of backlash				机座号 Reducer Type No.		
输出轴负荷量为容许输出扭矩的±3%时的值				级数 Stage		
Precision (The load of output shaft is ±3% of allowable output torque)				标准型(省略) Standard Type		
				40ZDE/F		
				60ZDE/F		
				80ZDE/F		
				120ZDE/F		
				160ZDE/F		
				115ZDS		
				142ZDS		
				190ZDS		
				60ZDW/F		
				80ZDW/F		
				120ZDW/F		
				160ZDW/F		
⑤ 输入轴型式				Input shaft type		
S:整体锁紧(省略)(无论马达是否有键槽都可使用)				S:Over locking (Omission) (Regardless whether the motor with keyway can use it.)		
S1:带锁紧环锁紧(无论马达是否有键槽都可使用)				S1:Locking with locking ring (Regardless whether the motor with keyway can use it.)		
S2:带键槽锁紧(输入轴带键)				S2:Locking with keyway (Input shaft with key)		
K:带键槽				K:With keyway		
A:其他适配器(请与本公司联系)				A:Other type (Please contact with us)		
⑥ 适用伺服马达功率(W)				Applicable servo motor power (W)		
⑦ 输入法兰与伺服电机对应尺寸表(P15)				Input flange and servo motor matching table (P15)		

ZDE/ZDF系列精密行星减速机

ZDE/ZDF SERIES PRECISION PLANETARY GEAR MOTOR

产品图 Product Graph

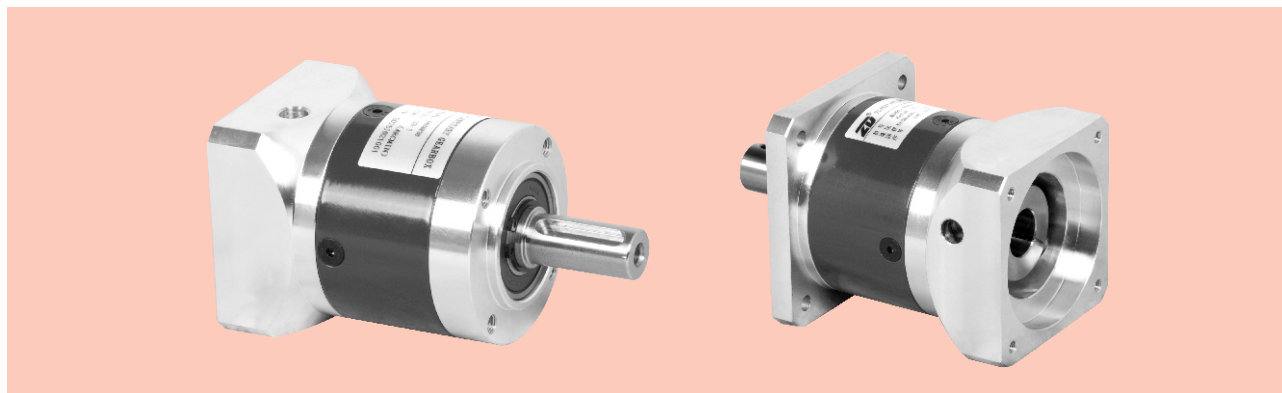

技术资料 Technical Data

产品型号 Product type		40	60	80	120	160	减速比 Reduction ratio	级数 Number of stage
额定输出扭矩 Rated output torque	N.M	4.5	12	40	80	400	3	1
		6	16	50	110	450	4	
		6	16	50	110	450	5	
		5	15	45	100	400	8	
		4	12	40	80	305	10	
		/	40	100	210	/	9	2
		16.5	40	100	210	700	12	
		16.5	40	100	210	700	15	
		20	44	120	260	800	16	
		20	44	120	260	800	20	
		18	40	110	230	700	25	
		20	44	120	260	800	32	
		18	40	110	230	700	40	
		7.5	18	45	100	400	64	
		16.5	40	100	210	/	60	
		20	44	120	260	/	80	
		20	44	120	260	/	100	
		16.5	40	100	210	/	120	
		20	44	120	260	/	160	
18	40	110	230	/	200			
20	44	120	260	/	256			
18	40	110	230	/	320			
7.5	18	45	100	/	512			
寿命 Life	小时 Hour	20,000						
瞬间急停扭矩 Instant stop torque	N.M	2倍于额定输出扭矩 Two times of rated output torque						
产品型号 Product type		40	60	80	120	160	单位 Unit	级数 Number of stage
最大径向力 Max radial torque		160	450	900	2100	6000	N	
最大轴向力 Max axial torque		80	225	450	1050	3000	N	
满载效率 Full load efficiency		96					%	1
		94						2
		90						3
重量 Weight		0.4	0.9	2.1	6	18	Kg	1
		0.5	1.1	2.6	8	22		2
		0.6	1.3	3.1	9.5	/		3
工作温度 Operating temperature		-25~+90					°C	
保护等级 IP		IP54						
润滑方式 Lubrication type		终身润滑 Lifetime lubrication						
安装方式 Mounting type		任意 Any						

最大径向力与最大轴向力,输出100RPM时,作用于输出轴中心位置(L/2)处。

The max radial and axial torque work in the location of the center of output shaft when the out speed is 100RPM.

ZDE/ZDF系列精密行星减速机

ZDE/ZDF SERIES PRECISION PLANETARY GEAR MOTOR

技术资料 Technical Data

产品型号 Product type		40	60	80	120	160	减速比 Reduction ratio
转动惯量 Moment of inertia	Kgcm ²	0.031	0.135	0.77	2.63	12.14	3
		0.022	0.093	0.52	1.79	7.78	4
		0.019	0.078	0.45	1.53	6.07	5
		0.017	0.065	0.39	1.32	4.63	8
		0.015	0.054	0.34	1.14	3.52	10
		/	0.131	0.74	2.62	/	9
		0.022	0.088	0.50	2.56	7.47	12
		0.019	0.077	0.44	1.79	6.65	15
		0.022	0.088	0.50	1.75	7.47	16
		0.019	0.075	0.44	1.50	6.65	20
		0.019	0.075	0.44	1.49	5.81	25
		0.017	0.064	0.39	1.30	4.50	32
		0.016	0.064	0.39	1.30	4.50	40
		0.016	0.064	0.39	1.30	4.50	64
		0.019	0.075	0.50	1.50	/	60
		0.019	0.075	0.50	1.50	/	80
		0.019	0.075	0.44	1.49	/	100
		0.016	0.064	0.39	1.30	/	120
0.016	0.064	0.39	1.30	/	160		
0.016	0.064	0.39	1.30	/	200		
0.016	0.064	0.39	1.30	/	256		
0.016	0.064	0.39	1.30	/	320		
0.016	0.064	0.39	1.30	/	512		

产品型号 Product type		40	60	80	120	160	级数 Number of stage
回程间隙 Backlash	arcmin 弧分	< 12	< 8	< 8	< 8	< 8	1
		< 15	< 12	< 12	< 12	< 12	2
		< 18	< 15	< 15	< 15	/	3

产品型号 Product type		40	60	80	120	160	
抗扭刚性 Torsional stiffness	N.M/arcmin	0.7	1.8	4.5	12	38	
噪声 Noise	dB(A)	55	58	60	65	70	
最高输入转速 Max input speed	min ⁻¹	4500	4500	4500	4500	4500	
推荐输入转速 Recommnd input speed	min ⁻¹	3000	3000	3000	3000	3000	

- 转动惯量与输入轴有关。The moment of inertia is related with input shaft.
- 噪声检测标准，距离1m，在输入转速3000转/分空载时测得。Noise test standard pressure level, distance 1m, measured on idle running with an input speed of 3000rpm.

ZDE系列精密行星减速机

ZDE SERIES PRECISION PLANETARY GEAR MOTOR

机械参数 Dimensions

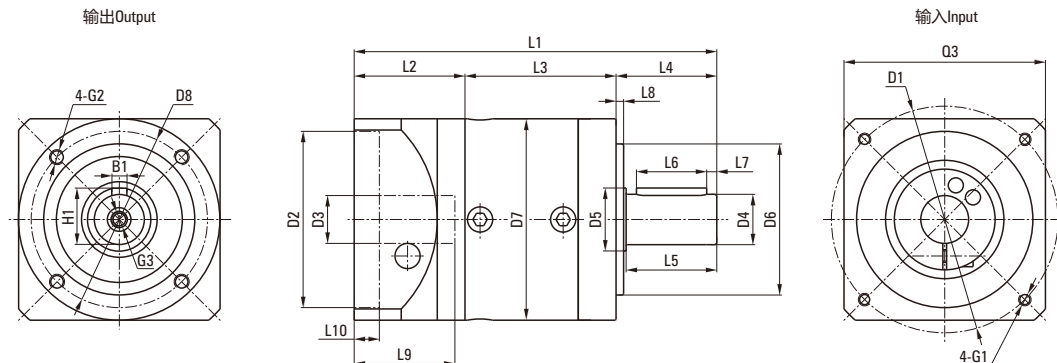

单位 Unit: mm

产品型号 Product type	40ZDE			60ZDE			80ZDE			120ZDE			160ZDE	
级数 Number of stage	1	2	3	1	2	3	1	2	3	1	2	3	1	2
L1箱体总长 L1 overall length	93.5	106.5	119	113.5	126.5	139.5	144	162	179.5	195.2	223	250.5	291	340.5
L3箱体长度 L3 body length	39	52	64.5	46.5	59.5	72.5	60	78	95.5	73.7	101.5	129	104	153.5
输出端 Output														
L4出轴长度 L4 output shaft length	26			35			40			55			87	
L5出轴长至轴肩 L5 output length to the shaft shoulder	23			30.5			36			50			80	
L6键长度 L6 key length	16			25			28			40			70	
L7键至轴末端长 L7 key length to the shaft end	2.5			2.5			4			5			5	
L8定位凸台长度 L8 spigot length	2			3			3			4			5	
D4出轴直径 D4 output shaft diameter	Φ10h7			Φ14h7			Φ20h7			Φ25h7			Φ40h7	
D5轴肩直径 D5 shaft shoulder diameter	Φ12			Φ17			Φ25			Φ35			Φ55	
D6定位凸台直径 D6 spigot diameter	Φ26h7			Φ40h7			Φ60h7			Φ80h7			Φ130h7	
D7箱体直径 D7 body diameter	Φ40			Φ60			Φ80			Φ115			Φ160	
D8安装孔分布圆 D8 hole circle	Φ34			Φ52			Φ70			Φ100			Φ145	
B1键宽 B1 key width	3			5			6			8			12	
H1键高 H1 key height	11.2			16			22.5			28			43	
G2安装螺纹孔 G2 mounting screw hole	M4X6			M5X8			M6X10			M10X16			M12X20	
G3中心螺纹孔 G3 center screw hole	M3X9			M5X12			M6X16			M10X22			M12X25	
输入端 Input														
L2输入法兰长度 L2 input flange length	28.5			32			44			66.5			99	
L9电机轴长度 L9 motor shaft length	26			30			40			58			79	
L10定位凸台深 L10 spigot depth	6			10			10			10			10	
D1安装孔分布圆 D1 mounting hole distribution circle	Φ46			Φ70			Φ90			Φ145			Φ200	
D2定位凸台直径 D2 spigot diameter	Φ30G7			Φ50G7			Φ70G7			Φ110G7			Φ114.3G7	
D3输入轴轴径 D3 input shaft diameter	≤Φ8G7			≤Φ14G7			≤Φ19G7			≤Φ24G7			≤Φ35G7	
G1安装螺纹孔x深度 G1 mounting threads x depth	M4X10			M5X12			M6X15			M8X22			M12X25	
Q3输入法兰 Q3 input flange	□40			□60			□80			□130			□175	

※输入端尺寸可根据电机尺寸制作。

※Input size made according to motor size.

ZDF系列精密行星减速机

ZDF SERIES PRECISION PLANETARY GEAR MOTOR

机械参数 Dimensions

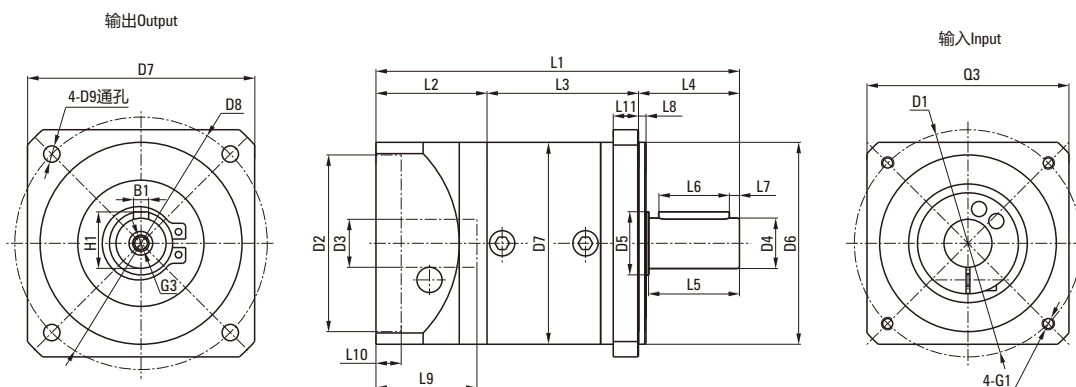

单位 Unit: mm

产品型号 Product type	40ZDF			60ZDF			80ZDF			120ZDF			160ZDF	
级数 Number of stage	1	2	3	1	2	3	1	2	3	1	2	3	1	2
L1箱体总长 L1 overall length	93.5	106.5	119	113.5	126.5	139.5	144	162	179.5	195.2	223	250.5	291	340.5
L3箱体长度 L3 body length	39	52	64.5	46.5	59.5	72.5	60	78	95.5	73.7	101.5	129	104	153.5
输出端 Output														
L4出轴长度 L4 output shaft length	26			35			40			55			87	
L5出轴长至轴肩 L5 output length to the shaft shoulder	23			30.5			36			50			80	
L6键长度 L6 key length	16			25			28			40			70	
L7键至轴末端长 L7 key length to the shaft end	2.5			2.5			4			5			5	
L8定位凸台长度 L8 spigot length	2			3			3			4			5	
L11输出法厚度 L11 output flange thickness	6			8			10			15			15	
D4出轴直径 D4 output shaft diameter	Φ10h7			Φ14h7			Φ20h7			Φ25h7			Φ40h7	
D5轴肩直径 D5 shaft shoulder diameter	Φ12			Φ17			Φ25			Φ35			Φ55	
D6定位凸台直径 D6 spigot diameter	Φ26h7			Φ50h7			Φ80h7			Φ110h7			Φ130h7	
D7输出法兰 D7 output flange	□45			□60			□90			□120			□160/□175	
D8安装孔分布圆 D8 hole circle	Φ50			Φ70			Φ100			Φ130			Φ185/Φ200	
D9法兰安装孔 D9 mounting hole	Φ3.5			Φ5.5			Φ6.5			Φ8.5			Φ11/Φ13.5	
B1键宽 B1 key width	3			5			6			8			12	
H1键高 H1 key height	11.2			16			22.5			28			43	
G3中心螺纹孔 G3 center screw hole	M3X9			M5X12			M6X16			M10X22			M12X25	
输入端 Input														
L2输入法兰长度 L2 input flange length	28.5			32			44			66.5			99	
L9电机轴长度 L9 motor shaft length	26			30			40			58			79	
L10定位凸台深 L10 spigot depth	6			10			10			10			10	
D1安装孔分布圆 D1 mounting hole distribution circle	Φ46			Φ70			Φ90			Φ145			Φ200	
D2定位凸台直径 D2 spigot diameter	Φ30G7			Φ50G7			Φ70G7			Φ110G7			Φ114.3G7	
D3输入轴轴径 D3 input shaft diameter	≤Φ8G7			≤Φ14G7			≤Φ19G7			≤Φ24G7			≤Φ35G7	
G1安装螺纹孔x深度 G1 mounting threads x depth	M4X10			M5X12			M6X15			M8X22			M12X25	
Q3输入法兰 Q3 input flange	□40			□60			□80			□130			□175	

※输入端尺寸可根据电机尺寸制作。

※Input size made according to motor size.

ZDWE/ZDWF系列精密行星减速机

ZDWE/ZDWF SERIES PRECISION PLANETARY GEAR MOTOR

产品图 Product Graph

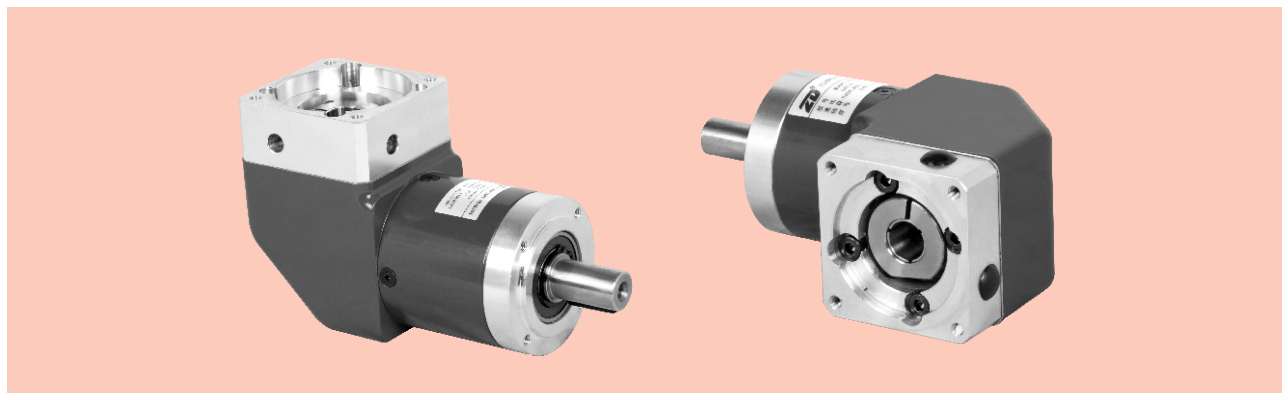

技术资料 Technical Data

产品型号 Product type		60	80	120	160	减速比 Reduction ratio	级数 Number of stage
额定输出扭矩 Rated output torque	N.M	12	40	80	400	3	1
		16	50	110	450	4	
		16	50	110	450	5	
		15	45	100	400	8	
		12	40	80	305	10	
		40	100	210	/	9	2
		40	100	210	700	12	
		40	100	210	700	15	
		44	120	260	800	16	
		44	120	260	800	20	
		40	110	230	700	25	3
		44	120	260	800	32	
		40	110	230	700	40	
		18	45	100	400	64	
		40	100	210	/	60	
		44	120	260	/	80	3
		44	120	260	/	100	
		40	100	210	/	120	
		44	120	260	/	160	
		40	110	230	/	200	
44	120	260	/	256	3		
40	110	230	/	320			
18	45	100	/	512			
寿命 Life	小时 Hour	20,000					
瞬间急停扭矩 Instant stop torque	N.M	2倍于额定输出扭矩 Two times of rated output torque					
产品型号 Product type		60	80	120	160	单位 Unit	级数 Number of stage
最大径向力 Max radial torque		450	900	2100	6000	N	
最大轴向力 Max axial torque		225	450	1050	3000	N	
满载效率 Full load efficiency		94				%	1
		92					2
		88					3
重量 Weight		1.7	4.4	12	36	Kg	1
		1.9	5	14	40		2
		2.1	5.5	16	/		3
工作温度 Operating temperature		-25~+90				°C	
保护等级 IP		IP54					
润滑方式 Lubrication type		终身润滑 Lifetime lubrication					
安装方式 Mounting type		任意 Any					

最大径向力与最大轴向力,输出100RPM时,作用于输出轴中心位置(L/2)处。

The max radial and axial torque work in the location of the center of output shaft when the out speed is 100RPM.

ZDWE/ZDWF系列精密行星减速机

ZDWE/ZDWF SERIES PRECISION PLANETARY GEAR MOTOR

技术资料 Technical Data

产品型号 Product type		60	80	120	160	减速比 Reduction ratio
转动惯量 Moment of inertia	Kgcm ²	0.246	1.189	5.75	24.5	3
		0.204	0.939	3.91	19.4	4
		0.189	0.869	3.35	17.5	5
		0.176	0.809	2.89	15.9	8
		0.152	0.730	2.54	15.5	10
		0.242	1.159	5.73	/	9
		0.199	0.919	3.83	/	12
		0.188	0.859	3.28	17.5	15
		0.199	0.919	3.83	19.4	16
		0.186	0.859	3.28	17.5	20
		0.186	0.859	3.26	17.5	25
		0.175	0.809	2.84	15.9	32
		0.175	0.809	2.84	15.9	40
		0.175	0.809	2.84	15.9	64
		0.186	0.919	3.28	/	60
		0.186	0.919	3.28	/	80
		0.186	0.859	3.26	/	100
		0.175	0.809	2.84	/	120
		0.175	0.809	2.84	/	160
0.175	0.809	2.84	/	200		
0.175	0.809	2.84	/	256		
0.175	0.809	2.84	/	320		
0.175	0.809	2.84	/	512		

产品型号 Product type		60	80	120	160	级数 Number of stage
回程间隙 Backlash	arcmin 弧分	< 30	< 25	< 25	< 25	1
		< 35	< 30	< 30	< 30	2
		< 40	< 35	< 35	/	3
抗扭刚性 Torsional stiffness	N.M/arcmin	1.5	4.5	10	38	1
		2.5	6.5	13	43	2
		2.5	6.3	12	/	3
噪声 Noise	dB(A)	65	68	70	70	
最高输入转速 Max input speed	min ⁻¹	4500	4500	4500	4500	
推荐输入转速 Recommnd input speed	min ⁻¹	3000	3000	3000	3000	

1. 转动惯量与输入轴有关。The moment of inertia is related with input shaft.

2. 噪声检测标准，距离1m，在输入转速3000转/分空载时测得。Noise test standard pressure level, distance 1m, measured on idle running with an input speed of 3000rpm.

ZDWE系列精密行星减速机

ZDWE SERIES PRECISION PLANETARY GEAR MOTOR

机械参数 Dimensions

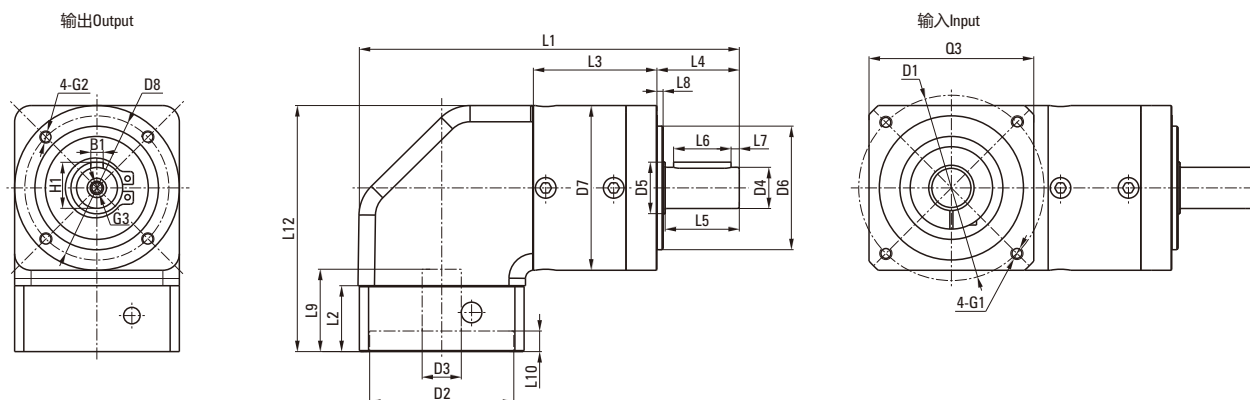

单位 Unit: mm

产品型号 Product type	60ZDWE			80ZDWE			120ZDWE			160ZDWE	
级数 Number of stage	1	2	3	1	2	3	1	2	3	1	2
L1箱体总长 L1 overall length	150	163	176	184.5	202.5	220	249.2	277	304.5	368	417.5
L3箱体长度 L3 body length	46.5	59.5	72.5	60	78	95.5	73.7	101.5	129	129	178.5
L12总高 L12 overall heights	93			119.5			167.5			229	
输出端 Output											
L4出轴长度 L4 output shaft length	35			40			55			87	
L5出轴长至轴肩 L5 output length to the shaft shoulder	30.5			36			50			80	
L6键长度 L6 key length	25			28			40			70	
L7键至轴末端长 L7 key length to the shaft end	2.5			4			5			5	
L8定位凸台长度 L8 spigot length	3			3			4			5	
D4出轴直径 D4 output shaft diameter	Φ14h7			Φ20h7			Φ25h7			Φ40h7	
D5轴肩直径 D5 shaft shoulder diameter	Φ17			Φ25			Φ35			Φ55	
D6定位凸台直径 D6 spigot diameter	Φ40h7			Φ60h7			Φ80h7			Φ130h7	
D7箱体直径 D7 body diameter	Φ60			Φ80			Φ115			Φ160	
D8安装孔分布圆 D8 hole circle	Φ52			Φ70			Φ100			Φ145	
B1键宽 B1 key width	5			6			8			12	
H1键高 H1 key height	16			22.5			28			43	
G2安装螺纹孔x深度 G2 mounting thread x depth	M5X8			M6X10			M10X16			M12X20	
G3中心螺纹孔 G3 center screw hole	M5X12			M6X16			M10X22			M12X25	
输入端 Input											
L2输入法兰长度 L2 input flange length	20			32			38			66	
L9电机轴长度 L9 motor shaft length	30			40			58			81	
L10定位凸台深 L10 spigot depth	5			10			10			10	
D1安装孔分布圆 D1 mounting hole distribution circle	Φ70			Φ90			Φ145			Φ200	
D2定位凸台直径 D2 spigot diameter	Φ50G7			Φ70G7			Φ110G7			Φ114.3G7	
D3输入轴轴径 D3 input shaft diameter	≤Φ14G7			≤Φ19G7			≤Φ24G7			≤Φ35G7	
G1安装螺纹孔x深度 G1 mounting threads x depth	M5X12			M6X15			M8X22			M12X25	
Q3输入法兰 Q3 input flange	□60			□80			□130			□175	

※输入端尺寸可根据电机尺寸制作。
 ※Input size made according to motor size.

ZDWF系列精密行星减速机

ZDWF SERIES PRECISION PLANETARY GEAR MOTOR

机械参数 Dimensions

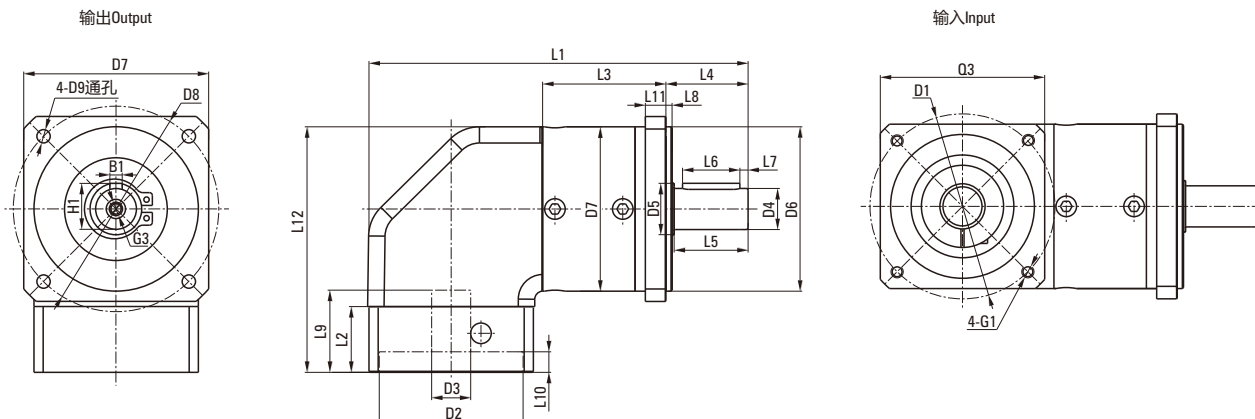

单位 Unit: mm

产品型号 Product type	60ZDWF			80ZDWF			120ZDWF			160ZDWF	
级数 Number of stage	1	2	3	1	2	3	1	2	3	1	2
L1箱体总长 L1 overall length	150	163	176	184.5	202.5	220	249.2	277	304.5	368	417.5
L3箱体长度 L3 body length	46.5	59.5	72.5	60	78	95.5	73.7	101.5	129	129	178.5
L12总高 L12 overall heights	93			119.5			167.5			229	
输出端 Output											
L4出轴长度 L4 output shaft length	35			40			55			87	
L5出轴长至轴肩 L5 output length to the shaft shoulder	30.5			36			50			80	
L6键长度 L6 key length	25			28			40			70	
L7键至轴末端长 L7 key length to the shaft end	2.5			4			5			5	
L8定位凸台长度 L8 spigot length	3			3			4			5	
L11法兰厚度 L11 flange thickness	8			10			15			5	
D4出轴直径 D4 output shaft diameter	Φ14h7			Φ20h7			Φ25h7			Φ40h7	
D5轴肩直径 D5 shaft shoulder diameter	Φ17			Φ25			Φ35			Φ55	
D6定位凸台直径 D6 spigot diameter	Φ50h7			Φ80h7			Φ110h7			Φ130h7	
D7箱体直径 D7 body diameter	□60			□90			□120			□160/□175	
D8安装孔分布圆 D8 hole circle	Φ70			Φ100			Φ130			Φ185/Φ200	
D9法兰安装孔 D9 mounting bore	Φ5.5			Φ6.5			Φ8.5			Φ11/Φ13.5	
B1键宽 B1 key width	5			6			8			12	
H1键高 H1 key height	16			22.5			28			43	
G3中心螺纹孔 G3 center screw hole	M5X12			M6X16			M10X22			M12X25	
输入端 Input											
L2输入法兰长度 L2 input flange length	20			32			38			66	
L9电机轴长度 L9 motor shaft length	30			40			58			81	
L10定位凸台深 L10 spigot depth	5			10			10			10	
D1安装孔分布圆 D1 mounting hole distribution circle	Φ70			Φ90			Φ145			Φ200	
D2定位凸台直径 D2 spigot diameter	Φ50G7			Φ70G7			Φ110G7			Φ114.3G7	
D3输入轴轴径 D3 input shaft diameter	≤Φ14G7			≤Φ19G7			≤Φ24G7			≤Φ35G7	
G1安装螺纹孔x深度 G1 mounting threads x depth	M5X12			M6X15			M8X22			M12X25	
Q3输入法兰 Q3 input flange	□60			□80			□130			□175	

※输入端尺寸可根据电机尺寸制作。

※Input size made according to motor size.

ZDS系列精密行星减速机

ZDS SERIES PRECISION PLANETARY GEAR MOTOR

产品图 Product Graph

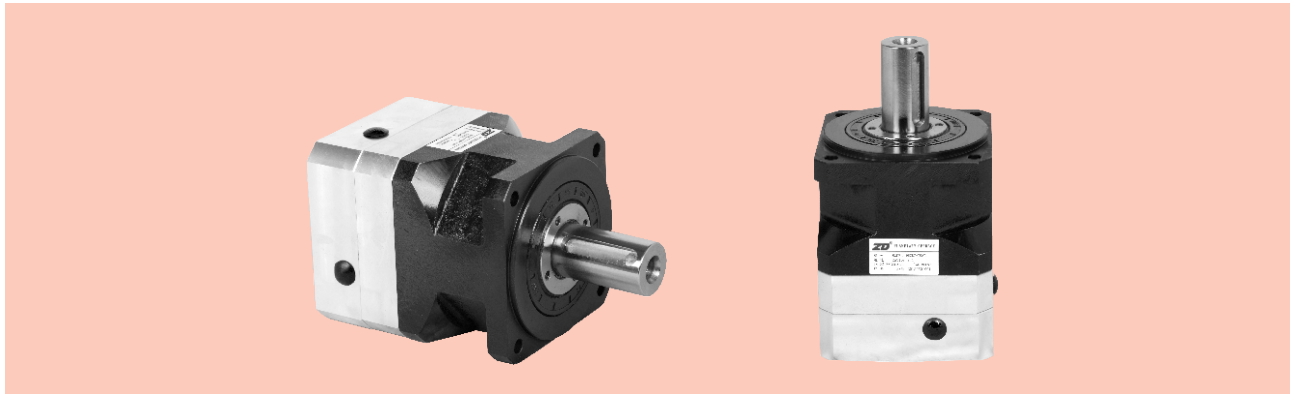

技术资料 Technical Data

产品型号 Product type		115	142	190	减速比 Reduction ratio	级数 Number of stage		
额定输出扭矩 Rated output torque	N.M	150	400	1000	3	1		
		200	560	1200	4			
		210	700	1600	5			
		148	450	1000	8			
				125	305	630	10	2
				210	780	1500	12	
				210	780	1500	15	
				260	910	1800	16	
				260	910	1800	20	
				210	780	1800	25	
				260	910	1800	32	
				210	780	1800	40	
				148	450	1000	64	
				125	305	630	100	
寿命 Life	小时 Hour	20,000						
瞬间急停扭矩 Instant stop torque	N.M	2倍于额定输出扭矩 Two times of rated output torque						

产品型号 Product type	115	142	190	单位 Unit	级数 Number of stage
最大径向力 Max radial torque	4300	8200	12000	N	
最大轴向力 Max axial torque	12000	19000	28000	N	
满载效率 Full load efficiency	96			%	1
	94				2
重量 Weight	9	15.4	33.5	Kg	1
	11.6	18.5	45		2
工作温度 Operating temperature	-25~+90			°C	
保护等级 IP	IP65				
润滑方式 Lubrication type	终身润滑 Lifetime lubrication				
安装方式 Mounting type	任意 Any				

最大径向力与最大轴向力,输出100RPM时,作用于输出轴中心位置(L/2)处。

The max radial and axial torque work in the location of the center of output shaft when the out speed is 100RPM.

ZDS系列精密行星减速机

ZDS SERIES PRECISION PLANETARY GEAR MOTOR

技术资料 Technical Data

产品型号 Product type		115	142	190	减速比 Reduction ratio
转动惯量 Moment of inertia	kgcm ²	2.10	12.14	47.52	3
		1.51	7.78	29.69	4
		1.22	6.07	23.18	5
		1.05	4.63	16.83	8
		1.00	4.25	15.32	10
		1.48	7.47	28.95	12
		1.41	6.65	22.71	15
		1.48	7.47	28.95	16
		1.41	6.65	22.71	20
		1.21	5.81	22.46	25
		1.46	6.36	16.65	32
		1.05	5.28	16.54	40
		1.05	4.50	16.45	64
		1.00	4.17	15.07	100

产品型号 Product type		115	142	190	级数 Number of stage
回程间隙 Backlash	arcmin	< 8	< 8	< 8	1
	弧分	< 12	< 12	< 12	2
抗扭刚性 Torsional stiffness	N.M/arcmin	20	44	130	1
		22	46	140	2
噪声 Noise	dB(A)	65	68	70	
最高输入转速 Max input speed	min ⁻¹	4500	4500	3000	
推荐输入转速 Recommnd input speed	min ⁻¹	3000	3000	2000	

1. 转动惯量与输入轴有关。The moment of inertia is related with input shaft.
2. 噪声检测标准，距离1m，在输入转速3000转/分空载时测得。Noise test standard pressure level, distance 1m, measured on idle running with an input speed of 3000rpm.

ZDS系列精密行星减速机

ZDS SERIES PRECISION PLANETARY GEAR MOTOR

机械参数 Dimensions

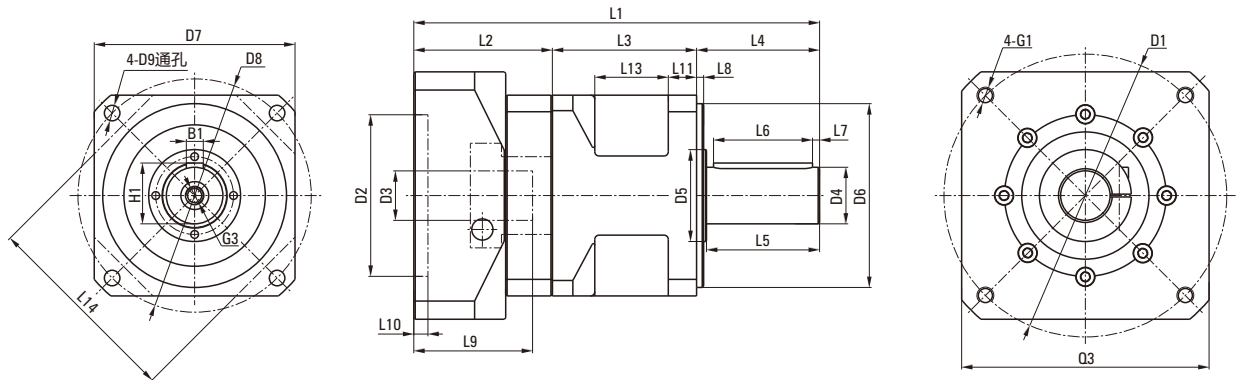

单位 Unit: mm

产品型号 Product type	115ZDS		142ZDS		190ZDS	
级数 Number of stage	1	2	1	2	1	2
L1箱体总长 L1 overall length	213	246.5	289	338.5	308.5	356
L3箱体长度 L3 body length	77.5	111	102	151.5	121.5	169
输出端 Output						
L4出轴长度 L4 output shaft length	64.5		87		90	
L5出轴长至轴肩 L5 output length to the shaft shoulder	58		80		82	
L6键长度 L6 key length	50		70		70	
L7键至轴末端长 L7 key length to the shaft end	4		5		6	
L8定位凸台长度 L8 spigot length	4		5		6	
L11输出法厚度 L11 output flange thickness	14		20		20	
D4出轴直径 D4 output shaft diameter	Φ32h7		Φ40h7		Φ55h7	
D5轴肩直径 D5 shaft shoulder diameter	Φ55		Φ65		Φ95	
D6定位凸台直径 D6 spigot diameter	Φ110h7		Φ130h7		Φ160h7	
D7箱体直径 D7 body diameter	□115		□142		□190	
D8安装孔分布圆 D8 flange hole circle	Φ130		Φ165		Φ215	
D9法兰安装孔 D9 mounting bore	Φ8.5		Φ11		Φ13.5	
B1键宽 B1 key width	10		12		16	
H1键高 H1 key height	35		43		59	
G3中心螺纹孔 G3 center screw hole	M12X25		M12X25		M16X35	
L13工艺槽宽度 L13 recess width	34	67.5	52	101.5	52	99.5
L14工艺槽 L14 recess	□115		□142		□190	
输入端 Input						
L2输入法兰长度 L2 input flange length	71		100		105	
L9电机轴长度 L9 motor shaft length	58		79		82	
L10定位凸台深 L10 spigot depth	10		10		8	
D1安装孔分布圆 D1 mounting hole distribution circle	Φ145		Φ200		Φ215	
D2定位凸台直径 D2 spigot diameter	Φ110G7		Φ114.3G7		Φ180G7	
D3输入轴轴径 D3 input shaft diameter	≤Φ24G7		≤Φ35G7		≤Φ42G7	
G1安装螺纹孔x深度 G1 mounting threads x depth	M8X22		M12X25		M12X25	
Q3输入法兰 Q3 input flange	□130		□175		□190	

※输入端尺寸可根据电机尺寸制作。
 ※Input size made according to motor size.

伺服电机对应尺寸表 SERVO MOTOR CORRESPONDING SIZE TABLE

减速器输入端 Gearbox Input

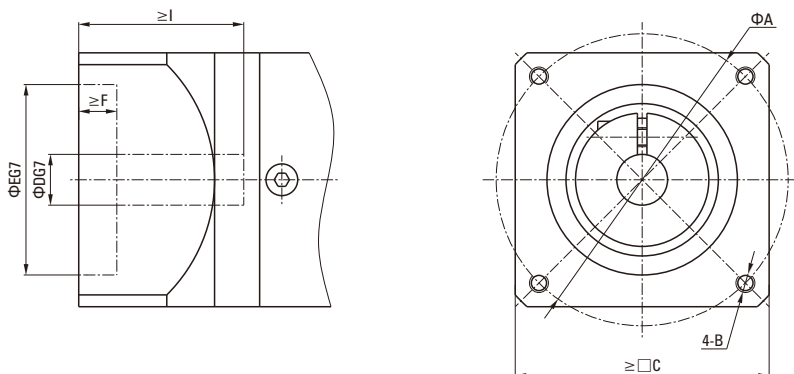

输入法兰与伺服电机对应尺寸表 Input Flange And Servo Motor Matching Table

电机功率 Motor Power (W)	电机尺寸 Motor Size	安装距 Installation Distance	螺纹孔 Threaded Hole	边框 Frame	孔径 Aperture	止口 Stop	止口深度 Stop Depth	轴伸 Shaft Extension
		A	B	C	D	E	F	I
50	T1	45	M3	38	8	30	3	25
	T2	46	M4	40	6	30	3	25
	T3	47	M4	40	8	30	3	25
	T4	48	M3	42	8	30	3	25
100	T1	45	M3	38	8	30	3	25
	T2	46	M4	40	8	30	3	25
	T3	46	M4	40	8	30	3	25
	T4	48	M3	42	8	30	3	25
200	T1	70	M4	60	11	50	3	30
	T2	70	M5	60	14	50	3	30
	T3	70	M5	60	14	50	3	30
400	T1	70	M4	60	14	50	3	30
	T2	70	M5	60	14	50	3	30
	T3	70	M5	60	14	50	3	30
750	T1	90	M5	80	19	70	3	35
	T2	90	M6	80	16	70	3	40
	T3	90	M6	80	19	70	3	40
	T4	100	M6	86	16	80	3	35
	T5	145	M8	130	19	110	6	58
	T6	100	M6	86	19	80	3	40
1000	T1	100	M6	90	19	80	3	55
	T2	115	M6	100	24	95	3	45
	T3	115	M8	100	24	95	5	45
	T4	145	M8	130	22	110	6	58
	T5	145	M8	130	22	110	6	70
	T6	115	M8	100	22	95	5	45
	T7	145	M8	130	24	110	3	55
1500	T1	115	M8	100	19	95	3	55
	T2	115	M6	100	24	95	3	45
	T3	115	M8	100	24	95	3	45
	T4	145	M8	130	22	110	6	58
	T5	145	M8	130	22	110	6	70
	T6	115	M8	100	22	95	5	45
	T7	145	M8	130	24	110	3	55

伺服电机对应尺寸表 SERVO MOTOR CORRESPONDING SIZE TABLE

■ 输入法兰与伺服电机对应尺寸表 Input Flange And Servo Motor Matching Table

电机功率 Motor Power (W)	电机尺寸 Motor Size	安装距 Installation Distance	螺纹孔 Threaded Hole	边框 Frame	孔径 Aperture	止口 Stop	止口深度 Stop Depth	轴伸 Shaft Extension
		A	B	C	D	E	F	I
2000	T1	115	M8	100	19	95	3	55
	T2	115	M6	100	24	95	3	45
	T3	115	M8	100	24	95	3	45
	T4	145	M8	130	22	110	6	58
	T5	200	M12	130	35	114.3	10	80
	T6	115	M8	100	22	95	5	45
2500	T1	115	M8	100	19	95	3	55
	T2	115	M6	100	24	95	3	45
3000	T1	130	M8	120	22	110	3	55
	T2	145	M8	130	28	110	6	65
	T4	145	M8	130	24	110	6	65
	T5	200	M12	175	35	114.3	10	80
	T7	200	M12	175	35	114.3	10	65
3500	T1	130	M8	120	22	110	3	55
	T2	145	M8	130	28	110	3	63
	T5	200	M12	175	35	114.3	10	80
4000	T1	145	M8	130	24	110	6	65
	T2	145	M8	130	28	110	6	65
	T5	200	M12	175	35	114.3	10	80
	T6	200	M12	175	42	114.3	10	113
4500	T1	145	M8	130	24	110	6	65
	T5	200	M12	175	35	114.3	10	80
	T6	200	M12	175	42	114.3	10	113
	T7	200	M12	175	35	114.3	10	65
5000	T1	145	M8	130	24	110	6	65
	T2	145	M8	130	28	110	6	65
	T5	200	M12	175	35	114.3	10	80
	T7	200	M12	175	35	114.3	10	65

注1)没有油封和尺寸不同时，安装带油封的马达有时需特别订货。

If an oil-seal is not present and the size is different, attachment of the oil-seal may correspond to special order, in some cases.

注2)马达轴为D形轴、锥形时需要特别订货。

If the motor shaft is of D-cut and taper type, it corresponds to a special order.

注3)标准外有时需要特别订货。欲知详情，请另外与本公司联系。

Out-of-standard may correspond to a special order in some cases, For details, contact us.

■ 安装马达的步骤 Assembly Procedure

客户自行安装伺服马达时，请按以下要领进行安装。伺服马达的尺寸多种多样，除指定的产品外，有些马达可能会无法连接法兰，因为，一定要使用您订货时指定的马达。

If a customer personally assembles the servo motor and reducer please use the following tip. The reducer flange to which the servo motor is attached has different dimensions based on the motor specified. Therefore, assembly may be impossible for some motor. Make sure the correct motor is specified before ordering the reducer.

1. 安装无键马达 Spec. In Case Of Assembling A Motor Without Key

- ①取下橡胶帽，转动输入轴，使螺栓头和紧定螺钉的孔吻合。并确认固定螺栓已松开。
Take off the rubber cap, turn the input shaft, and match the head of the bolt to the hole of the rubber cap. Make sure that the set bolt is loosened.
- ②将马达轴平稳地插入输入轴（请确保不受阻塞地顺畅的插入）。请充分注意不要让马达倾斜插入。
Gradually put the motor shaft into the input shaft (Ensure that it is smoothly put in without iam.)
Be careful not to be inserted with the motor tilted.
- ③将马达固定在减速机上，并按指定的扭矩将螺栓拧紧。参考表1
Attach the motor to the reducer and fasten the bolt with designated fastening torque. See Table 1.
- ④使用扭矩扳手等工具，按指定的扭矩将输入轴的固定螺栓拧紧。参考表2
Fasten the set bolt of the input shaft with designated fastening torque wrench, etc. See Table 2.
- ⑤盖上橡胶帽。安装到此结束。
Put on the rubber cap. It is the end of assembling.

● 表1 Table1

马达固定螺栓 Motor Combination Bolt	拧紧扭矩 Fastening Torque	
	(N-m)	(kgf-cm)
M3	1.0	10
M4	3.0	30
M5	5.8	60
M6	9.8	100
M8	19.6	200
M10	39.2	400
M12	68.6	700
M16	168	1650

● 表2 Table2

固定螺栓 Combination Bolt	拧紧扭矩 Fastening Torque	
	(N-m)	(kgf-cm)
M3	1.5	15
M4	3.5	35
M5	7.1	71
M6	12	120
M8	30	300
M10	60	612

带键槽式马达的键取下后，可以像上述无键马达一样安装。无需担心会滑动。

You can assemble the motor with keyway like above when take off the key. There is no risk of dislocation.

● ZDE/FWE/WF/S 系列示意图
ZDE/FWE/WF/S Series Schematic Diagram

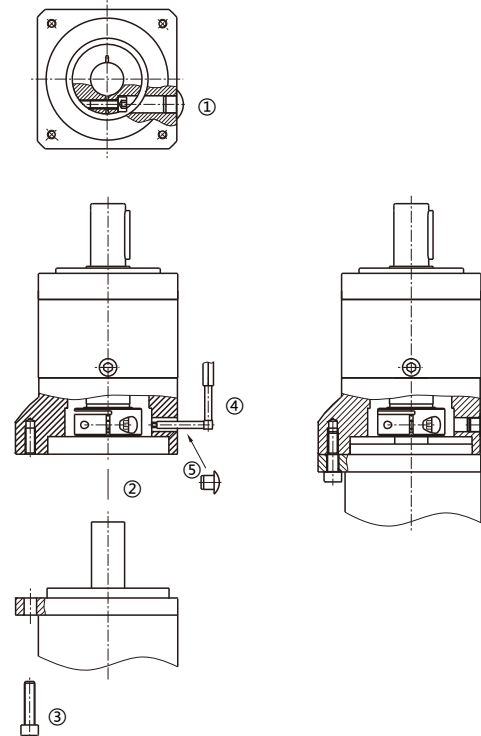

■ 减速机的安装 Reducer Assembly

将减速机安装在设备上时，请在确认安装面平坦且无毛刺等后，使用扭矩扳手等工具按指定的扭矩用螺栓将其固定。参考表4

Jointing with reducer In case of jointing a reducer with the device, make sure that the combining side is plane without inconsistency, and when assemble reducer outo equipment, ensuring assembly surface smooth and without burr. See Table 4.

● 表4 Table4

减速机固定螺栓 Reducer Combination Bolt	拧紧扭矩 Fastening Torque	
	(N·m)	(kgf·cm)
M5	5.8	60
M6	9.8	100
M8	19.6	200
M10	39.2	400
M12	68.6	700
M16	16.8	1650

■ 连接输出轴 Connection To The Output Shaft

注意事项 Cautions:

- 1、在输出轴上安装耦合器、滑轮等时，请勿在输出轴上施加过大的轴向负荷。
When assemble a coupling, pulley, etc. onto the output shaft, make sure that excessive axial load not be given to the output shaft.
- 2、请勿使用强力将轴敲入，以免使轴承或减速机内部受到损伤。
In case of strongly hitting the shaft with a hammer, the shaft inlet or the inside of the reducer may be damaged, therefore it shall be prohibited.
- 3、安装的耦合器等的轴和键槽如有较大松动，可能会导致设备烧毁，安装时请充分注意。 If the shaft or key of a coupling assembled is loosed, it may cause carbonization, so be careful when assembling.
- 4、安装耦合器等时，请使用固定螺栓来将键固定住。
For assembling of a coupling, fix the key with a set bolt.
- 5、连接时请充分调校轴心。 Please adjust shaft centre carefully in connecting.

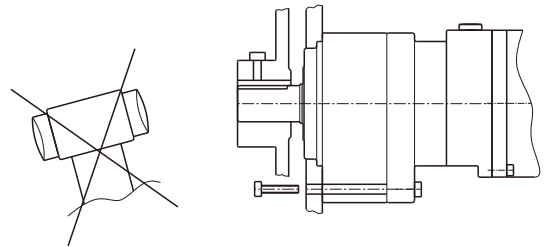

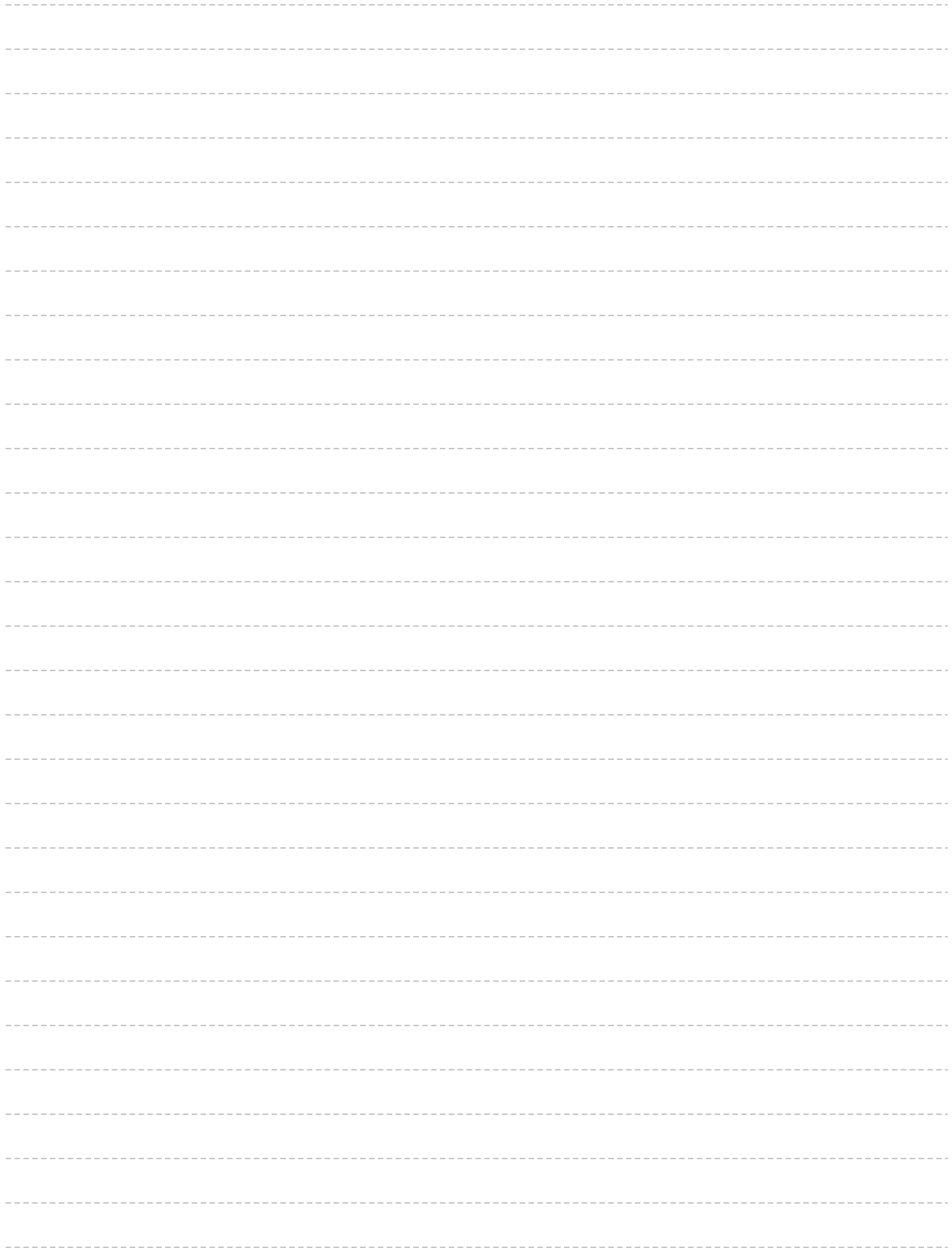

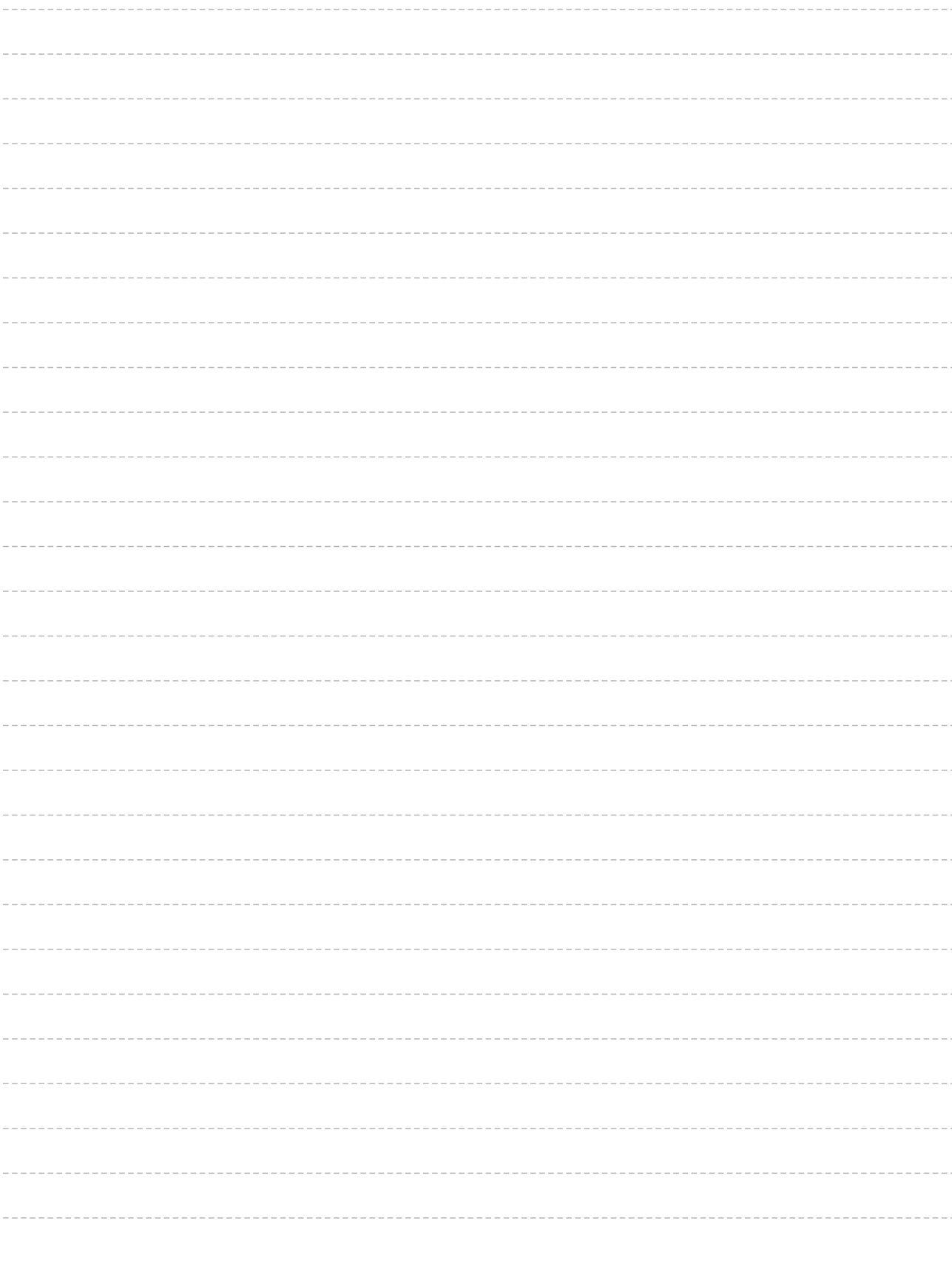

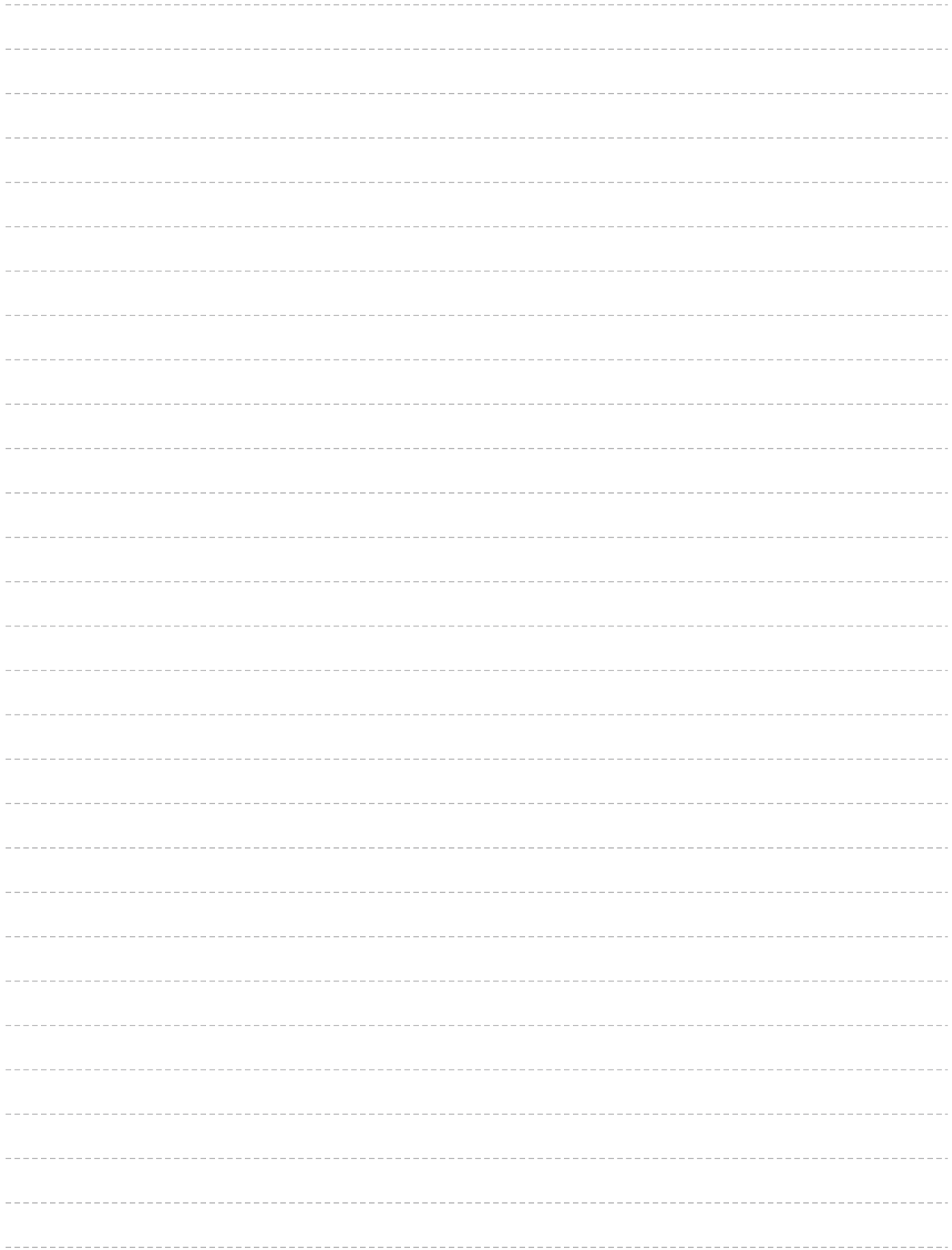

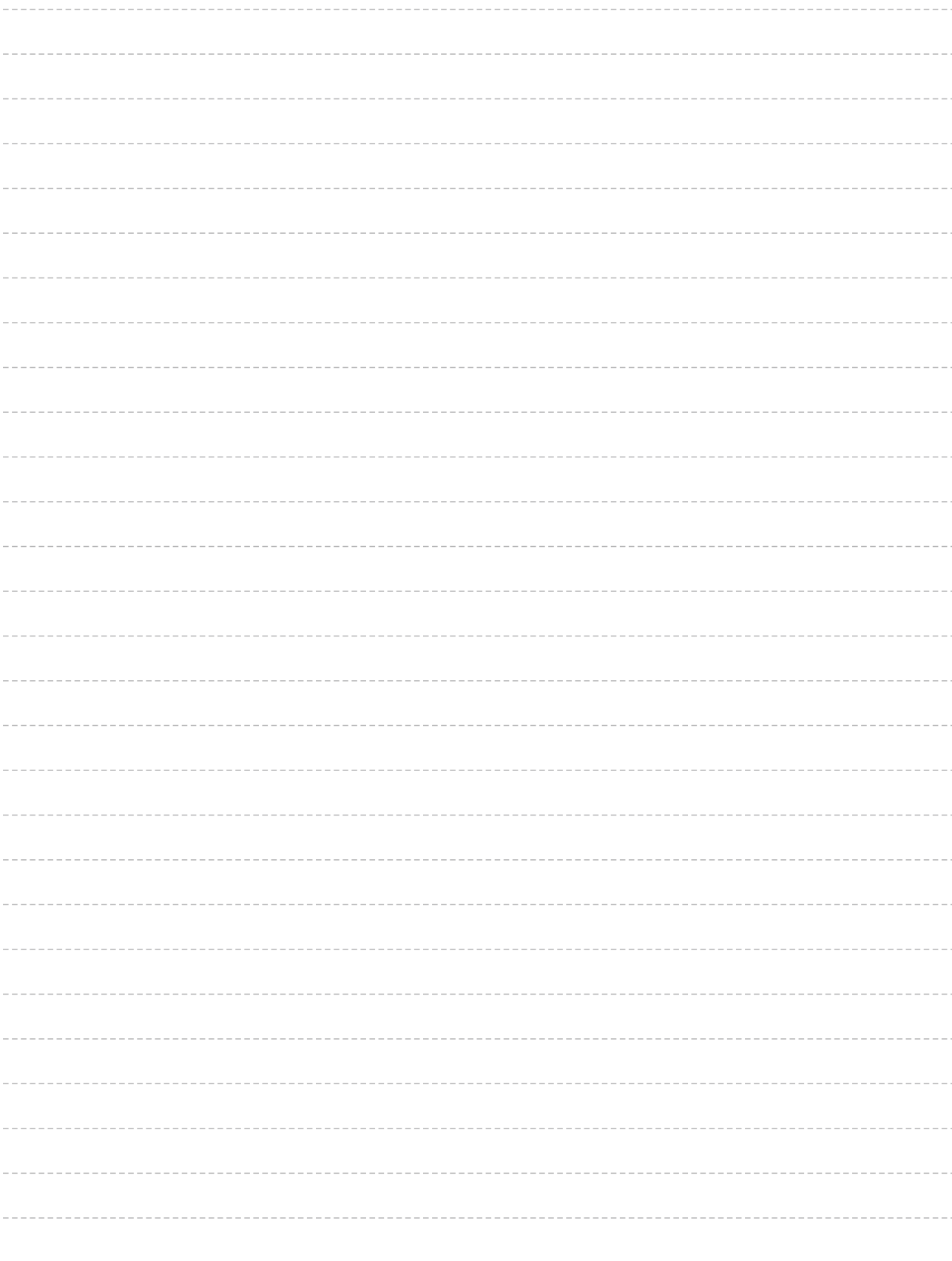

CATALOGUE



PLANETARY GEAR BOX
ZDR/ZDGF(S)系列
高精度行星减速机

ZD 中大力德



AC & DC RIGHT ANGLE GEAR MOTOR
交、直流直角轴减速机

ZD 中大力德



TRANSMISSION PLANETARY
传动行星减速机

ZD 中大力德



PLANETARY GEAR BOX
ZB/ZBR/ZE/HD系列
高精度行星减速机

ZD 中大力德



SMALL AC GEAR MOTOR
小型交流平行轴齿轮减速机

ZD 中大力德



DC BRUSHLESS GEAR MOTOR
直流无刷减速机

ZD 中大力德

PLANETARY GEAR BOX CATALOGUE

宁波中大力德智能传动股份有限公司
NINGBO ZHONGDA LEADER INTELLIGENT TRANSMISSION CO.,LTD.

地址：浙江省慈溪高新技术产业开发区新兴一路185号
Add : NO.185 1st Xinxing Road,New Industrial Zone, Cixi City, Zhejiang, China.

国内贸易服务：

电话：0574-63537377
传真：0574-63534879
E-mail: china@zd-motor.com

国际贸易服务：

International trade department:
Tel: 86-574-63530538 Fax: 86-574-63534879
E-mail: manager@zd-motor.com
E-mail: trade@zd-motor.com

更多详情，敬请浏览：
www.zd-motor.com